

# Water cooled central plant (all-variable)

---

## Design Envelope application guide

**File No:** 9.568UK

**Date:** APRIL 23, 2015

**Supersedes:** 9.568UK

**Date:** JANUARY 23, 2015

# DESIGN ENVELOPE APPLICATION GUIDES

**P**erformance improvements are among the top priorities of many building professionals today. Whether you are a developer, design consultant, engineer, contractor, facility manager or owner, chances are that you face increasing demands to not only reduce costs, but also deliver performance improvements. Public awareness on multiple levels - from the individual all the way through to government bodies - has grown to the point that energy conservation, carbon reduction, tenant comfort, and other health and environment-driven practices are key objectives for any prominent, sizeable building project.

To support and sustain this paradigm shift, Armstrong has developed a suite of advanced fluid flow and HVAC offerings that we call 'Design Envelope solutions'. Design Envelope solutions integrating intelligent demand-based control to deliver optimal performance and the lowest possible cost, both at commissioning and throughout their full operating life.

This document is one of our Design Envelope Application Guides, a set of booklets that discuss a broad range of real-world HVAC scenarios. In each scenario the use of Design Envelope technology can result in tremendous improvements in performance of your HVAC installation (compared to standard industry practice) and ultimately your building - technically, financially, and environmentally.

The intent of this Application Guide is to present HVAC System designers with an alternative to standard practices for design layout, configuration, and design calculations and help you leverage the full potential of Armstrong Design Envelope solutions. Each Application Guide addresses a specific system configuration for HVAC or data center applications. The system configurations cover heating and cooling scenarios, including circuit configurations ranging from all constant flow, to full variable flow and variable speed plant configurations. The Application Guides will present piping arrangements, valving requirements, de-coupler configurations, instrumentation locations, control system options, and the associated impact on first cost and life-cycle costs. The full series of application guides is available for download from Armstrong's website at [www.armstrongfluidtechnology.com](http://www.armstrongfluidtechnology.com)

# APPLICATION DIRECTORY

## HVAC

### COOLING

- 9.561UK - Water cooled chiller plant (all-variable)
- 9.562UK - Water cooled chiller plant (CP/VS)
- 9.563UK - Water cooled chiller plant with economiser
- 9.564UK - Ground source heat pump system (VP)

### HEATING

- 9.565UK - Condensing boiler plant (VP)
- 9.566UK - Condensing boiler plant (CP/VS)
- 9.567UK - Closed circuit heat pump system (VP)

### DISTRICT COOLING

**This guide covers: 9.568UK - Water cooled central plant (all-variable)**

- 9.569UK - Water cooled central plant (CP/VS)
- 9.570UK - Water cooled central plant (VP/VS)

## DATA CENTRES

### COOLING

- 9.571UK - Water cooled chiller plant with economiser (VP)
- 9.572UK - Water cooled chiller plant (all-variable)
- 9.573UK - Water cooled chiller plant (CP/VS)

VP = Variable primary flow

CP/VS = Constant primary flow / variable secondary flow

VP/VS = Variable primary flow / variable secondary flow

All-variable = All variable chiller plant, variable primary flow, variable secondary flow, variable condenser flow

The application discussed in this guide is a campus water-cooled chiller plant for HVAC applications, with between 3 & 12 chillers, and an all variable primary/secondary flow configuration. The corresponding building has 2-way control zone valves. Water-cooled chiller plants of this size and configuration typically start around 17,500 kW of installed cooling capacity.

**APPLICATION DETAILS**

Equipment	Water-cooled chillers	3-12
Use	HVAC	▪
Configuration	Var. primary flow	▪
	Var. secondary flow	▪
	Var. tower flow	▪

**DESIGN ENVELOPE BENEFITS SUMMARY**

Design Envelope benefit	Design Envelope savings over conventional plant
Lowest installed cost	34%
Lowest operating cost	20%
Lowest environmental cost/impact	Annual reduction in greenhouse gas emissions (tonnes): 742
Lowest project and operating risk	(See table on page 10)
<b>Total Design Envelope 1<sup>st</sup> year savings</b>	<b>26%</b>

FIG. 1  
DESIGN ENVELOPE PLANT LAYOUT.

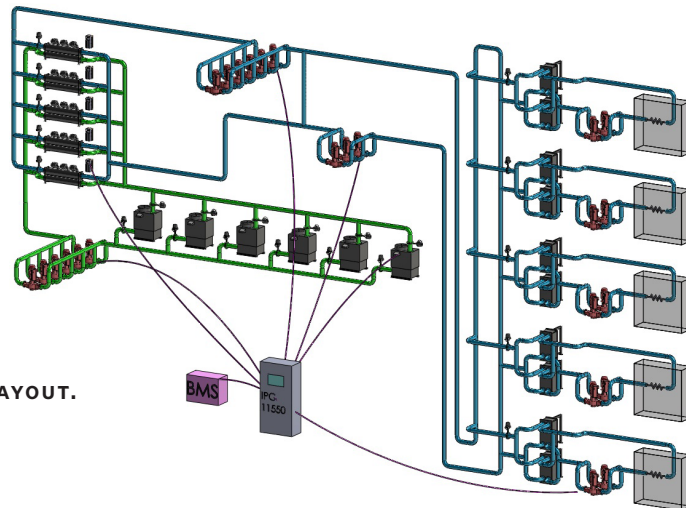
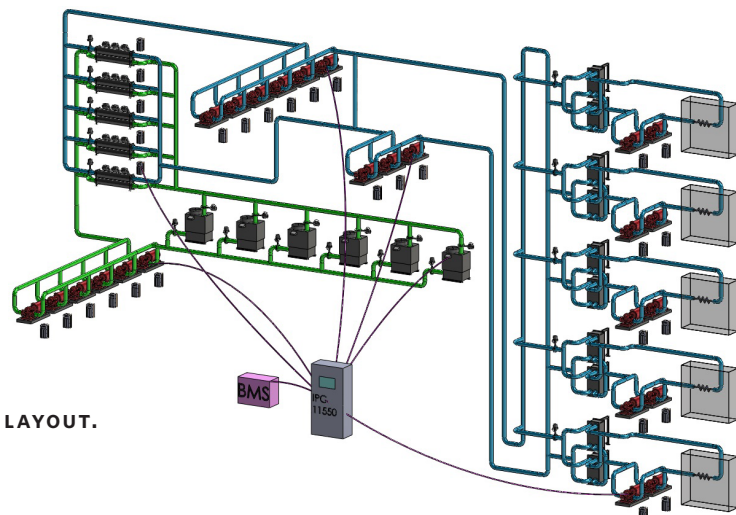

FIG. 2  
CONVENTIONAL PLANT LAYOUT.



**PLANT LAYOUT  
DESIGN ENVELOPE VS. CONVENTIONAL**

	Design Envelope plant	Conventional plant
Primary loop	Duty + 1-standby Design Envelope 4300 Vertical In Line pumps	Duty + 1-standby horizontal end suction pumps with remote variable frequency drive, poured concrete base, inertia base and springs, two line size flexible connectors, wall mounted VFD and power wiring.
Secondary loop	Duty + 1-standby Design Envelope 4300 Vertical In Line pumps	Duty + 1-standby horizontal end suction pumps with remote variable frequency drive, poured concrete base, inertia base and springs, two line size flexible connectors, wall mounted VFD and power wiring.
Tertiary loop	Duty + 1-standby Design Envelope pumps, duty + 1-standby heat exchanger	Duty + 1-standby horizontal end suction pumps with remote variable frequency drive, and duty + 1-standby heat exchanger, poured concrete base, inertia base and springs, two line size flexible connectors, wall mounted VFD and power wiring.
Condenser loop	Duty + 1-standby Design Envelope pumps for convenient flow balancing	Duty + 1-standby horizontal end suction pumps with remote variable frequency drive for flow balancing, poured concrete base, inertia base and springs, two line size flexible connectors, wall mounted VFD and power wiring.
Cooling towers	Single cell cooling towers where each fan motor is driven by a variable frequency drive	Single cell cooling towers where each fan motor is driven by a variable frequency drive

The plant configuration that best leverages the advantages of Design Envelope technology is a variable primary with a variable secondary, as the campus loop distribution circuit is best controlled with secondary pumps. This includes chilled water pumps on a common header, with multiple variable flow cooling towers on a common header, plus their corresponding Design Envelope 4300 condenser water pumps that complete the hydronic circuit.

The building loop includes multiple Design Envelope 4300 secondary pumps (there may be multiple secondary distribution pumps in actual installations for highly complex systems, or different pump quantities up to the discretion of the design engineer). Each building has several heat exchangers per building with corresponding Design Envelope 4300 pumps. In very hot climates all year cooling may be required. In more temperate climates, with no cooling during the winter season, the design engineer may decide to provide a single heat exchanger for cost savings. Additionally, the design engineer may opt to delete the pressure break heat exchanger, though, the control valve location and logic will remain the same (with or without the heat exchanger).

Conventional plant solutions are designed around what is considered standard industry best practice (with base mounted pumps and variable frequency drives [VFDs] mounted remotely

to a wall). For example, when it comes to balancing large constant flow systems, general practice is to either trim the impeller or utilise a variable frequency drive running at a reduced speed to balance the constant flow. With Design Envelope pumps we presume the best industry practice of utilising the VFD for flow balancing. However, if VFDs for flow balancing are not being used in a specific project, this needs to be taken into account in the cost analysis.

Utilisation of VFDs on larger pumps (condenser water pumps in this case) often times also acts as a soft-start strategy — substantially reducing inrush currents.

The use of variable flow pump technology on each circuit enables a flexible platform on which an all-variable control system can be established.

The most likely chiller selection is a variable speed compressor-based machine with an advanced microprocessor controller. The most likely cooling tower configuration is a variable-water flow design that is able to leverage the advantages of maximised cooling tower surface area.

**PLANT AUTOMATION / CONTROL STRATEGY  
DESIGN ENVELOPE VS. CONVENTIONAL**

	Design Envelope plant	Conventional plant
Control platform	Plant automation system IPC 11550	Building Management System (BMS) - plant control module
System control sequence	Digital demand based control curves	Capacity based sequencing with cooling tower water temperature reset, fan speed control and PID feedback loop
Optimisation sequence	All Variable Speed plant automation, with equal marginal performance principle speed optimisation, load reset and natural curve sequencing	Variable Primary CHW flow (VPF) control loop, with both chilled water supply temperature reset and condenser water (LTWT) reset
Plant equipment architecture	All variable speed plant with Variable Primary CHW Flow (VPF), variable air flow cooling towers and variable flow condenser water	Variable primary CHW flow (VPF), with variable air flow cooling towers and constant flow condenser water
Performance & diagnostic management	Performance Ratio based real-time plant equipment and sequencing diagnostics, with sensitivity to 5% of targeted efficiency using ECO*PULSE	BMS alarms sent to facility operator based on pre-fixed limits for temperature or "on/off", when compared to settings

Design Envelope plant	Conventional plant
Primary loop- IPC 11550 <ul style="list-style-type: none"> <li>▪ Pump speed controlled via a combination of return water temperature and primary flow meter</li> <li>▪ Natural curve sequencing of chillers</li> </ul>	Primary loop- BMS controls <ul style="list-style-type: none"> <li>▪ Pump speed controlled via a combination of return water temperature and primary flow meter</li> <li>▪ Capacity-based staging of chillers</li> </ul>
Secondary loop- IPC 11550 <ul style="list-style-type: none"> <li>▪ Pumps are controlled by the IPC 11550 controller where it receives the tertiary loop valve positions from each tertiary IPS 4000 controller</li> </ul>	Secondary loop- BMS controls <ul style="list-style-type: none"> <li>▪ Pump speed/alternation to maintain differential pressure at each of the energy transfer stations</li> </ul>
Tertiary loop- IPS 4000 <ul style="list-style-type: none"> <li>▪ Pumps are controlled by the IPS 4000, and the IPS 4000 also controls the return water valve temperature on the secondary loop. Communicates valve position to the IPC 11550</li> </ul>	Tertiary loop- BMS controls <ul style="list-style-type: none"> <li>▪ Pump speed/alternation to maintain differential pressure building loop</li> <li>▪ Valve on heat exchanger controls secondary return loop temperature back to chilled water plant</li> </ul>
Condenser loop- IPC 11550 <ul style="list-style-type: none"> <li>▪ Variable flow condenser water pumping according to the Equal Marginal Performance Principle</li> </ul>	Condenser loop- BMS controls <ul style="list-style-type: none"> <li>▪ Condenser pump staging is constant flow with the number of pumps matching the number of chillers</li> </ul>
Tower loop- IPC 11550 <ul style="list-style-type: none"> <li>▪ Tower fan speed controlled by Equal Marginal Performance Principle</li> <li>▪ Tower staging based on natural curve sequencing</li> </ul>	Tower loop- BMS controls <ul style="list-style-type: none"> <li>▪ Fans controlled by variable speed drive to maintain leaving tower set point</li> </ul>
Remote plant energy efficiency monitoring <ul style="list-style-type: none"> <li>▪ Eco*Pulse for 1<sup>st</sup> year of operation</li> </ul>	Remote plant monitoring <ul style="list-style-type: none"> <li>▪ BMS controls for critical alarm notification only</li> </ul>

The Design Envelope plant employs an Integrated Plant Control System, IPC 11550. The IPC is at the core of operating all the variable speed/variable flow equipment in unison in order to supply the exact cooling load required at the lowest possible energy and water usage. In comparison, traditional BMS control/silo operation typically incurs much higher installed and operating/energy cost.

In addition to the IPC, the Design Envelope plant utilises the Integrated Pump Control System, IPS 4000. The IPS provides both, parallel sensorless pumping and control of the 2-way valves in each building. The IPS reads the position of each valve, communicates the information back to the IPC, and thus ensures all valves are kept open as much as possible at any given time to minimise pressure drops for energy-efficient operation.

How do we ensure a high-efficiency system is delivered to the owner? And how do we build in automatic measurement and verification? Every IPC installation comes with a free 1<sup>st</sup> year subscription to ECO\*Pulse, Armstrong's HVAC health management system. ECO\*Pulse includes automatic daily email notifications on plant performance, a user-friendly web interface, and quarterly performance reports prepared by Armstrong experts. Additional information regarding the IPC 11550, IPS 4000 and Eco\*Pulse can be found on the Armstrong web site.

With conventional chiller plant designs, combining variable primary and variable secondary pumping can pose serious challenges to the controls vendors. BMS vendors have to ensure that the primary pump flow matches the secondary pump flow - which typically is accomplished through a combination of flow meters and temperature sensors.

Care must be taken in the selection of the centrifugal chillers to verify a) they can handle variable flow through their evaporators, b) they can handle the expected changes in flow rates, and c) they can handle the expected minimum flow rate through their evaporators. Typically, a minimum of 40% or less primary chilled water flow will provide respectable energy savings from the primary CHW pumps. The lower the flow turndown on the chillers, the more the primary flow can be reduced at part load.

The secondary and tertiary pump speeds are traditionally controlled via differential pressure sensors or valve position. The valve on the cold side (i.e. secondary side) of the heat exchanger is controlled to return a fixed temperature back to the central plant. The set-point is the desired return water temperature to the chilled water plant. Many large campus plants employ pressure independent valves on the tertiary pumping to ensure sustained high return water temperatures.

Equipment is staged according to capacity, that is, once a chiller nears full capacity, the next chiller in line kicks in.

In certain applications and geographies, the cooling towers need to be selected so that multiple towers can handle the flow from a single condenser pump. For example, if one chiller and one condenser pump are in operation, more than one tower needs to be operating.

The BMS provides traditional remote alarms via e-mail, etc., to the building operators.

**LARGE CHILLED WATER PLANT  
BASE CASE INSTALLATION**

University complex: Cairo, Egypt

**Technical details:**

5,000 ton load; 6 chillers @3,500 kW each; 6 towers; 7 variable condenser pumps, 6 variable primary pumps and 3 variable secondary pumps, 5 buildings 3,500 kW each served by 2 variable tertiary pumps and 2 heat exchangers

**Design conditions (without redundancy):**

- 5,000 ton plant load, 3.9°C supply, 10.6°C return
- 5 Buildings, 1,000 ton each with tertiary flow 454 m<sup>3</sup>/h @ 15 m with heat exchanger
- Primary flow 2,270 m<sup>3</sup>/h @ 15 m without flow redundancy
- Secondary flow 2,270 m<sup>3</sup>/h @ 46 m without flow redundancy
- Condenser flow 3,405 m<sup>3</sup>/h @ 21 m without flow redundancy
- Outdoor ambient design 38°C dry bulb, 26°C wet bulb
- Cooling tower fan 55 kW per cell
- Design entering condenser water temperature of 29°C, 5.5 COP full load power draw per chiller

**DESIGN ENVELOPE BENEFITS SUMMARY**

Design Envelope benefit	Design Envelope savings over conventional plant
Lowest installed cost	£290,926
Lowest operating cost	Annual £227,501
Lowest environmental cost/impact	Annual reduction in greenhouse gas emissions (tonnes): 742
Lowest project and operating risk	(See table on page 10)
<b>Total Design Envelope 1<sup>st</sup> year savings</b>	<b>£518,486 (26%)</b>

By incorporating Design Envelope and Integrated Plant Control we are able to provide a lower carbon footprint, more efficient and more economical first cost solution whilst maintaining flexibility and lower life cycle costs.

With Armstrong Design Envelope solutions, customers will enjoy major savings on all levels: lowest installed and operating costs, lowest environmental impact and lowest project risks. In this example the savings amounts to a staggering **£518,000**.

A breakdown of the total savings is explained in detail in the following pages.



## LOWEST INSTALLED COST

Savings area	Design Envelope plant installed savings
Material & installation	£228,700
Time (labour)	included in material & installation
Power infrastructure	110 kW (150 hp)
Space	£59,076
Civil structure	included in material & installation
Utility rebates	Not applicable in Egypt
Commissioning & call backs	£3,150
<b>Total installed savings</b>	<b>£290,926 (34%)</b>

Through optimised Design Envelope pump selections, we are able to select equipment for the same flow and head duty, but with smaller kW motors where we are able to integrate the control/VFD into the pump.

The table above summarises the achieved savings for the example installation for the total lowest installed cost.

We are converting every pump from horizontal base mounted pumps with the VFDs mounted on an adjacent wall to Armstrong Design Envelope pumps.

### The benefits of Armstrong Design Envelope pumps:

- Free up wall space by fully integrating pumps and controls
- Wiring savings (material and labour) between wall-mounted VFDs and pumps
- In many selections, a smaller sized pump motor for the same design conditions
- Eliminate the inertia base, concrete, coupling alignment, housekeeping pad, and flexible connections for the traditional pumps
- Design flow can be balanced and verified right on the pump controls as they now function as an integrated flow meter
- For secondary and tertiary pumping, the differential pressure sensors can be removed for additional installation cost savings
- Reduction in mechanical floor space
- Commissioning savings (no DP sensors or VFDs on wall)

## LOWEST OPERATING COST

Savings area	Design Envelope plant operating savings (annually)
Energy	£159,340
Maintenance	(£50/hour) £5,514
Reliability	(increased availability) 10%
Water	£45,319
Operator labour	(£50/hour) £5,514
Target Mtce avoids failure (E*P)	£11,815
<b>Total operating savings</b>	<b>£227,501 (20%)</b>

Energy savings in the example installation stem from the unique combination of Design Envelope pumping and IPC 11550 control solutions. The savings result from operating the Design Envelope pumps at optimum system efficiency at all times using sensorless technology (instead of controlling pump speed based on DP sensors across the pumps).

When it comes to maintenance, seal changes on Design Envelope pumps are considerably faster than on conventional base mounted pumps. In addition, Armstrong Design Envelope pumps eliminate the need for shaft alignments – which are necessary after seal changes on base mounted pumps.

Cooling towers evaporate water in order to reject heat from the building inside. The heat is made up of two components. On the one hand there is the actual building heat and on the other there is the heat generated by the various motors driving the cooling system. The Design Envelope IPC 11550 operates equipment so efficiently that the motor related heat component is greatly reduced – therefore minimising the load on the cooling towers. In turn this also means less water is being used for evaporation. This can lead to significant cost savings, especially in regions where water is scarce or expensive.

Design Envelope pumps and IPC 11550 continuously inform operators about the pump flow and overall system condition, allowing them to troubleshoot directly from both devices (instead of doing guess work on remote and rather inaccessible components such as DP sensors).

By diagnosing plant operation on a continuous basis, the Eco\*Pulse health management system helps identify and prevent imminent plant failures before they occur. Moreover, Eco\*Pulse quickly detects performance drifts of 5% or greater, which, in conventional BMS alarm systems, oftentimes go unnoticed for extended periods of time. For instance, if a piece of equipment has been left in manual mode a BMS is unable to notice and correct related negative impacts on overall system efficiency.

## LOWEST ENVIRONMENTAL COST

Savings area	Design Envelope plant environmental savings	
Carbon footprint (energy)	(ton GHG [90% NG, 10% hydro])	742
Concrete infrastructure	(cubic metres of concrete)	38

Above carbon savings were calculated using the Armstrong carbon footprint calculator. The tool accounts for the actual amount of electricity saved as well as the fuel mix for generation used by the local power utility. According to 2013 US EIA data, the electrical grid in Egypt deploys a mix of 10% hydro and 90% natural gas power.

Savings in concrete are based on conventional pump infrastructure not needed for Design Envelope pumps, such as inertia bases and housekeeping pads.

## LOWEST PROJECT AND OPERATING RISK

Risk to	Risk source	Design Envelope plant risk reduction	% of total mechanical project
General contractor	Commissioning delay and payment delay of hold back amounts	£80,081	1.5%
Owner (capital projects)	Inevitable design changes by different stakeholders	£28,882	0.5%
Owner (operations and maintenance)	Energy and operational savings not achieved	£227,771	4.2%
Engineer	Reputation deterioration and losing new business	£81,394	1.5%
Mechanical contractor	Commissioning delay and payment delay of hold back	£30,194	0.6%

Reduced project risks were estimated based on avoided labor (when using Design Envelope technology over conventional practices) by contractors and engineers for:

- Installing and troubleshooting remote differential pressure sensors,
- Wiring pump motors to their corresponding VFDs, and
- Manually balancing system flow.

Project risk is further mitigated by commissioning the system using the Design Envelope IPC 11550 versus a conventional BMS.

PROCESS & INSTRUMENTATION DIAGRAM

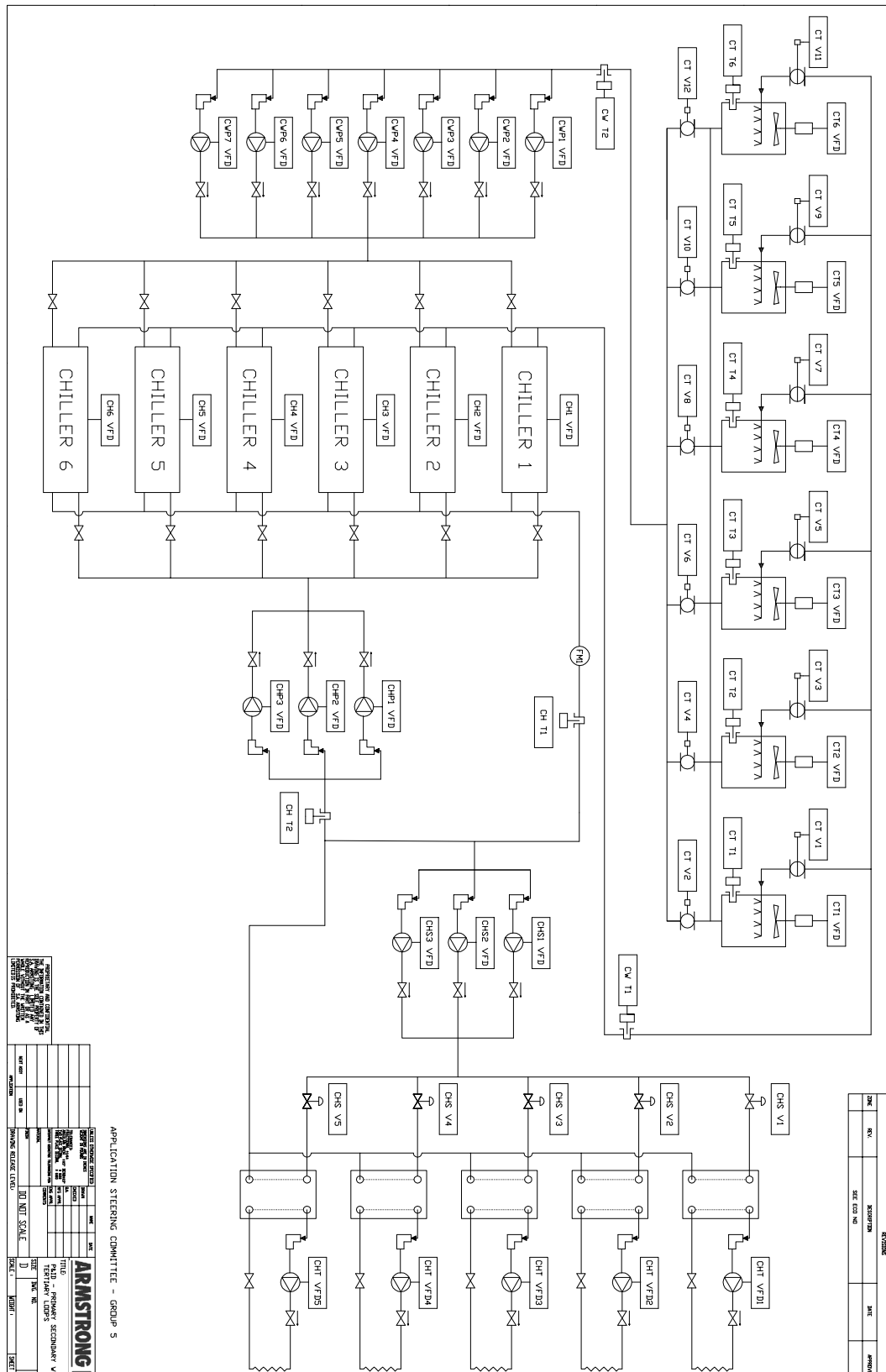

**TORONTO**

23 BERTRAND AVENUE  
TORONTO, ONTARIO  
CANADA  
M1L 2P3  
+1 416 755 2291

**BUFFALO**

93 EAST AVENUE  
NORTH TONAWANDA, NEW YORK  
U.S.A.  
14120-6594  
+1 716 693 8813

**BIRMINGHAM**

HEYWOOD WHARF, MUCKLOW HILL  
HALESOWEN, WEST MIDLANDS  
UNITED KINGDOM  
B62 8DJ  
+44 (0) 8444 145 145

**MANCHESTER**

WOLVERTON STREET  
MANCHESTER  
UNITED KINGDOM  
M11 2ET  
+44 (0) 8444 145 145

**BANGALORE**

#59, FIRST FLOOR, 3RD MAIN  
MARGOSA ROAD, MALLESWARAM  
BANGALORE, INDIA  
560 003  
+91 (0) 80 4906 3555

**SHANGHAI**

NO. 1619 HU HANG ROAD, XI DU TOWNSHIP  
FENG XIAN DISTRICT, SHANGHAI  
P.R.C.  
201401  
+86 21 3756 6696

**MAKING  
ENERGY  
MAKE  
SENSE™**