

Design Envelope 4200H & 4280

End suction horizontal
pumping units with
IVS drive

Installation and
operating instructions

File No: 103.80IEC
Date: DECEMBER 05, 2023
Supersedes: 103.80IEC
Date: NOVEMBER 20, 2023

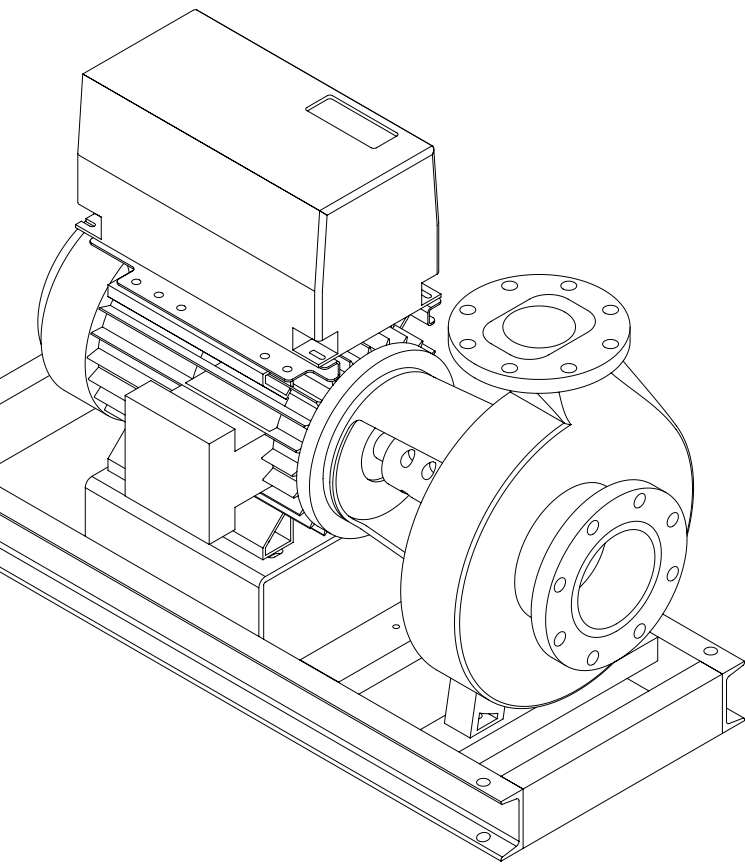

CONTENTS

1.0 INTRODUCTION	4
1.1 PRECAUTIONS	4
1.1.1 INSTRUCTIONS FOR SAFE USE	4
1.1.2 AMBIENT TEMPERATURE	4
1.1.3 ENCLOSURE RATING	4
1.1.4 NOISE LEVELS	4
1.1.5 VIBRATION LEVELS	5
1.1.6 STORAGE	5
1.1.7 WARRANTY	5
1.1.8 UNCRATING	5
1.1.9 HANDLING DESIGN ENVELOPE 4200H & 4280 PUMPING UNITS	5
1.2 MECHANICAL INSTALLATION	6
1.2.1 LOCATION	6
1.2.2 INSTALLATION	6
1.2.3 GROUTING	6
1.2.4 PUMP PIPING – GENERAL	7
2.0 ELECTRICAL SETUP	8
2.1 REMOVE COVER	8
2.2 PRECAUTIONS	8
2.2.1 GROUND LEAKAGE CURRENT	8
2.2.2 START / STOP OF PUMP	8
2.2.3 ADDITIONAL MOTOR PROTECTION	9
2.3 ELECTRICAL INSTALLATION	9
2.3.1 SUPPLY VOLTAGE	9
2.3.2 SUPPLY FUSING	9
2.3.3 GROUNDING AND IT MAINS	9
2.3.4 RELAY CONNECTIONS	10
2.3.5 ELECTRICAL AND CONTROL CONNECTIONS	12
2.3.6 CONTROL TERMINALS	13
2.4 DESIGN ENVELOPE PUMP CONTROLLER WIRING	15
2.4.1 BATTERY	15
2.4.2 ETHERNET AND WIFI CONNECTIVITY	15
2.4.3 CAN BUS WIRING	15
2.4.4 RS 485 WIRING	15
2.4.5 NETWORKING OPTIONS	15

3.0 NETWORKING CONTROLS	16	5.8 PARALLEL SENSORLESS PUMP CONTROL (PSPC)	39
3.1 MODBUS REGISTER MAP – VERSION 1 – FOR FIRMWARE V1.16 AND OLDER	17	5.8.1 EMBEDDED PARALLEL SENSORLESS PUMP CONTROL FOR MULTIPLE PUMPS	39
3.2 BACNET OBJECTS – VERSION 1 – FOR FIRMWARE V1.16 AND OLDER	19	5.8.2 MODIFYING MOTOR RAMP UP AND DOWN TIME	40
3.3 MODBUS REGISTER MAP – VERSION 2 – FOR FIRMWARE V1.17 AND NEWER	20	5.8.3 THREE DIFFERENT CONTROL MODES CAN BE ACCESSED	41
3.4 BACNET OBJECTS – VERSION 2 – FOR FIRMWARE V1.17 AND NEWER	22	5.8.4 FALLBACK PERCENTAGE OF MAXIMUM SPEED	41
4.0 OPERATION	24	5.8.5 STANDBY PUMPS	41
4.1 START-UP CHECKLIST	24	5.9 2*100% CAPACITY SPLIT UNITS	41
4.2 STARTING PUMP	24	5.10 ALTERNATION	41
4.2.1 AUTO FLOW BALANCING	24	5.11 CONSTANT PRESSURE CONTROL	42
4.3 TOUCH SCREEN	25	5.12 DUAL SEASON SETUP	42
4.3.1 LOGIN	25	5.13 SENSORED CONTROL	42
4.3.2 LOGOUT	25	5.14 BYPASS VALVE CONTROL	43
4.3.3 ABOUT	26	6.0 MAINTENANCE	45
4.3.4 GENERAL SETTINGS	27	6.1 GENERAL CARE	45
4.3.5 MANUAL/AUTO MODE	28	6.2 LUBRICATION	45
4.3.6 PUMP CONTROL	29	6.3 MECHANICAL SEAL	45
4.3.7 ALARMS & WARNINGS	31	6.3.1 MECHANICAL SEAL REPLACEMENT INSTRUCTIONS FOR 4200H SPLIT COUPLED VERTICAL IN-LINE PUMP	45
4.3.8 TREND-GRAPH	32	6.3.2 MECHANICAL SEAL REPLACEMENT INSTRUCTIONS FOR 4280 CLOSE COUPLED VERTICAL IN-LINE PUMP	47
4.3.9 BRIGHTNESS ADJUSTMENT	32	7.0 WARNINGS AND ALARMS	48
4.3.10 TOUCH SCREEN CALIBRATION	33	7.1 ALARM SUMMARY FOR INTERFACES	48
4.3.11 DATA LOGGING	34	7.2 WARNING SUMMARY FOR INTERFACES	49
4.4 WEB INTERFACE	35	8.0 FUSE AND WIRE RECOMMENDATION	50
4.4.1 CONNECTING VIA ETHERNET	35	9.0 PUMP MANAGER	51
4.4.2 CONNECTING VIA WIFI	35	10.0 CONNECTIVITY KIT	51
4.4.3 SWITCHING FREQUENCY	37		
4.5 DESIGN ENVELOPE FLOW READOUT TOLERANCE	37		
5.0 CONTROL MODES	38		
5.1 CONSTANT FLOW	38		
5.2 CONSTANT PRESSURE	38		
5.3 LINEAR PRESSURE	38		
5.4 QUADRATIC CURVE CONTROL	38		
5.5 QUADRATIC CURVE CONTROL WITH MINIMUM FLOW PROTECTION	38		
5.6 QUADRATIC CURVE CONTROL WITH MAXIMUM FLOW PROTECTION	38		
5.7 QUADRATIC CURVE CONTROL WITH MINIMUM & MAXIMUM FLOW PROTECTION	39		

1.0 INTRODUCTION

This manual contains specific information regarding the safe installation, operation and maintenance of Armstrong Design Envelope pumps. Read this manual carefully before installing or using the product. If clarification is needed on any point please contact Armstrong quoting the equipment serial number.

1.1 PRECAUTIONS

1.1.1 INSTRUCTIONS FOR SAFE USE



No installation of this equipment should take place unless this document has been studied and understood. Handling, transportation and installation of this equipment should only undertaken by trained personnel with proper use of lifting equipment. See later diagrams for lifting advice. Refer to the pump nameplate for pump speed, pressure and temperature limitations. The limits stated must not be exceeded without written permission from Armstrong.

1.1.2 AMBIENT TEMPERATURE



Install the Design Envelope unit with adequate access for routine maintenance. A minimum of 2" (50 mm) clearance is required at the fan inlet to facilitate airflow. Where several Design Envelope units are installed in close proximity, care must be taken to ensure that there is no re-circulation of exhausted warm air.

Under normal operating conditions the pump surface temperature may reach 68°C/ 155°F (Restricted Zone) to 80°C/176°F (Unrestricted Zone). Steps should be taken to minimize contact or warn operators/users that normal operating conditions will be exceeded. In certain cases where the temperature of the pumped liquid exceeds the above stated temperature levels, pump casing temperatures may exceed 100°C/212°F and not withstanding pump insulation techniques appropriate measures must be taken to minimize risk for operating personnel. The ambient temperature for standard motors must be no greater than 45°C/ 113°F.

1.1.3 ENCLOSURE RATING



The standard enclosure rating for Design Envelope 4200H and Design Envelope 4280 integrated controls is UL Type 12 / IPP55. If the pump is to be installed in a wet or dusty environment, then a higher enclosure rating may be required (contact Armstrong).

1.1.4 NOISE LEVELS

Typical Pumping Unit Sound Pressure Level, Decibels, A-Weighted, at 1 m (3 ft.) from unit.

FRAME DESIGNATION	1500 RPM				3000 RPM			
	FCM		TEFC		FCM		TEFC	
	kW	db-A	kW	db-A	kW	db-A	kW	db-A
80	0.55-0.75	55	0.55-0.75	47	0.55-0.75	55	0.55-1.1	58
90	1.1-1.5	60	1.1-1.5	49	1.1-1.5	60	1.5-2.2	62
100	2.2	59	2.2	53	2.2	59		
100	3	62	3	53	3	62	3	64
112	4	64	4	54	4	63	4	66
132	5.5-7.5	62	5.5-7.5	60	5.5-7.5	62	5.5-7.5	69
160			11-15	63			11-18.5	74
180			18.5-22	65			22	75
200			30	65			30-37	78
225			37-45	66			45	78
250			55	67			55	81
280			75-90	70			75-90	81
315			110-132	78			110-132	82
315			160-200	83			160-200	86
355			250-315	85			250-315	89

1.1.5 VIBRATION LEVELS

Armstrong end-suction horizontal pumps are designed to meet vibration levels set by Hydraulic Institute Standard HI Pump Vibration 9.6.4. Standard levels are as detailed below

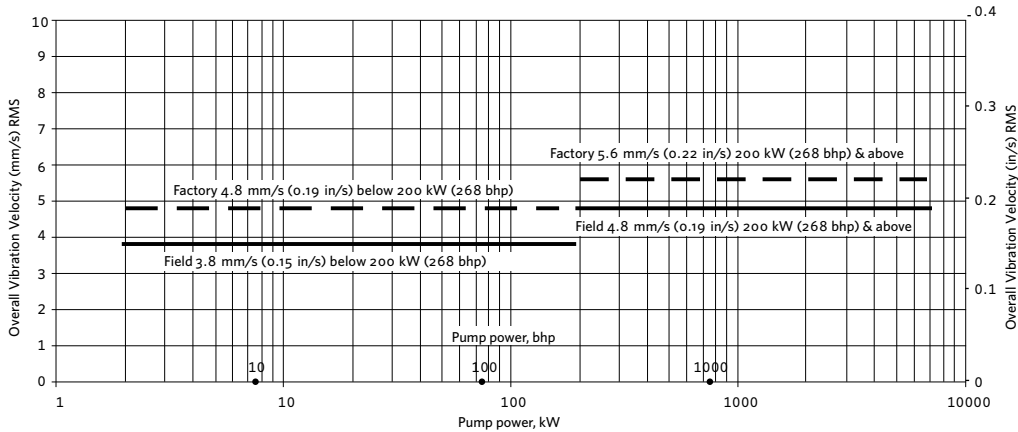

1.1.6 STORAGE

Pumps not immediately placed into service, or removed from service and stored, must be properly prepared to prevent excessive rusting. Pump port protection plates must not be removed until the pump is ready to connect to the piping.

Rotate the shaft periodically (at least monthly) to keep rotating element free and bearings fully functional.

For long term storage (longer than three months), the pump must be placed in a vertical position in a dry environment.

Internal rusting can be prevented by removing the plugs at the top and bottom of the casing and drain or air blow out all water to prevent rust buildup or the possibility of freezing. Be sure to reinstall the plugs when the unit is made operational. Rust proofing or packing the casing with moisture absorbing material and covering the flanges is acceptable. When returning to service be sure to remove the drying agent from the pump.

1.1.7 WARRANTY

Armstrong's warranty period for Design Envelope pumps is [18] months from date of shipment, or [12] months from date of installation, whichever comes first. Please refer to File 9.10UK/9.10IN/9.10CH for full terms and conditions. To receive an additional [6] months of standard coverage, owner may register the pump unit at www.armstrongfluidtechnology.com/warrantyregistration

1.1.8 UNCRATING

Armstrong pumping units are thoroughly inspected before shipment to assure they meet with your order requirements. After removing the pump from the packaging, make sure the equipment is in good order and that all components are received as called for on the packing list. Any shortages or damage should be reported immediately. Use extreme care

in handling the unit, placing slings and hooks carefully so that stress will not be imposed on the integrated controller, pump or motor. **Never place cable slings around the pump shaft or integrated controls.** The eye bolts or lifting lugs on the motor are intended for lifting only the motor and not the complete unit.

1.1.9 HANDLING DESIGN ENVELOPE 4200H & 4280 PUMPING UNITS

Design Envelope pumping units Series DE 4200H end-suction base mounted & DE 4280 end-suction close coupled units bring the convenience of 'plug & play' units, as pre-set controls are an integral component of the UL STD 778 & CSA STD C22.2 No 108 certified pumping units. These controls, though adding typical high value from lower installed cost for the installing contractor and inherent energy savings for the building owner, involve integrated controls that are not delicate though do need more care during installation than standard pump and motor components and must be handled accordingly.

Spacer bars for lifting straps or chains, may be used to ensure the straps or chains do not exert pressure the pump and motor housings and really must be used, with extra care, around the controls housing.

FIG 1.1 LIFTING HORIZONTAL DESIGN ENVELOPE PUMPS USING SPACER BEAMS

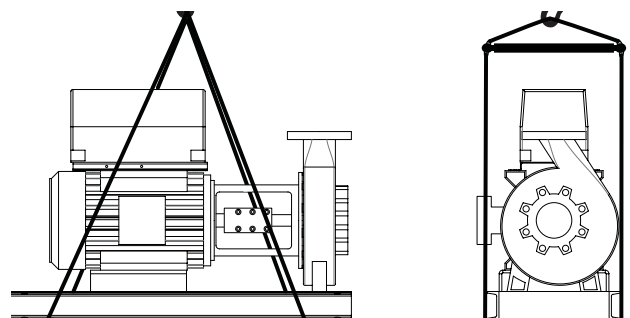

**FIG.1.2 LIFTING HORIZONTAL DESIGN ENVELOPE PUMPS
USING BASE LIFTING HOLES**

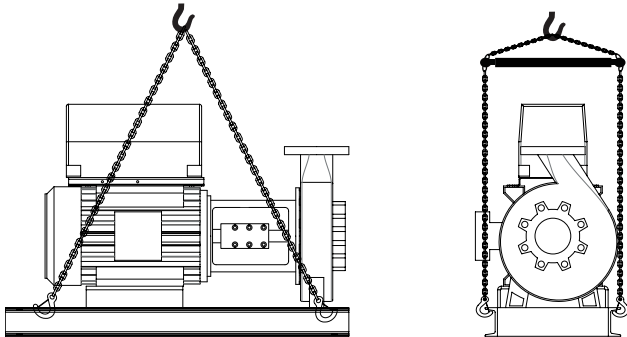
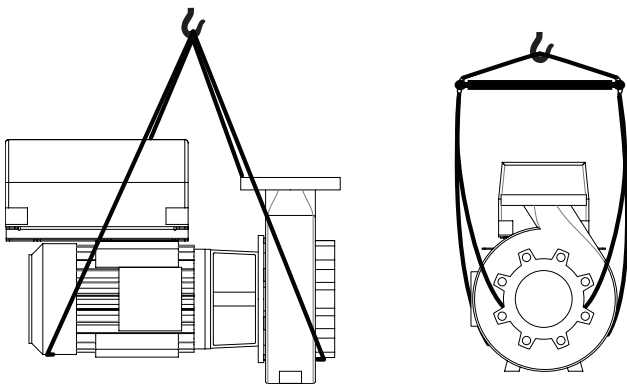

FIG.1.3 LIFTING CLOSE COUPLED DESIGN ENVELOPE PUMPS



IMPORTANT:



Do not run the pump for any length of time under very low flow conditions or with the discharge valve closed. To do so could cause the water in the casing to reach super heated steam conditions and will cause premature failure and could cause serious and dramatic damage to the pump and surrounding area.

1.2 MECHANICAL INSTALLATION

1.2.1 LOCATION

In open systems, locate the unit as close as practical to the liquid being pumped, with a short, direct suction pipe. Ensure adequate space is left above and around the unit for operation, maintenance, service and inspection of parts.

In closed systems, where possible, the pumps should be installed immediately downstream of the expansion tank / make-up connection. This is the point of zero pressure change and is necessary for effective pump operation. Do not install more than one expansion tank connection into any closed hydronic system. Electric motor driven pumps should not be located in damp or dusty location without special protection.

Airflow into the motor and/or motor fan should not be obstructed.

It is good practice to leave sufficient space around equipment for maintenance and service needs. If the Design Envelope

controls are supplied with integral disconnect switches, 36"/1 meter clearance may be required in front of the controls to meet local electrical codes.

1.2.2 INSTALLATION

The following text and illustrations are offered as general suggestions for the preparation of a satisfactory foundation.

Foundation should be sufficiently substantial to absorb any vibration and permanently support the baseplate at all points. This is essential in maintaining the alignment of a direct coupled unit.

If the unit is to be mounted on fabricated steel work or similar structure, the unit should be set over, or as near as possible to, the supporting beams or walls and to be so supported that the baseplate cannot be distorted by any yielding or springing of the structure or base.

The (4) corner holes should be used as a minimum. All (6) holes can be used on larger bases. Secure evenly spaced straps placed under the baseplate is also acceptable for lifting the entire unit.

Horizontal Design Envelope pumping units are supplied with rigid split couplings (DE 4200H) or are close-coupled (DE 4280), as such no alignment is necessary in the field.

Place pumping unit on the foundation and insert metal wedges on either side of the foundation bolts under base plate. Leave approximately 0.75" (19mm) space if grouting.

Carefully level the unit by adjusting the wedges until base is supported in a level position

With the proper gauge, check suction and discharge flanges of the pump for proper positioning.

When the baseplate is completely level, the foundation bolts should be tightened evenly and firmly.

1.2.3 GROUTING

Armstrong's fabricated steel base plates, as supplied with 4200H Design Envelope pumps, are manufactured to ANSI/HI 1.3.5 rigidity standards for free-standing base plates. As such, no grouting in place is necessary for the base plate to hold shaft alignment of any Armstrong base mounted pumping unit. End-suction horizontal base mounted Design Envelope pumping units are supplied with rigid couplings which need no re-alignment at installation or following seal service. Thus grouting is not necessary; though the following instructions are for installers who still wish to also secure the base in place with grout:

- Construct a dam around the foundation with grout forms, as shown in the illustration.
- Use a good mixture of non-shrinking grout. The grout should be the consistency of heavy cream.
- Spaces are provided in the base plate to permit pouring

of the cement and stirring. Fill under the base completely, stirring to assure proper distribution of the grout. Check to see that the grout flows under the base plate evenly.

- When the grout has hardened thoroughly, usually after 48 hours, final tighten the anchor bolts and remove the grout forms.

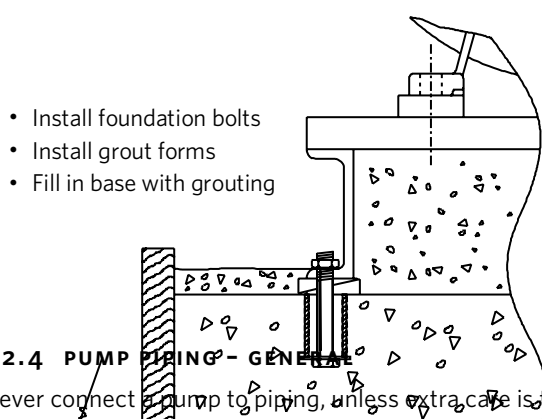

1.2.4 PUMP PIPING - GENERAL

Never connect a pump to piping, unless extra care is taken to measure and align the piping flanges well. Always start piping from pump.

Use as few bends as possible and preferably long radius elbows.

Do not use flexible connectors on the suction or discharge of a vertical in-line pump, unless the pump is rigidly mounted to a foundation.

Ensure piping exerts no strain on pump as this could distort the casing causing breakage or early failure due to pump misalignment.

All connecting pipe flanges must be square to the pipework and parallel to the pump flanges.

Suction and discharge pipes may be increased or decreased at pump nozzle to suit pump capacity and particular conditions of installation. Use eccentric reducers on suction connection with flat side uppermost.

Layout the suction line with a continual rise towards the pump without high points, thus eliminating possibility of air pockets that may prevent the pump from operating effectively.

A strainer of three or four times the area of the suction pipe, installed in the suction line, will prevent the entrance of foreign materials into the pump. $\frac{3}{8}$ " (3 mm) diameter perforations in the strainer is typical.

In open systems, test suction line for air leaks before starting;

this becomes essential with long suction line or static lift.

Install, at the pump suction, a straight pipe of a length equivalent to four or six times its diameter; this becomes essential when handling liquids above 120°F (49°C). Armstrong suction guides may be used in place of the straight pipe run and in-line strainer.

Install an isolation valve in both suction and discharge lines on flooded suction application; these valves are used primarily to isolate the pump for inspection or repair.

Install a non-slam non-return check valve in discharge line between pump and isolation valve to protect pump from excessive back pressure and to prevent water running back through the pump in case of driver failure on open systems. Armstrong Flo-Trex valves may be used in place of isolation valves and non-return check valves. Flo-Trex valves use plug & disk design which may also be used for throttling excessive system flow for constant speed pumps and, if necessary, for variable speed pumps. **Do not** throttle variable speed pumps unless absolutely necessary.

NOTE:

Design Envelope 4200H units are accurately aligned at the factory prior to being shipped and do not need re-aligning when installed.

Alignment on a Design Envelope 4200H unit may be verified by assuring an equal and parallel gap between coupling halves on both sides of the coupling.

2.0 ELECTRICAL SETUP

2.1 REMOVE COVER

Remove front cover to access mains and grounding connections, and control terminals. Carefully lift the cover from the bottom edge to remove. **DO NOT PRY** the cover open from the side edges.

When replacing the front cover, please ensure proper fastening by applying a torque of 2Nm.

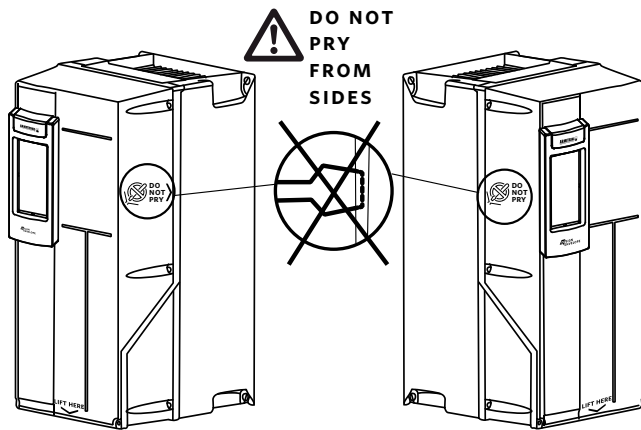
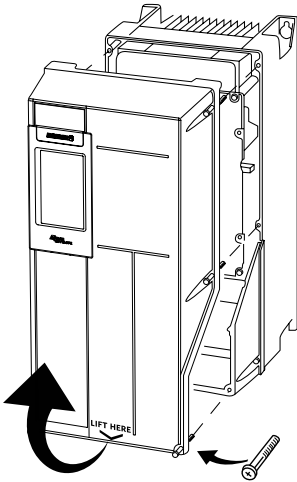

2.2 PRECAUTIONS



To avoid the ivs unit getting overheated, the ambient temperature is not to exceed 133°F (45°C) average daily temperature. Operating in higher ambient temperatures will require derating of the inverter.



All electrical connections should be carried out by a qualified and authorized electrician in accordance with local site regulations and the latest issue of the IEE regulations.

SAFETY, RISK OF DEATH



Before removing the inverter cover, the system must be disconnected from the mains supply. After switching off, wait for at least 15 minutes for the capacitors to discharge before opening the cover.

CAUTION



High voltage testing (Megging) of the motor/inverter may cause damage to the electronic components and therefore should not be carried out.

2.2.1 GROUND LEAKAGE CURRENT



Ground leakage current is primarily caused by the capacitance between motor phases and the motor frame. The RFI filter contributes additional leakage current, as the filter circuit is connected to ground through capacitors.

The size of the leakage current to the ground depends on the following factors, in order of priority:

- 1 Switching frequency
- 2 Motor grounded on site or not

The leakage current is of importance to safety during handling/operation of the pump if (by mistake) the on-board inverter has not been grounded.

Since the leakage current is >3.5mA (approx 4-20mA), reinforced Grounding must be established which is required if EN 50178 is to be complied with. Never use ELCB relays that are not suitable for DC fault currents (type A).

If ELCB relays are used, they must be:

- Suitable for protecting equipment with a direct current content (DC) in the fault current (three-phase bridge rectifier)
- Suitable for power-up with short charging current to Ground
- Suitable for a high leakage current

2.2.2 START / STOP OF PUMP

The number of starts/stops via the mains voltage must not exceed one-time per minute.

If a higher number of starts/stops is required then the start/stop digital input must be used (mains voltage directly connected). This is the preferred method of starting and stopping Pumps.

The three phase mains must be isolated before performing maintenance of the pump.

2.2.3 ADDITIONAL MOTOR PROTECTION



With the exception of supply fuses / MCB's to protect the installation (for over-current and short-circuit protection), no additional overload or over-temperature protection is required (i.e. thermal overloads). Protection features include:

- Mains phase loss
- Over voltage
- Under voltage
- Electronic thermal motor protection
- Short circuit on motor terminals
- Ground fault on motor terminals
- Over temperature

2.3 ELECTRICAL INSTALLATION

2.3.1 SUPPLY VOLTAGE

The supply voltage details can be found on the IVS nameplate. Please ensure that the unit is suitable for the electrical supply on which it is to be used. The mains supply for pumps is as follows:

1 × 200-240V ± 10%

3 × 200-240V ± 10%

3 × 380-480V ± 10%

3 × 525-600V ± 10%

Supply frequency - 50/60Hz

2.3.2 SUPPLY FUSING

Branch circuit protection

In order to protect the installation against electrical and fire hazard, all branch circuits in an installation, switch gear, machines etc., must be short-circuit and over-current protected according to the national/international regulations.

Short circuit protection

The inverter must be protected against short-circuit to avoid electrical or fire hazard. Armstrong recommends using the fuses detailed in the separate IVS Operating Instructions to protect service personnel or other equipment in case of an internal failure in the unit. The frequency converter provides full short circuit protection in case of a short-circuit on the motor output.

2.3.3 GROUNDING AND IT MAINS



The ground connection cable cross section must be at least 10 mm² or two rated mains wires terminated separately according to EN 50178 or IEC 61800-5-1 unless national regulations specify differently. Always comply with national and local regulations on cable cross sections.



The mains is connected to the main disconnect switch if this has been included.



Check the mains voltage corresponds to the mains voltage of the frequency converter name plate.



Do not connect frequency converters with RFI-filters to mains supplies with a voltage between phase and ground of more than 440 v for 400 v converters and 760 v for 690 v converters. For 400 v IT mains and delta earth (grounded leg), mains voltage may exceed 440 v between phase and earth. For 690 v IT mains and delta earth (grounded leg), mains voltage may exceed 760 v between phase and earth.

FIG. 2.1 Terminals for mains and grounding

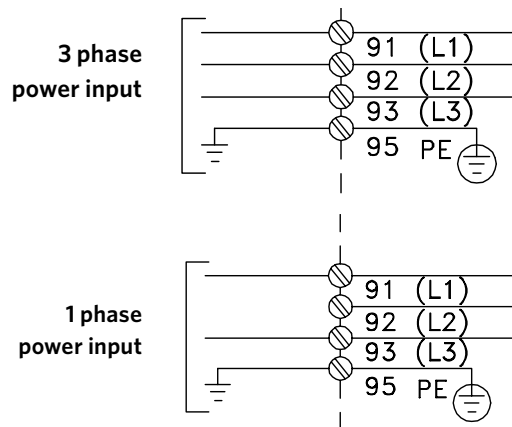

FIG. 2.2 Mains and grounding connections for A5 units (200-240V - 1.5HP 1PH/5HP and below 3PH, 380-480V/525-600V - 10HP and below)

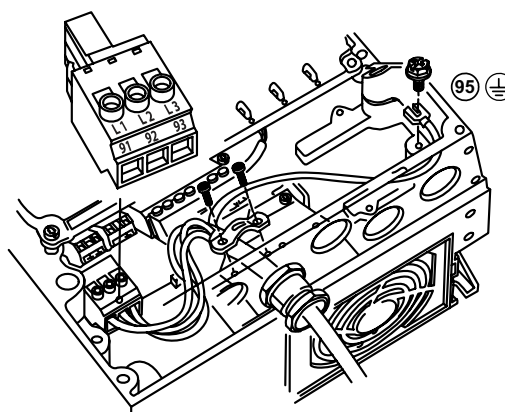

FIG. 2.3A Mains and grounding connections for B1 and B2 units (200-240V - 2 to 7.5HP 1PH/7.5 TO 20HP 3PH, 380-480V - 15 to 40HP, 525-600V - 15 to 50HP)

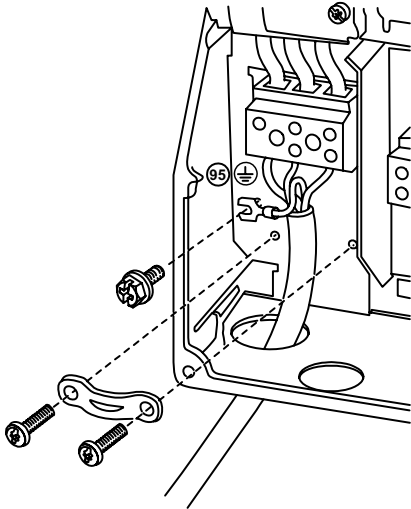

FIG. 2.3B Mains and grounding connections for C1 and C2 units (200-240V - 25 to 60HP, 380-480V - 50 to 125HP, 525-600V - 60 to 125HP)

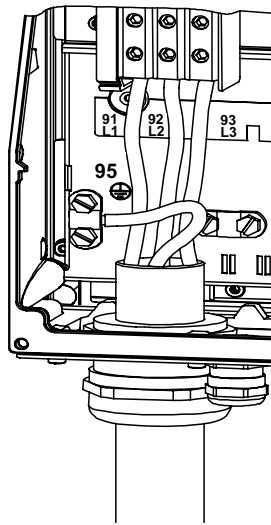
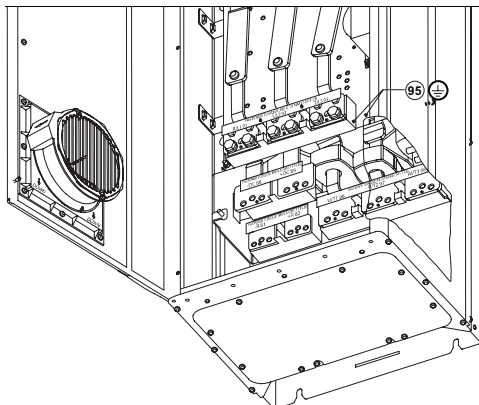

FIG. 2.3C Mains and grounding connections for D1 and B2 units (380-480V - 150 to 350HP, 525-600V - 150 to 350HP)



2.3.4 RELAY CONNECTIONS

The relays on the are configured as follows:

Relay 1 - ALARM

- Terminal 01: Common
- Terminal 02: Normal Open 240v AC
- Terminal 03: Normal Closed 240v AC

Relay 2 - RUN STATUS

- Terminal 04: Common
- Terminal 05: Normal Open 400v AC
- Terminal 06: Normal Closed 240v AC

FIG. 2.4 Relay contact details

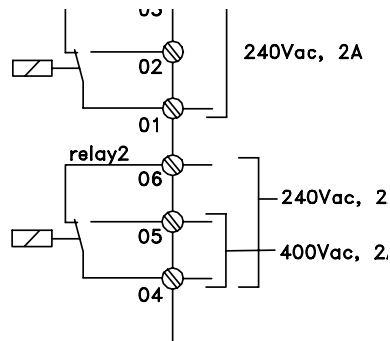

The following illustrations identify the location of the relays within specific inverter sizes:

The illustrations in figures 6, 7 and 8 identify the location of the relays within specific inverter sizes:

FIG. 2.5 Relay connection: terminals for A5, B1 and B2 units

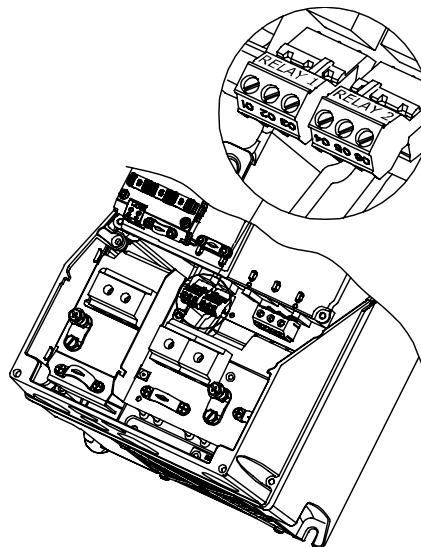

FIG. 2.6 Relay connection terminals for c1 and c2 units

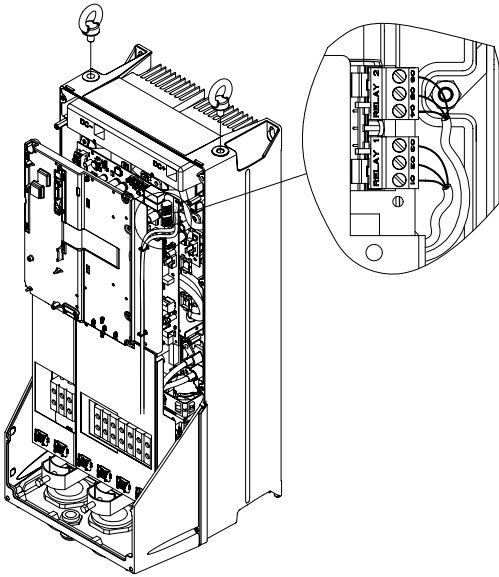
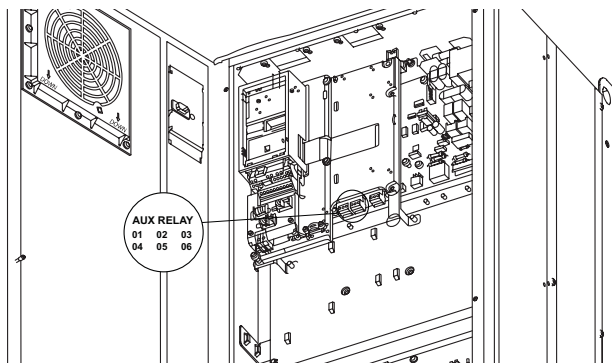

FIG. 2.7 Relay connection terminals for c1 and c2 units



2.3.5 ELECTRICAL AND CONTROL CONNECTIONS

FIG. 2.8 Diagram showing all electrical connections

***Note:** Terminal 37 is not available on Design Envelope pumps

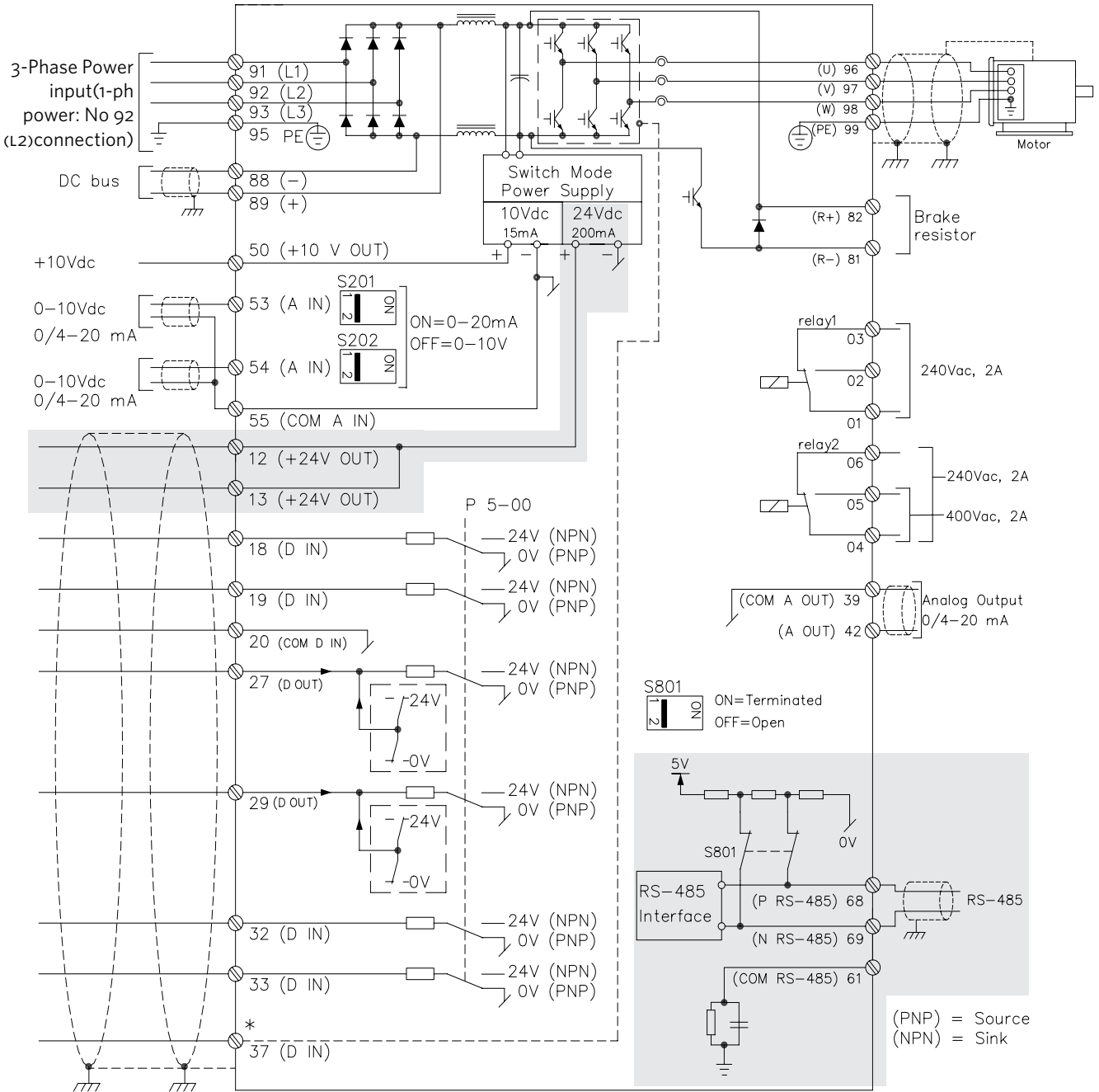

Reserved for control module

2.3.6 CONTROL TERMINALS

With reference to figure 10:

FIG. 2.9 Control Connections

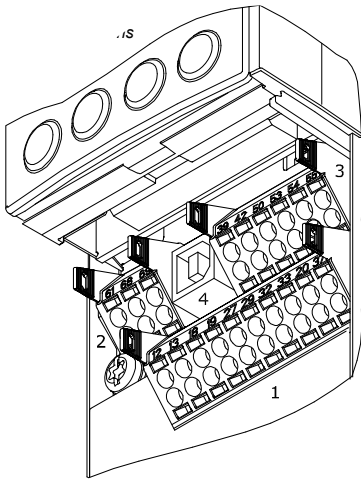

- 1 10-way plug for digital I/O
- 2 3-way plug for RS485 bus
- 3 6-way plug for analogue I/O

Inserting Cables into Control Terminals

- I Strip 10mm of insulation from the cable:
- II Insert a suitable terminal screwdriver as shown and then push the cable into the terminal.
- III Remove the terminal screwdriver and check the terminal has gripped the cable by gently pulling it.

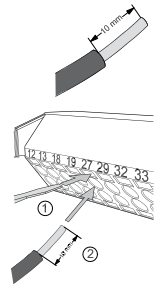

Note: Terminal plugs can be easily removed for improved access when making connections.

For connection to external devices such as start / stop switches, differential pressure sensors, or temperature sensors etc., refer to the following wiring instructions to the terminals and webserver configuration screens.

TERMINAL NO.	TYPE/ DESCRIPTION	FACTORY SETTING	WEBSERVER CONFIGURATION REF
1, 2, 3	Relay 1	Alarm	G
4, 5, 6	Relay 2	Run Status	G
18	Digital Input 1	Start / Stop	A
19	Digital Input 2	Start / Stop	B
27	Digital Output 1	Alarm, Flow Threshold, Head Threshold, Run Status	E
29	Digital Output 2	Alarm, Flow Threshold, Head Threshold, Run Status	F
42	Analog Output	Speed	
53	Analog Input 1	Speed Control, Pressure Sensor	C
54	Analog Input 2	Speed Control, Pressure Sensor	D

*Note that Analogue inputs A153 and A154 can be either Voltage (0-10v) or Current (4-20mA) input and by default both inputs are set to Voltage. Switches S201 and S202 (see figure 9) are used to configure the analogue inputs as follows:

S201 (A153) OFF = Voltage, ON = Current

S202 (A154) OFF = Voltage, ON = Current

WEBSERVER CONFIGURATION

Select **Pump** in the left side-menu

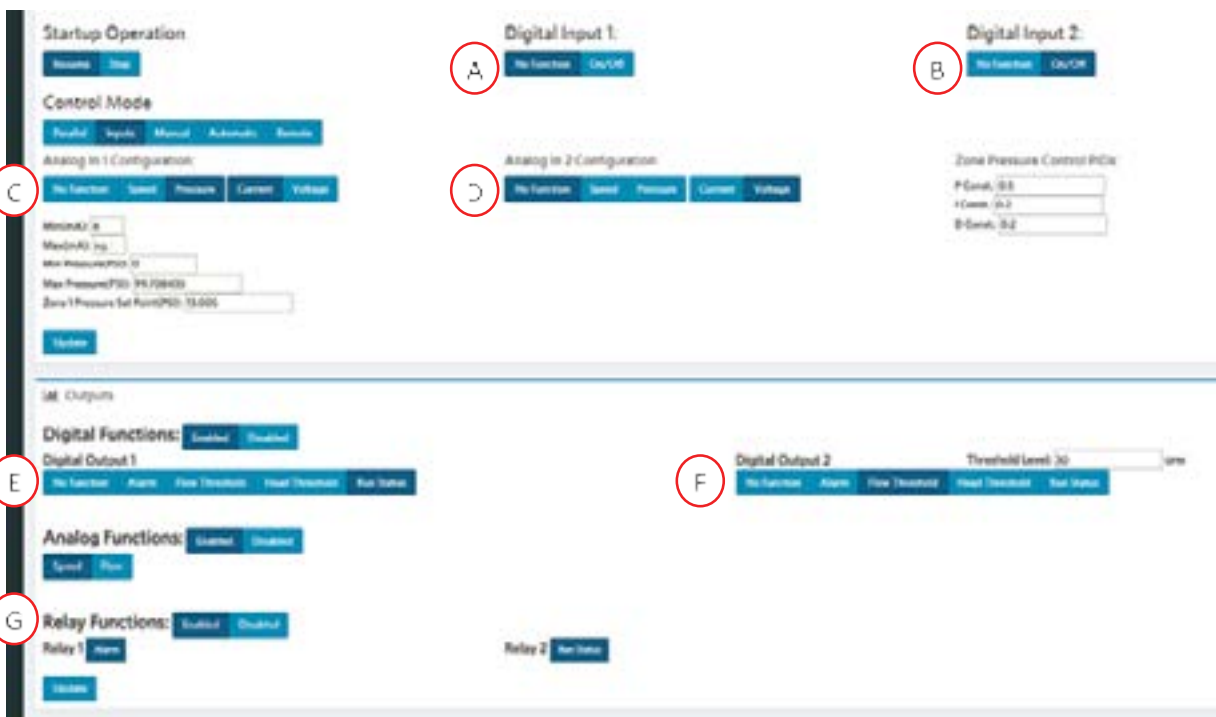

For Digital Inputs (A, B) that have been wired:

- 1 Select On/Off, then
- 2 Select Update

For Analog Inputs (C, D) that have been wired:

- 1 Select Speed or Pressure, for the control type
- 2 Select Current or Voltage,
- 3 Enter values in the text box (as applicable),
- 4 Select Update

For Digital Functions (E, F) that have been wired:

- 1 Select Enabled, then
- 2 Select one of Alarm, Flow Threshold, Head Threshold, or Run Status
- 3 Enter the threshold value in the text box (as applicable),
- 4 Select Update

For Digital Inputs (G) that have been wired:

- 1 Select Enabled, then
- 2 Select Alarm or Run Status,
- 3 Select Update

2.4 DESIGN ENVELOPE PUMP CONTROLLER WIRING

FIG. 2.10 Controller Board

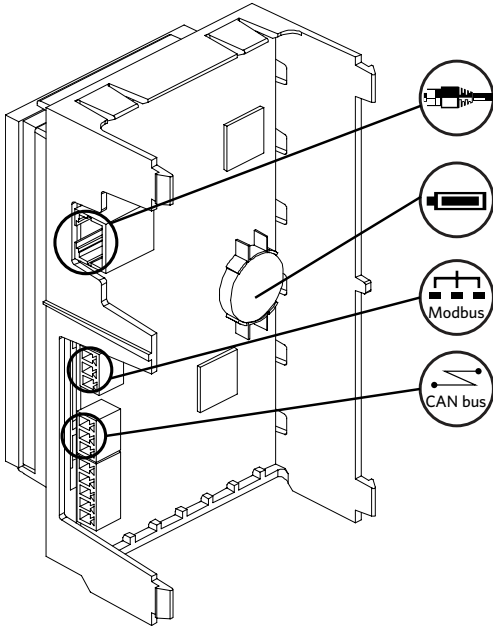
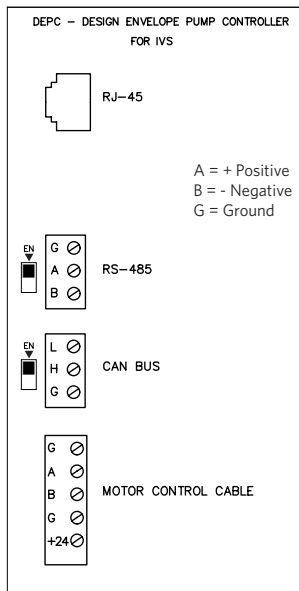

FIG. 2.10A Controller Board



2.4.1 BATTERY

The battery is used to power the real-time clock whenever the pump is disconnected from mains power. It is recommended the battery be changed periodically every 2 to 3 years.

2.4.2 ETHERNET AND WIFI CONNECTIVITY

For BACNet TCP/IP connection to building automation system, connect connect RJ-45 cable to this port per FIG. 2.10

2.4.3 CAN BUS WIRING

Connections, Low, High, and Ground as per FIG. 2.10. If the DEPC requires a CAN BUS connection, ensure that the terminating resistor switch is set to Enabled, (towards the EN label for the BAS ports). If multiple pumps are connected in parallel for CAN BUS (supplied by others) they should be daisy chained together. Ensure that only the first and last terminating resistor switches are set to Enabled.

2.4.4 RS 485 WIRING

For Modbus RTU or BACNet MS/TP connection to building automation system, connect RS485 cable to this port per FIG. 2.10. If the DEPC is connected to the BAS, ensure that the terminating resistor switch is set to Enabled (towards the EN label for the BAS ports).

If multiple pumps are connected in parallel to the BAS, the BAS wiring (supplied by others) should be daisy chained together. Ensure that only the first and last terminating resistor switches are set to Enabled. See example below in FIG 2.10.1

FIG. 2.10.1

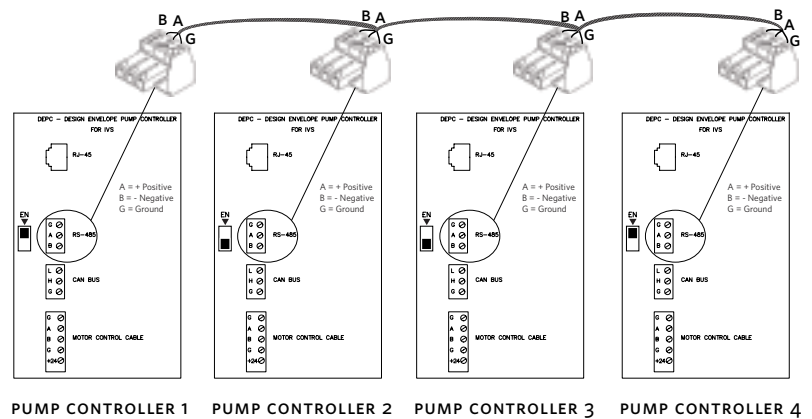

2.4.5 NETWORKING OPTIONS

FIG. 2.11

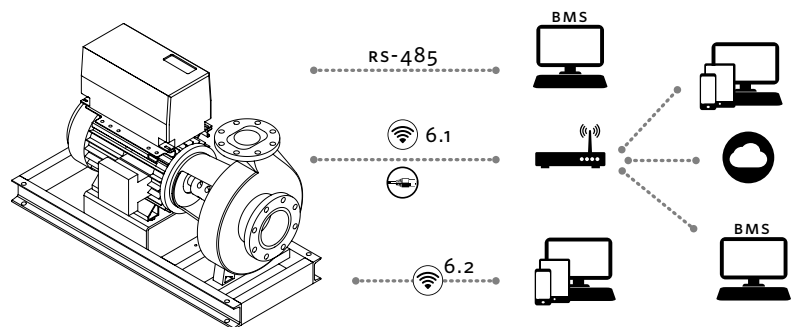

3.0 NETWORKING CONTROLS

For connection to the building automation system (BAS), the pump needs to be properly configured to the network. Ensure the RS485 cable is connected to the controller board (FIG. 2.10). Or if connecting to the bas via router, ensure that the RJ-45 cable is connected to the controller board (FIG. 2.10).

The pump controls can be configured from the touchscreen or the webserver.



For BACNet MS/TP or TCP/IP: Enter the BACNet address, baud rate, and unique device instance number (as applicable)

For Modbus RTU or TCP/IP: Enter the Modbus address, baud rate, and parity stop bits (as applicable)

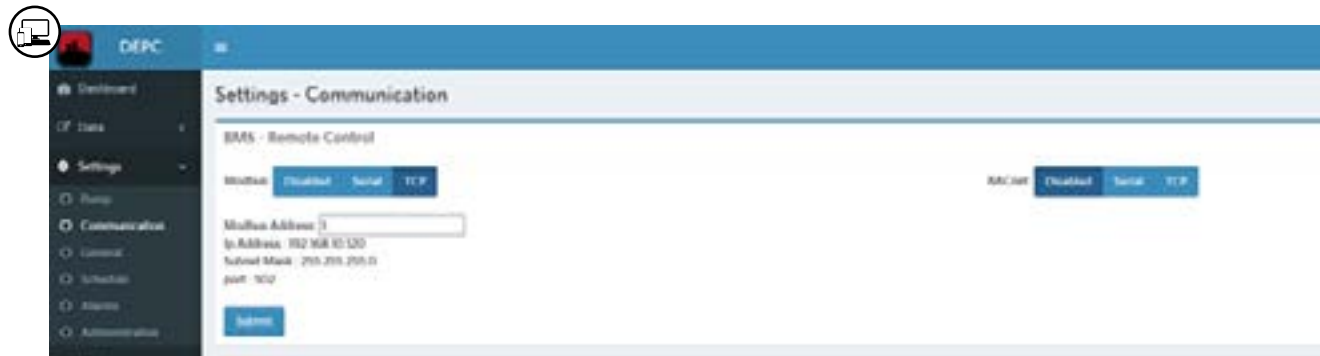

3.1 MODBUS REGISTER MAP - VERSION 1 - FOR FIRMWARE V1.16 AND OLDER

FUNCTION CODE		START ADDRESS	MODBUS REGISTER	DESCRIPTION	# OF REGISTERS	CHANGE DURING OPERATION	DATA TYPE	UNIT	NOTES
READ	WRITE								
0x03	0x06								
Status									
x		100	101	Actual Speed	1	N/A	UINT16	1 RPM	The current speed of the vfd in RPM.
x		101	102	Actual Speed	1	N/A	UINT16	0.1 %	The current speed of the vfd in % of the nominal motor speed.
x		102	103	Motor Power	2	N/A	UINT32	0.01	Units as configured on Pump Control Module.
x		104	105	Motor Input Voltage	1	N/A	UINT16	0.1 V	Voltage delivered by the vsd to the motor.
x		105	106	Motor Input Current	2	N/A	UINT32	0.01 A	Current delivered by the vsd to the motor.
x		107	108	Sensorless Head	2	N/A	UINT32	0.01	Units as configured on Pump Control Module.
x		109	110	Sensorless Flow	2	N/A	UINT32	0.01	Units as configured on Pump Control Module.
x		111	112	Total Flow	2	N/A	UINT32	0.01	Used for Parallel sensorless mode
x		113	114	Total Power	2	N/A	UINT32	0.01	Used for Parallel sensorless mode
x		115	116	Number of Running Pumps	1	N/A	UINT16	-	Used for Parallel sensorless mode
x		116	117	Max Sensorless Flow	2	N/A	UINT32	0.01	Units as configured on Pump Control Module.
x		118	119	Max Sensorless Head	2	N/A	UINT32	0.01	Units as configured on Pump Control Module.
x		122	123	Status	1	N/A	UINT16	-	Bit: 0 = pump run status (0=not rotating, 1=rotating)
I/O									
x		200	201	Digital In	1	N/A	UINT16	-	Digital input 1 is bit 0 and input 2 is bit 1.
x		201	202	Analog In 1	2	N/A	UINT32	0.01 V, 0.01 mA	Units as configured on Pump Control Module
x		203	204	Analog In 2	2	N/A	UINT32	0.01 V, 0.01 mA	Units as configured on Pump Control Module
x		205	206	Analog Out 1	1	N/A	UINT16	0.01 mA	
x		206	207	Digital Out	1	N/A	UINT16	-	Digital output 1 is bit 0 and output 2 is bit 1.
x		207	208	Relays	1	N/A	UINT16	-	Relay 1 is bit 0 and relay 2 is bit 1.
Units									
x		250	251	Flow Units	1	N/A	UINT16	-	1 = l/s; 2 = m ³ /h; 3 = g/m
x		251	252	Pressure Units	1	N/A	UINT16	-	1 = bar; 2 = kPa; 3 = psi; 4 = ft; 5 = m
x		252	253	Power Units	1	N/A	UINT16	-	1 = kw; 2 = hp
x		253	254	Speed Units	1	N/A	UINT16	-	1 = RPM; 2 = %
x		254	255	Temperature Units	1	N/A	UINT16	-	1 = Degrees Celsius; 2 = Degrees Fahrenheit
Counters									
x		275	276	Total Pump Running Hours	2	N/A	UINT32	1 h	
x	x	277	278	Trip Pump Running Hours	2	N/A	UINT32	1 h	Writing 0 to this register resets the counter.
x		279	280	Total Controller Running Hours	2	N/A	UINT32	1 h	
x		281	282	Present Controller Running Hours	2	N/A	UINT32	1 h	The running hours since the controller was powered on.
x		283	284	Total Pump Running kWh Counter	2	N/A	UINT32	1 kWh	
x	x	285	286	Trip Pump Running kWh Counter	2	N/A	UINT32	1 kWh	Writing 0 to this register rests the counter.

FUNCTION CODE		START ADDRESS	MODBUS REGISTER	DESCRIPTION	# OF REGISTERS	CHANGE DURING OPERATION	DATA TYPE	UNIT	NOTES
READ	WRITE								
0x03	0x06								
Control Settings									
x		300	301	Control Mode	1	Yes	UINT16	-	1 = Parallel; 2 = Inputs; 3 = Remote; 4 = Constant Flow; 5 = Constant Pressure; 6 = Linear Pressure; 7 = Quadratic Pressure; 8 = Quad Pressure Maximum; 9 = Quad Pressure Minimum; 10 = Quadratic Pressure Max/Min
x	x	301	302	HOA State	1	Yes	UINT16	-	0 = Off; 1 = Hand; 2 = Auto
x	x	302	303	Active Parameters	1	Yes	UINT16	-	1 = standard; 2 = mode 1 (heating mode); 3 = mode 2 (cooling mode)
x	x	303	304	Minimum Speed Limit	1	Yes	UINT16	0.1	In RPM
x	x	304	305	Maximum Speed Limit	1	Yes	UINT16	1	In RPM.
x	x	305	306	Hand Mode Speed	1	Yes	UINT16	0.1	Units as configured on Pump Control Module.
x	x	306	307	BMS Set Speed	1	Yes	UINT16	0.1	Units as configured on Pump Control Module.
Alarms and Warnings									
x		400	401	Alarms	2	N/A	UINT32	-	Refer to Alarms Table for Bit Positions
x		402	403	Warnings	2	N/A	UINT32	-	Refer to warnings table for Bit Positions
	x	404	405	Acknowledge Warnings	2	Yes	UINT32	-	32-bit field corresponding to the warning field
Parameters									
x		500	501	Standard Mode - Zero Flow Head	2	Yes	UINT32	0.01	Value for standard active mode. Units as configured on Pump Control Module.
x		502	503	Standard Mode - Design Head	2	Yes	UINT32	0.01	Value for standard active mode. Units as configured on Pump Control Module.
x		504	505	Standard Mode - Design Flow	2	Yes	UINT32	0.01	Value for standard active mode. Units as configured on Pump Control Module.
x		506	507	Standard Mode - Minimum Flow	2	Yes	UINT32	0.01	Value for standard active mode. Units as configured on Pump Control Module.
x		508	509	Mode 1 - Zero Flow Head	2	Yes	UINT32	0.01	Value for active mode 1. Units as configured on Pump Control Module.
x		510	511	Mode 1 - Design Head	2	Yes	UINT32	0.01	Value for active mode 1. Units as configured on Pump Control Module.
x		512	513	Mode 1 - Design Flow	2	Yes	UINT32	0.01	Value for active mode 1. Units as configured on Pump Control Module.
x		514	515	Mode 1 - Minimum Flow	2	Yes	UINT32	0.01	Value for active mode 1. Units as configured on Pump Control Module.
x		516	517	Mode 2 - Zero Flow Head	2	Yes	UINT32	0.01	Value for active mode 2. Units as configured on Pump Control Module.
x		518	519	Mode 2 - Design Head	2	Yes	UINT32	0.01	Value for active mode 2. Units as configured on Pump Control Module.
x		520	521	Mode 2 - Design Flow	2	Yes	UINT32	0.01	Value for active mode 2. Units as configured on Pump Control Module.
x		522	523	Mode 2 - Minimum Flow	2	Yes	UINT32	0.01	Value for active mode 2. Units as configured on Pump Control Module.
Information									
x		900	901	Pump Name / Tag name	8	N/A	ASCII	-	The pump name as a series of ASCII characters.
x		908	909	Serial Number	7	N/A	ASCII	-	Serial No. of the Pump represented by ASCII characters
x		915	916	Firmware Version	1	N/A	UINT16	00.00	Divide the number by 100 to get the major. minor version of the DEPC.
x		916	917	Hardware Version	1	N/A	UINT16	-	The Pump Control Module hardware version.
x		917	918	Modbus Version	1	N/A	UINT16	-	Version of the Armstrong Modbus version

3.2 BACNET OBJECTS - VERSION 1 - FOR FIRMWARE V1.16 AND OLDER

OBJECT ID	OBJECT NAME	READ/WRITE	COMMENTS
Status			
AV:100	Actual Speed	Read	In RPM
AV:101	Actual speed	Read	In %
AV:102	Motor Power	Read	Unit as configured in Pump Control Module
AV:103	Motor Input Voltage	Read	In Volts
AV:104	Motor Input Current	Read	In Amps
AV:105	Sensorless Head	Read	Unit as configured in Pump Control Module
AV:106	Sensorless Flow	Read	Unit as configured in Pump Control Module
AV:107	Total Flow	Read	Used for Parallel sensorless mode
AV:108	Total Power	Read	Used for Parallel sensorless mode
AV:109	No. Of Running Pumps	Read	Used for Parallel sensorless mode
AV:110	Max Sensorless Flow	Read	Unit as configured in Pump Control Module
AV:111	Max Sensorless Head	Read	Unit as configured in Pump Control Module
BV:2	Run Status	Read	1 → pump is running
Counters			
AV:275	Total Pump Running Hours	Read	
AV:276	Trip Pump Running Hours	Read/Write	Writing 0 to this register resets the counter.
AV:277	Total Controller Running Hours	Read	
AV:278	Present Controller Running Hours	Read	The running hours since the controller was powered on.
AV:279	Total Pump Running kWh Counter	Read	
AV:280	Trip Pump Running kWh Counter	Read/Write	Writing 0 to this register resets the counter.
Control Settings			
AV:300	Control Mode	Read	1 = Parallel; 2 = Inputs; 3 = Remote; 4 = Constant Flow; 5 = Constant Pressure; 6 = Linear Pressure; 7 = Quadratic Pressure; 8 = Quadratic Pressure with Maximum Flow; 9 = Quadratic Pressure with Minimum Flow; 10 = Quadratic Pressure with Minimum and Maximum Flow
AV:301	HOA State	Read/Write	0 = OFF; 1 = Hand Mode; 2 = Auto
AV:302	Active Parameters	Read/Write	1 = standard; 2 = mode 1 (heating mode); 3 = mode 2 (cooling mode)
AV:303	Minimum Speed Limit	Read	in RPM
AV:304	Maximum Speed Limit	Read	in RPM
AV:305	Hand Mode Speed	Read/Write	Unit as configured in Pump Control Module.
AV:306	BMS Set Speed	Read/Write	Unit as configured in Pump Control Module.
Alarms and Warnings			
AV:400	Alarms	Read	Refer to Alarms Table for Bit Positions
AV:401	Warnings	Read	Refer to Warnings Table for Bit Positions
AV:402	Acknowledge Warnings	Write	32-bit field corresponding to the warning field
Parameters			
AV:500	Standard Mode - Zero Flow Head	Read	Value for standard active mode. Unit as configured in Pump Control Module
AV:501	Standard Mode - Design Head	Read	Value for standard active mode. Unit as configured in Pump Control Module
AV:502	Standard Mode - Design Flow	Read	Value for standard active mode. Unit as configured in Pump Control Module
AV:503	Standard Mode - Minimum Flow	Read	Value for standard active mode. Unit as configured in Pump Control Module
AV:504	Mode 1 - Zero Flow Head	Read	Value for active mode 1. Unit as configured in Pump Control Module
AV:505	Mode 1 - Design Head	Read	Value for active mode 1. Unit as configured in Pump Control Module
AV:506	Mode 1 - Design Flow	Read	Value for active mode 1. Unit as configured in Pump Control Module
AV:507	Mode 1 - Minimum Flow	Read	Value for active mode 1. Unit as configured in Pump Control Module
AV:508	Mode 2 - Zero Flow Head	Read	Value for active mode 2. Unit as configured in Pump Control Module
AV:509	Mode 2 - Design Head	Read	Value for active mode 2. Unit as configured in Pump Control Module
AV:510	Mode 2 - Design Flow	Read	Value for active mode 2. Unit as configured in Pump Control Module
AV:511	Mode 2 - Minimum Flow	Read	Value for active mode 2. Unit as configured in Pump Control Module

OBJECT ID	OBJECT NAME	READ/WRITE	COMMENTS
I/O			
AI:0	Analog In 1	Read	As configured in Pump Control Module
AI:1	Analog In 2	Read	As configured in Pump Control Module
AO:0	Analog Out 1	Read	As configured in Pump Control Module
BI:0	Digital In:1	Read	As configured in Pump Control Module
BI:1	Digital In:2	Read	As configured in Pump Control Module
BO:0	Digital Out:1	Read	As configured in Pump Control Module
BO:1	Digital Out:2	Read	As configured in Pump Control Module
BV:0	Relay 1	Read	As configured in Pump Control Module
BV:1	Relay 2	Read	As configured in Pump Control Module

3.3 MODBUS REGISTER MAP - VERSION 2 - FOR FIRMWARE V1.17 AND NEWER

FUNCTION CODE		START ADDRESS	MODBUS REGISTER	DESCRIPTION	# OF REGISTERS	CHANGE DURING OPERATION	DATA TYPE	UNIT	NOTES
READ	WRITE								
0x03	0x06								
Status									
x		100	101	Actual Speed	1	N/A	UINT16	1 RPM	The current speed of the vFD in RPM.
x		101	102	Actual Speed	1	N/A	UINT16	0.1 %	The current speed of the vFD in % of the nominal motor speed.
x		102	103	Motor Power	2	N/A	UINT32	0.01	Units as configured on Pump Control Module.
x		104	105	Motor Input Voltage	1	N/A	UINT16	0.1 V	Voltage delivered by the vSD to the motor.
x		105	106	Motor Input Current	2	N/A	UINT32	0.01 A	Current delivered by the vSD to the motor.
x		107	108	Sensorless Head	2	N/A	UINT32	0.01	Units as configured on Pump Control Module.
x		109	110	Sensorless Flow	2	N/A	UINT32	0.01	Units as configured on Pump Control Module.
x		111	112	Total Flow	2	N/A	UINT32	0.01	Used for Parallel sensorless mode
x		113	114	Total Power	2	N/A	UINT32	0.01	Used for Parallel sensorless mode
x		115	116	Number of Running Pumps	1	N/A	UINT16	-	Used for Parallel sensorless mode
x		116	117	Max Sensorless Flow	2	N/A	UINT32	0.01	Units as configured on Pump Control Module.
x		118	119	Max Sensorless Head	2	N/A	UINT32	0.01	Units as configured on Pump Control Module.
x		122	123	Status	1	N/A	UINT16	-	Bit:0 = pump run status (0=not rotating, 1=rotating)
I/O									
x		200	201	Digital In	1	N/A	UINT16	-	Digital input 1 is bit 0 and input 2 is bit 1.
x		201	202	Analog In 1	2	N/A	UINT32	0.01 V, 0.01 mA	Units as configured on Pump Control Module
x		203	204	Analog In 2	2	N/A	UINT32	0.01 V, 0.01 mA	Units as configured on Pump Control Module
x		205	206	Analog Out 1	1	N/A	UINT16	0.01 mA	
x		206	207	Digital Out	1	N/A	UINT16	-	Digital output 1 is bit 0 and output 2 is bit 1.
x		207	208	Relays	1	N/A	UINT16	-	Relay 1 is bit 0 and relay 2 is bit 1.
Units									
x		250	251	Flow Units	1	N/A	UINT16	-	1 = l/s; 2 = m ³ /h; 3 = g/m
x		251	252	Pressure Units	1	N/A	UINT16	-	1 = bar; 2 = kPa; 3 = psi; 4 = ft; 5 = m
x		252	253	Power Units	1	N/A	UINT16	-	1 = kw; 2 = hp
x		253	254	Speed Units	1	N/A	UINT16	-	1 = RPM; 2 = %
x		254	255	Temperature Units	1	N/A	UINT16	-	1 = Degrees Celsius; 2 = Degrees Fahrenheit

FUNCTION CODE		START ADDRESS	MODBUS REGISTER	DESCRIPTION	# OF REGISTERS	CHANGE DURING OPERATION	DATA TYPE	UNIT	NOTES
READ	WRITE								
0x03	0x06								
Counters									
x		275	276	Total Pump Running Hours	2	N/A	UINT32	1 h	
x	x	277	278	Trip Pump Running Hours	2	N/A	UINT32	1 h	Writing 0 to this register resets the counter.
x		279	280	Total Controller Running Hours	2	N/A	UINT32	1 h	
x		281	282	Present Controller Running Hours	2	N/A	UINT32	1 h	The running hours since the controller was powered on.
x		283	284	Total Pump Running kWh Counter	2	N/A	UINT32	1 kWh	
x	x	285	286	Trip Pump Running kWh Counter	2	N/A	UINT32	1 kWh	Writing 0 to this register resets the counter.
Control Settings									
x		300	301	Control Mode	1	Yes	UINT16	-	1 = Parallel; 2 = Inputs; 3 = Remote; 4 = Constant Flow; 5 = Constant Pressure; 6 = Linear Pressure; 7 = Quadratic Pressure; 8 = Quad Pressure Maximum; 9 = Quad Pressure Minimum; 10 = Quadratic Pressure Max/Min
x	x	301	302	HOA State	1	Yes	UINT16	-	0 = Off; 1 = Hand; 2 = Auto
x	x	302	303	Active Parameters	1	Yes	UINT16	-	1 = standard; 2 = mode 1 (heating mode); 3 = mode 2 (cooling mode)
x	x	303	304	Minimum Speed Limit	1	Yes	UINT16	1	In RPM
x	x	304	305	Maximum Speed Limit	1	Yes	UINT16	1	In RPM.
x	x	305	306	Hand Mode Speed	1	Yes	UINT16	0.1	Units as configured on Pump Control Module.
x	x	306	307	BMS Set Speed	1	Yes	UINT16	0.1	Units as configured on Pump Control Module.
x	x	308	309	Start/Stop	1	Yes	UINT16	-	0 = stop pump; 1 = start pump
Alarms and Warnings									
x		400	401	Alarms	2	N/A	UINT32	-	Refer to alarms table for bit positions.
x		402	403	Warnings	2	N/A	UINT32	-	Refer to warnings table for bit positions.
x	x	404	405	Acknowledge Warnings	2	Yes	UINT32	-	32-bit field corresponding to the warning field.
Parameters									
x		500	501	Standard Mode - Zero Flow Head	2	Yes	UINT32	0.01	Value for standard active mode. Units as configured on Pump Control Module.
x		502	503	Standard Mode - Design Head	2	Yes	UINT32	0.01	Value for standard active mode. Units as configured on Pump Control Module.
x		504	505	Standard Mode - Design Flow	2	Yes	UINT32	0.01	Value for standard active mode. Units as configured on Pump Control Module.
x		506	507	Standard Mode - Minimum Flow	2	Yes	UINT32	0.01	Value for standard active mode. Units as configured on Pump Control Module.
x		508	509	Mode 1 - Zero Flow Head	2	Yes	UINT32	0.01	Value for active mode 1. Units as configured on Pump Control Module.
x		510	511	Mode 1 - Design Head	2	Yes	UINT32	0.01	Value for active mode 1. Units as configured on Pump Control Module.
x		512	513	Mode 1 - Design Flow	2	Yes	UINT32	0.01	Value for active mode 1. Units as configured on Pump Control Module.
x		514	515	Mode 1 - Minimum Flow	2	Yes	UINT32	0.01	Value for active mode 1. Units as configured on Pump Control Module.
x		516	517	Mode 2 - Zero Flow Head	2	Yes	UINT32	0.01	Value for active mode 2. Units as configured on Pump Control Module.
x		518	519	Mode 2 - Design Head	2	Yes	UINT32	0.01	Value for active mode 2. Units as configured on Pump Control Module.
x		520	521	Mode 2 - Design Flow	2	Yes	UINT32	0.01	Value for active mode 2. Units as configured on Pump Control Module.
x		522	523	Mode 2 - Minimum Flow	2	Yes	UINT32	0.01	Value for active mode 2. Units as configured on Pump Control Module.
x	x	539	540	Control Setpoint	2	Yes	UINT32	0.01	Value and unit as configured on pump control mode (constant pressure or constant flow)

FUNCTION CODE		START ADDRESS	MODBUS REGISTER	DESCRIPTION	# OF REGISTERS	CHANGE DURING OPERATION	DATA TYPE	UNIT	NOTES
READ	WRITE								
0x03	0x06								
Information									
x		900	901	Pump Name / Tag name	8	N/A	ASCII	-	The pump name as a series of ASCII characters.
x		908	909	Serial Number	7	N/A	ASCII	-	Serial No. of the Pump represented by ASCII characters
x		915	916	Firmware Version	1	N/A	UINT16	00.00	Divide the number by 100 to get the major. minor version of the DEPC.
x		916	917	Hardware Version	1	N/A	UINT16	-	The Pump Control Module hardware version.
x		917	918	BMS Modbus Version	1	N/A	UINT16	-	Version of the Armstrong Modbus registers used.
x		918	919	Firmware Patch Version	1	N/A	UINT16	00	Patch version of the DEPC. To be appended to firmware version register.

3.4 BACNET OBJECTS - VERSION 2 - FOR FIRMWARE V1.17 AND NEWER

OBJECT ID	OBJECT NAME	READ/WRITE	COMMENTS
Status			
AV:100	Actual Speed	Read	In RPM
AV:101	Actual speed	Read	In %
AV:102	Motor Power	Read	Unit as configured in Pump Control Module
AV:103	Motor Input Voltage	Read	In Volts
AV:104	Motor Input Current	Read	In Amps
AV:105	Sensorless Head	Read	Unit as configured in Pump Control Module
AV:106	Sensorless Flow	Read	Unit as configured in Pump Control Module
AV:107	Total Flow	Read	Used for Parallel sensorless mode
AV:108	Total Power	Read	Used for Parallel sensorless mode
AV:109	No. Of Running Pumps	Read	Used for Parallel sensorless mode
AV:110	Max Sensorless Flow	Read	Unit as configured in Pump Control Module
AV:111	Max Sensorless Head	Read	Unit as configured in Pump Control Module
BV:2	Run Status	Read	1 → pump is running
Counters			
AV:275	Total Pump Running Hours	Read	
AV:276	Trip Pump Running Hours	Read/Write	Writing 0 to this register resets the counter.
AV:277	Total Controller Running Hours	Read	
AV:278	Present Controller Running Hours	Read	The running hours since the controller was powered on.
AV:279	Total Pump Running kWh Counter	Read	
AV:280	Trip Pump Running kWh Counter	Read/Write	Writing 0 to this register resets the counter.
Control Settings			
AV:300	Control Mode	Read	1 = Parallel; 2 = Inputs; 3 = Remote; 4 = Constant Flow; 5 = Constant Pressure; 6 = Linear Pressure; 7 = Quadratic Pressure; 8 = Quadratic Pressure with Maximum Flow; 9 = Quadratic Pressure with Minimum Flow; 10 = Quadratic Pressure with Minimum and Maximum Flow
AV:301	HOA State	Read/Write	0 = OFF; 1 = Hand Mode; 2 = Auto
AV:302	Active Parameters	Read/Write	1 = standard; 2 = mode 1 (heating mode); 3 = mode 2 (cooling mode)
AV:303	Minimum Speed Limit	Read	in RPM
AV:304	Maximum Speed Limit	Read	in RPM
AV:305	Hand Mode Speed	Read/Write	Unit as configured in Pump Control Module.
AV:306	BMS Set Speed	Read/Write	Unit as configured in Pump Control Module.
BV:14	Start/Stop	Read/Write	Start/stop of pump

OBJECT ID	OBJECT NAME	READ/WRITE	COMMENTS
Alarms and Warnings			
AV:400	Alarms	Read	Refer to Alarms Table for Bit Positions
AV:401	Warnings	Read	Refer to Warnings Table for Bit Positions
AV:402	Acknowledge Warnings	Read/Write	32-bit field corresponding to the warning field
Parameters			
AV:500	Standard Mode - Zero Flow Head	Read/Write	Value for standard active mode. Unit as configured in Pump Control Module
AV:501	Standard Mode - Design Head	Read/Write	Value for standard active mode. Unit as configured in Pump Control Module
AV:502	Standard Mode - Design Flow	Read/Write	Value for standard active mode. Unit as configured in Pump Control Module
AV:503	Standard Mode - Minimum Flow	Read/Write	Value for standard active mode. Unit as configured in Pump Control Module
AV:504	Mode 1 - Zero Flow Head	Read/Write	Value for active mode 1. Unit as configured in Pump Control Module
AV:505	Mode 1 - Design Head	Read/Write	Value for active mode 1. Unit as configured in Pump Control Module
AV:506	Mode 1 - Design Flow	Read/Write	Value for active mode 1. Unit as configured in Pump Control Module
AV:507	Mode 1 - Minimum Flow	Read/Write	Value for active mode 1. Unit as configured in Pump Control Module
AV:508	Mode 2 - Zero Flow Head	Read/Write	Value for active mode 2. Unit as configured in Pump Control Module
AV:509	Mode 2 - Design Head	Read/Write	Value for active mode 2. Unit as configured in Pump Control Module
AV:510	Mode 2 - Design Flow	Read/Write	Value for active mode 2. Unit as configured in Pump Control Module
AV:511	Mode 2 - Minimum Flow	Read/Write	Value for active mode 2. Unit as configured in Pump Control Module
AV:520	Control Setpoint	Read/Write	Value and unit as configured on pump control mode (constant pressure or constant flow)
Information			
AV:900	BMS BACnet Version	Read	Version of the Armstrong BACnet points used.
I/O			
AI:0	Analog In 1	Read	As configured in Pump Control Module
AI:1	Analog In 2	Read	As configured in Pump Control Module
AV:113	Analog Out 1	Read	As configured in Pump Control Module
BI:0	Digital In 1	Read	As configured in Pump Control Module
BI:1	Digital In 2	Read	As configured in Pump Control Module
BV:15	Digital Out 1	Read	As configured in Pump Control Module
BV:16	Digital Out 2	Read	As configured in Pump Control Module
BV:0	Relay 1	Read	As configured in Pump Control Module
BV:1	Relay 2	Read	As configured in Pump Control Module

4.0 OPERATION

4.1 START-UP CHECKLIST



Particular care must be taken to check the following before the pump is put into operation:

- A Pump primed?
- B Rotation **ok**?
- C Lubrication **ok**?
- D Pipe work properly supported?
- E Voltage supply **ok**?
- F Overload protection **ok**?
- G Is the system clean?
- H Is the area around the pump clean?

Warranty

Does not cover any damages to the equipment resulting from failure to observe the above precautions. Refer to Armstrong General Terms and Warranty sheet. Contact your local Armstrong representative for full information.

4.2 STARTING PUMP



Ensure that the pump turns freely by hand, or with some gentle mechanical help such as a strap or Allen key in coupling bolt.

Ensure that all protective guarding is securely fixed in position.

The pump must be fully primed on start up. Fill the pump casing with liquid and rotate the shaft by hand to remove any air trapped in the impeller. On split-coupled Design Envelope units any air trapped in the casing as the system is filled must be removed by the manual air vent in the seal flush line. **Ensure entrained air is removed from Design Envelope pumps, prior to starting, through the air vent on the seal flush line. Open vent until clear of air.**

Design Envelope close-coupled units are fitted with seal flush/vent lines piped to the pump suction area. When these units operate, residual air is drawn out of the pump towards the suction piping. energize the motor momentarily and check that the rotation corresponds with the directional arrow on the pump casing (clockwise when viewed from non-drive end of motor).

Start the pump with the discharge valve closed and the suction valve open, then gradually open the discharge valve when the motor is at operating speed. The discharge valve may be **cracked** or open slightly at start up to help eliminate trapped air.

When stopping the pump: Close the discharge valve and de-energize the motor.

Do not run the pump against a closed discharge valve at full speed for an extended period of time (a few minutes maximum.)

Should the pump be noisy or vibrate on start-up a common reason is overstated system head. Check this by calculating the pump operating head by deducting the suction pressure gauge value from the discharge gauge reading. Convert the result into the units of the pump head as stated on the pump nameplate and compare the values. The system designer or operator should be made aware of this soon as some adjustment may be required to the drive settings to make the pump suitable for the system as installed.



Check rotation arrow prior to operating the unit. The rotation of all Armstrong 4200H & 4280 Vertical In-Line units is clockwise when viewed from behind the motor (NDE).

IMPORTANT:



Do not run the pump for any length of time under very low flow conditions or with the discharge valve closed. To do so could cause the water in the casing to reach super heated steam conditions and will cause premature failure and could cause serious and dramatic damage to the pump and surrounding area.

4.2.1 AUTO FLOW BALANCING

Auto-Flow Balancing automatically determines the control curve between the design flow at the on-site system head, and the minimum (zero-flow) head that will typically be lowered (reset).

Often the actual system head is less than expected, and the pump will operate further to the right of the curve at a higher flow rate than it was designed for due to less system resistance. The Auto Flow Balancing function performs a scan of the sensorless map against the actual system to establish the actual head for the design flow. The minimum (zero-flow) head will be reset according to the actual head at the design flow - the factory default is 40% of the design head, but can be lowered further for more energy savings if all zones are still satisfied.

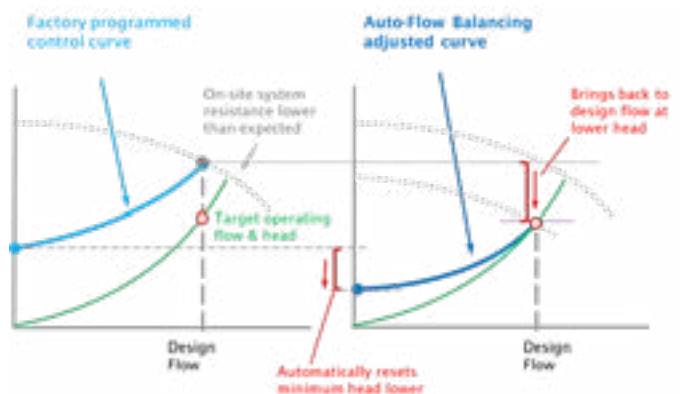

For buildings that are commissioned in multiple stages, or where the design flow changes each time, the Auto Flow Balancing function can be run at the beginning of each stage.

From the touch screen, go to **Pump Configuration -> Auto Flow Balancing**, then follow the on-screen instructions. The Auto Flow Balancing scan takes approximately 3 minutes to complete.



4.3 TOUCH SCREEN

4.3.1 LOGIN

Default Password 1234

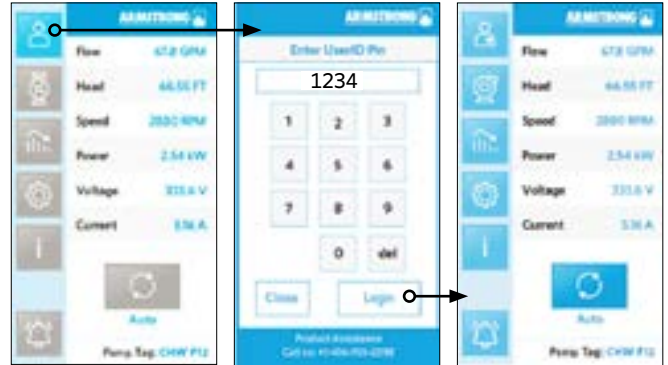

4.3.2 LOGOUT



4.3.3 ABOUT

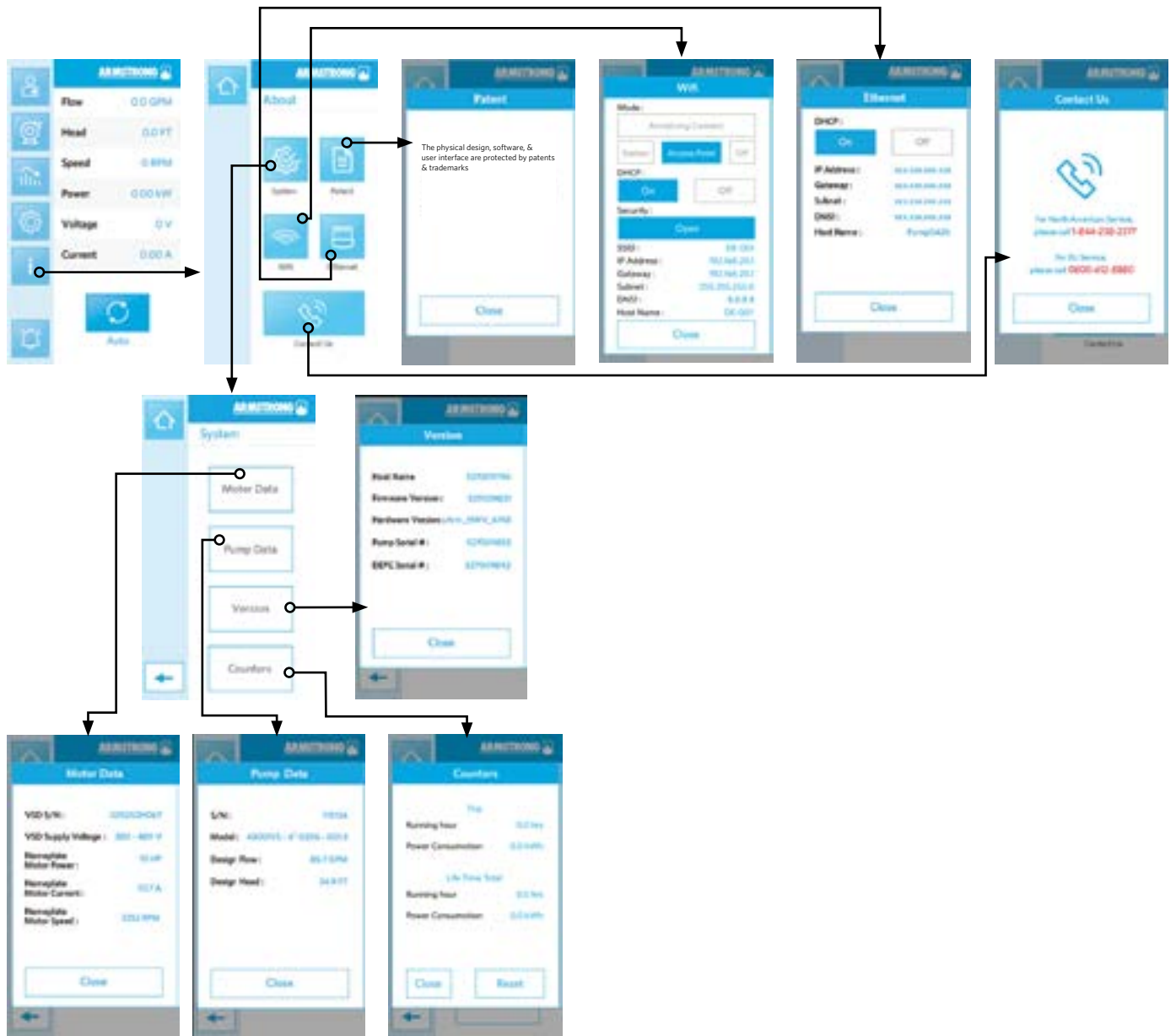

Click on **Reset** to reset Trip counters

4.3.4 GENERAL SETTINGS

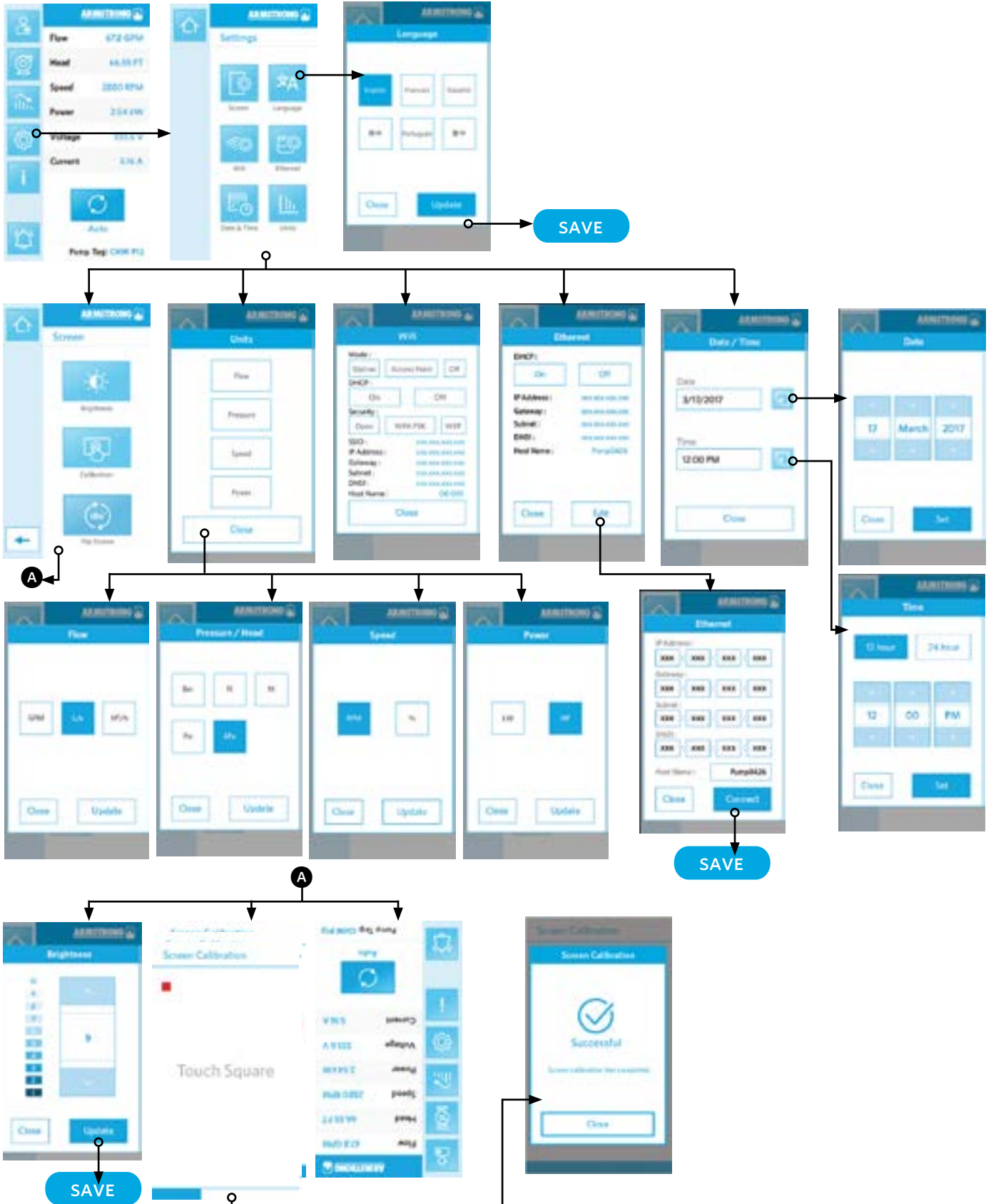

4.3.5 MANUAL/AUTO MODE

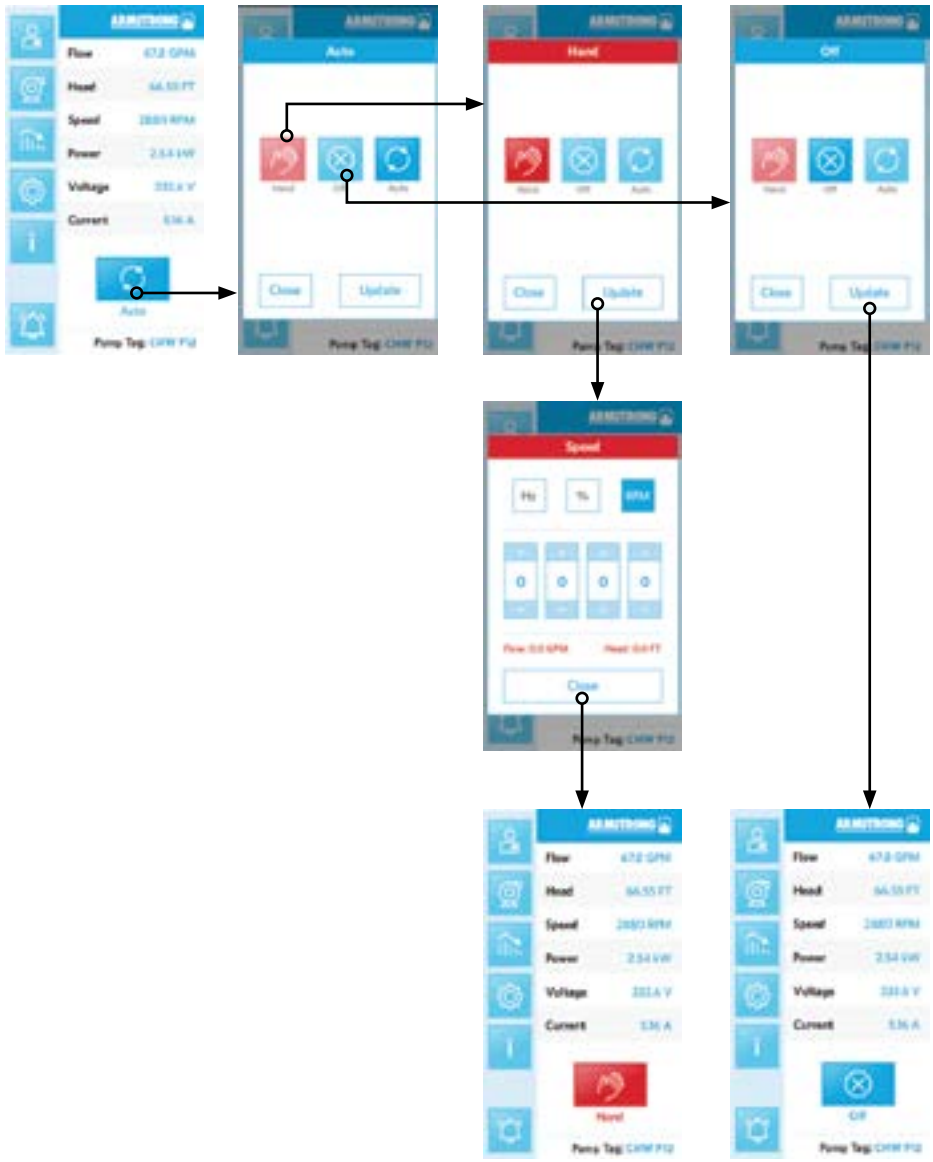

4.3.6 PUMP CONTROL



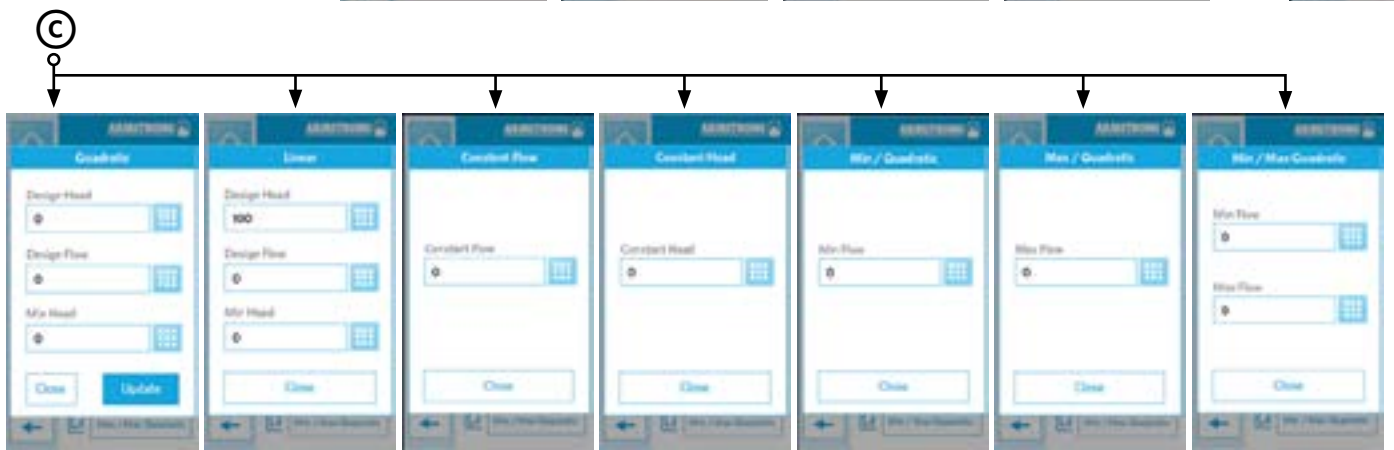
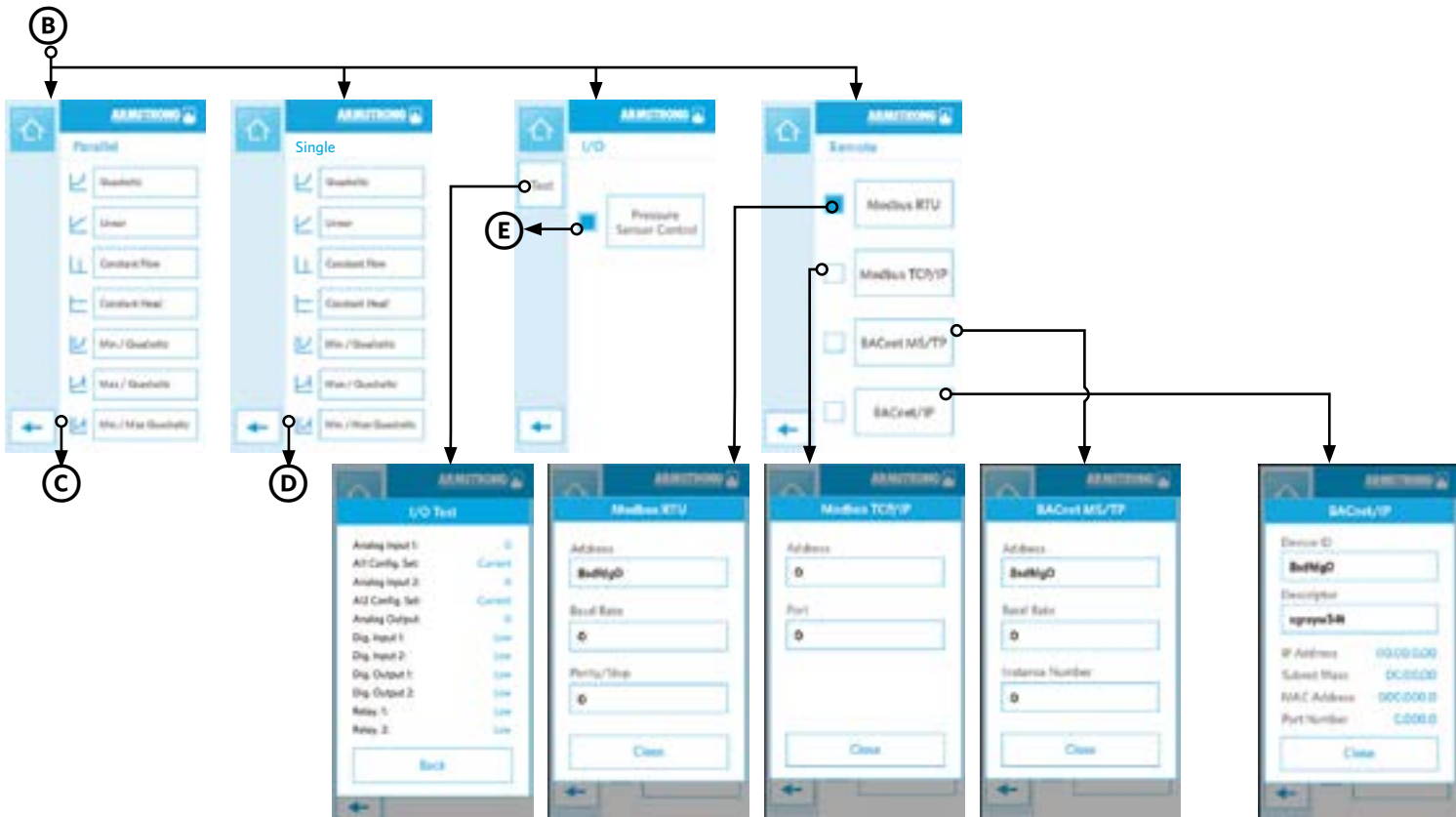

E

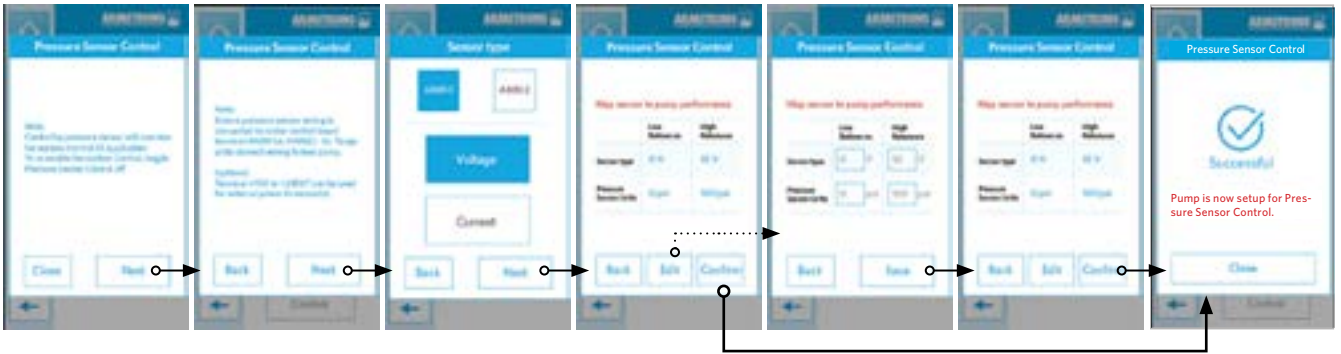

4.3.7 ALARMS & WARNINGS

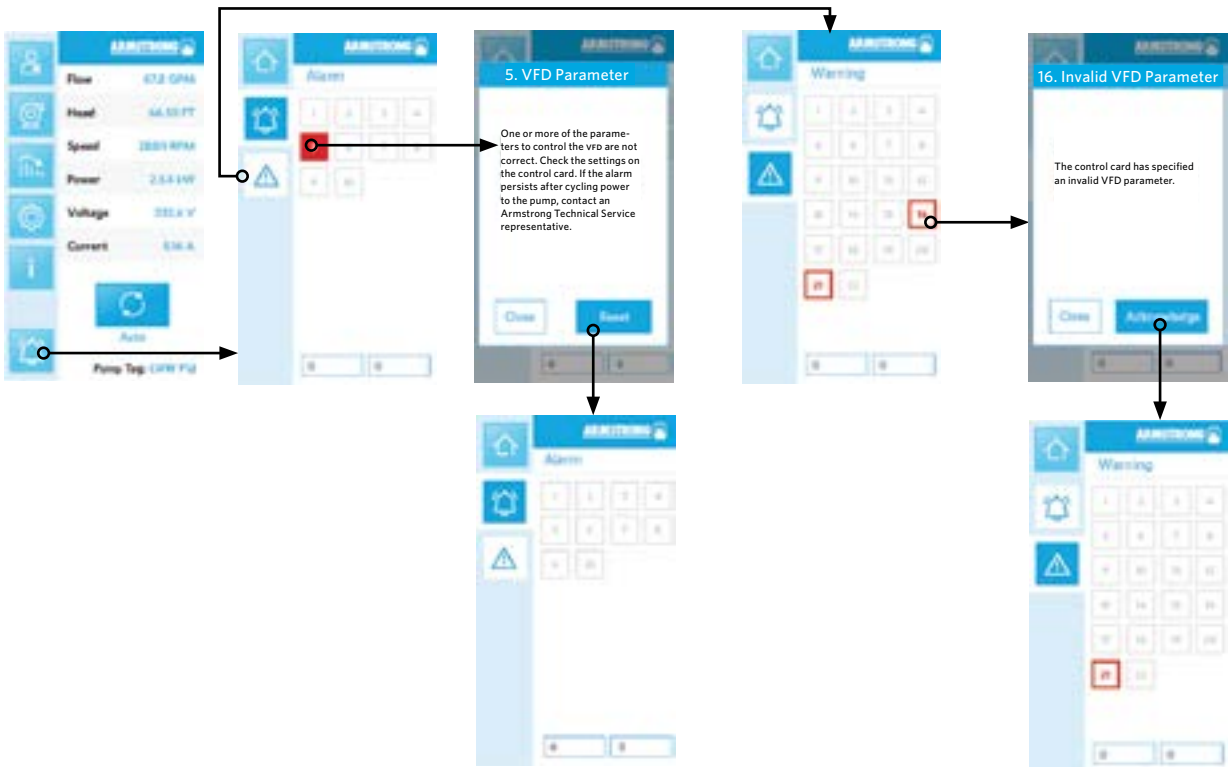

4.3.8 TREND-GRAPH

There are 3 parameters that can be trended on the touch screen interface:

- Power
- Flow
- Head

Which allows users to see a quick history of key performance data.



To see a more comprehensive view of the trends, the pump data can be exported in CSV format for review and analysis on a separate computing device.

4.3.9 BRIGHTNESS ADJUSTMENT

To adjust the brightness of the touch screen interface, go to **Settings -> Brightness**.

10 = highest brightness, 1 = lowest brightness



4.3.10 TOUCH SCREEN CALIBRATION

If you are having issues with the touch screen, including:

- Being unable to access items to the edge of the screen
- Some buttons from the display are unresponsive

The touch screen may require re-calibration. To calibrate the touch screen, go to **Settings -> Screen -> Calibration**

Follow the following 3-step calibration sequence (touching the squares) to reset the display coordinates.

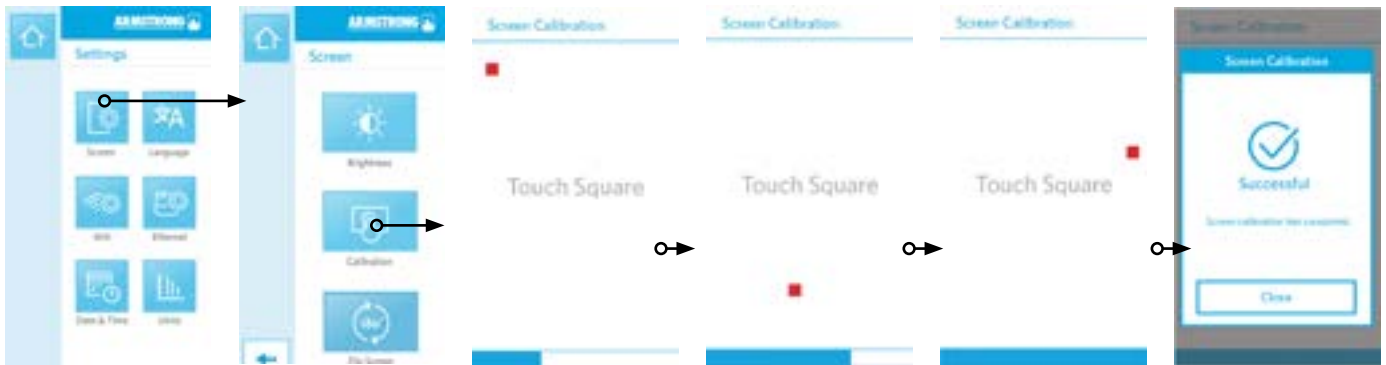

If you are unable to access the Calibration function from the touch screen itself, connect the pump to the webserver and go to **Settings -> General -> Recalibrate LCD Screen**. This will trigger the calibration sequence on the touch screen of the pump. Follow the above 3-step calibration sequence to reset the display coordinates.

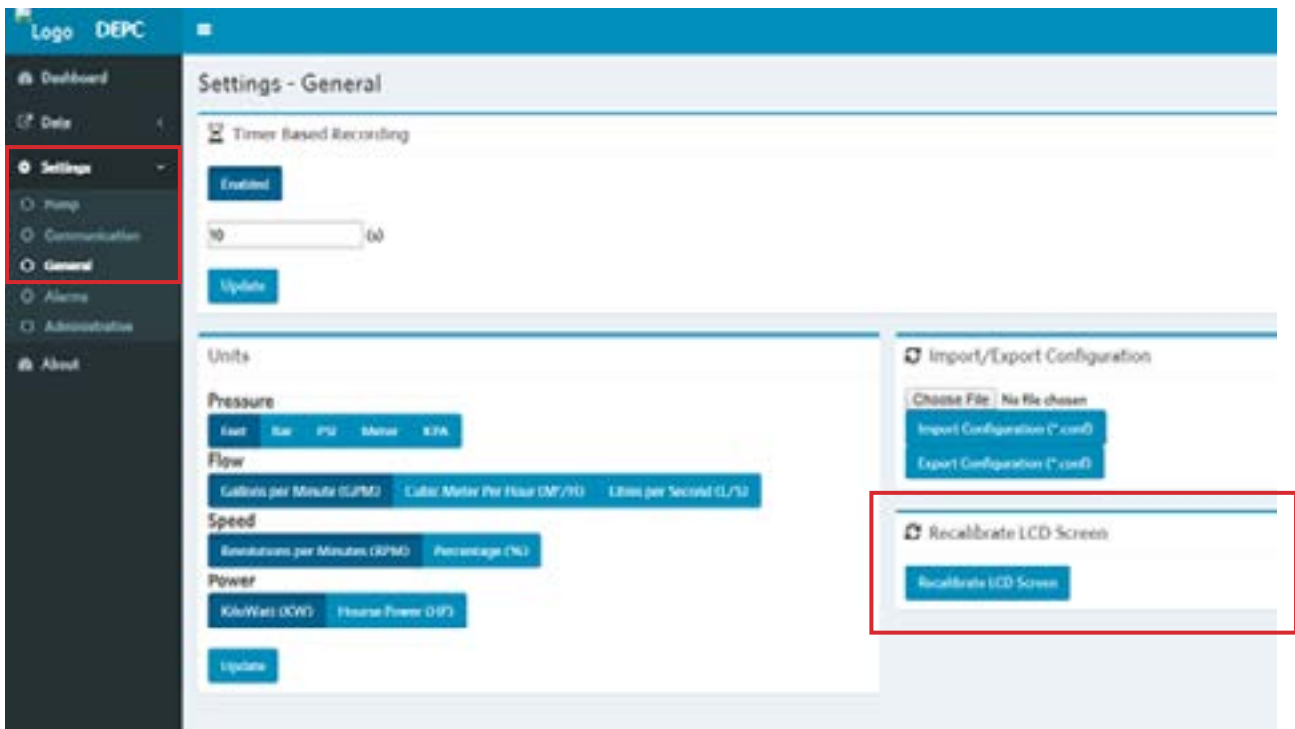

4.3.11 DATA LOGGING

Data logs can be used for energy performance analyses or to troubleshoot system issues. The data logs can be used with a building automation system (BAS) or for each standalone pump. Each pump controller logs the following data parameters over pre-defined time intervals (default is 5 minutes).

- Speed (rpm)
- Power (kW)
- Current (A)
- Flow (gpm)
- Head (ft)
- Analog Input 1
- Analog Input 2
- Analog Output
- Digital Input
- Digital Output
- Alarms
- Warnings
- kW-hours

The DEPC stores up to 3 months of data, at 5 min. intervals. More data storage is available on the cloud server if the pump is connected to the internet and has an active Pump Manager subscription.

Export Log File

The screenshot shows the 'Export Log File' interface. At the top, there are two input fields for date selection: 'Start date is: Wednesday, November 29, 2018' and 'End date is: Friday, November 30, 2018'. Below these are two calendar pickers for November 2018. The left calendar has the 29th selected, and the right calendar has the 30th selected. At the bottom left, there is a blue button labeled 'Export History' and a note that says 'History is in csv format.'

Connect the DEPC to the Webservice, in the **Data -> Trends -> Export Log File** section.

Select the start date, the end date, and then click **Export History** to download the data log file in CSV format.

4.4 WEB INTERFACE

Armstrong Strongly recommends to use Google Chrome browser to access DEPC web interface. Other browsers might be used but Google Chrome will guarantee the best operation.

4.4.1 CONNECTING VIA ETHERNET

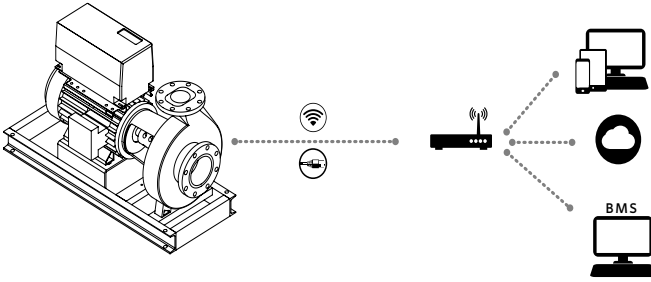

Connect your device to the router via wifi or by Ethernet cable.

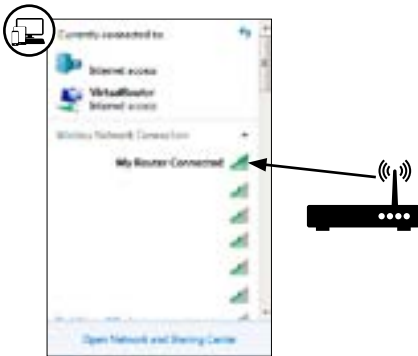

4.4.2 CONNECTING VIA WIFI

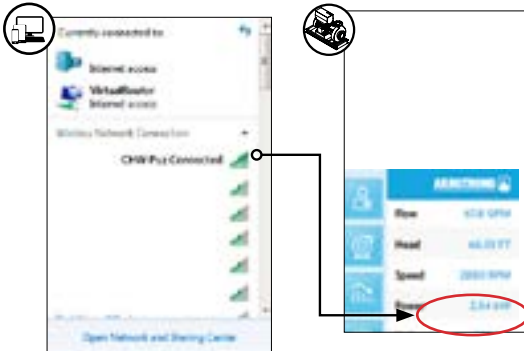

At the web browser address bar, type the Pump's IP (from Pump's About screen).

Default user level 1 Password: Armstrong1

Default user level 2 Password: Armstrong12



To access the control modes:

Press settings → Pump



Press settings → General, select desired units and click Update



To set the interval for timer based recording: Press settings → General, click on enable and input the desired time (default is 300 seconds)

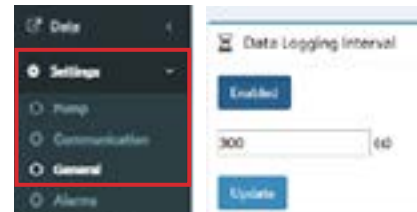

To Import/Export configuration files: Press Settings → General, select a file and click on **Import Configuration** to input. Click on Export Configuration to export

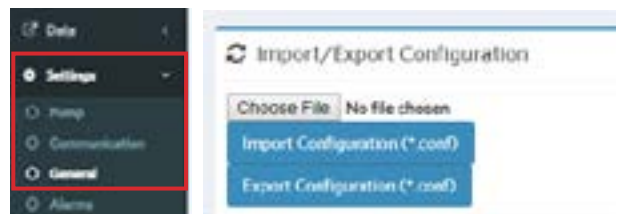

To modify Date/Time: click Settings → General and modify date and time



To access the control modes: Press settings → Pump

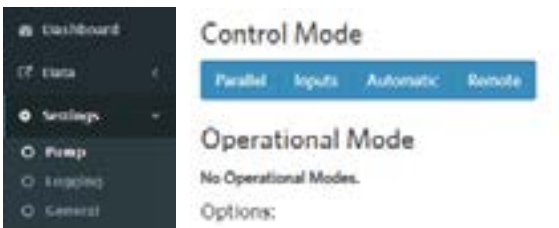

To select Version 1 or 2 of BMS settings, Click on Remote mode and select Version 1 or 2.



Settings → Pump,

To change motor ramp up and down settings, input in **Motor Ramp up Time** and **Motor Ramp Down Time**

To change Pump high and Low Speed, input RPM in **High Speed Limit** and **Low Speed Limit**

To change pump tag, input new tag in **Pump Tag**



To modify out settings: Settings → Pump,

To modify digital outputs: enable in Outputs and select desire,

To modify analog outputs: click enable and speed.

To modify relay settings: enable Relay functions and select desired settings



To enable Armstrong Connect: Settings → Communication, and click on Armstrong Connect to enable

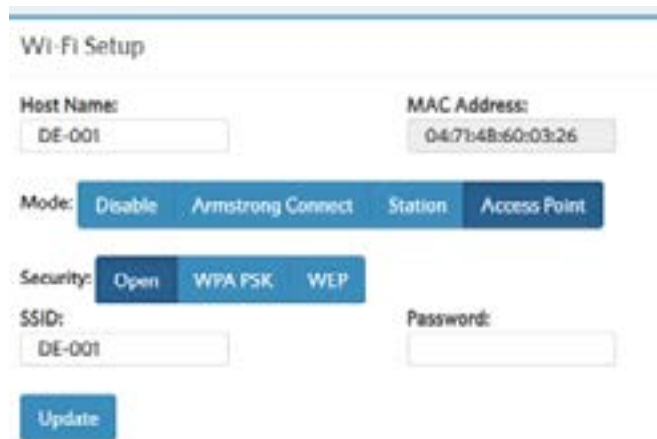

To set the BACnet max info from, Settings → Communication, enable BACnet Serial and input in **Max Info. Frame**



4.4.3 SWITCHING FREQUENCY

The IVS drive controls have an adjustable carrier frequency, or frequency at which the IGBTs are switched. The switching frequency affects the performance of the drive and motor and may produce an audible noise in some instances.

There are 2 pre-set modes available for the Switching Frequency.



High Efficiency Mode - 5kHz, (default)

This frequency setting minimizes the losses in the drive and motor for optimum performance. However, at this lower setting, the motor may produce an audible high-pitched noise. If noise is produced and unacceptable, then the drive can be set to Low Noise Mode.

Low Noise Mode - 12kHz

This frequency setting increases electrical losses, but are less audible. Set the controls to the Low Noise Mode if the High Efficiency Mode results in unacceptable audible noise.

4.5 DESIGN ENVELOPE FLOW READOUT TOLERANCE

Tolerance on flow and head readings between test stand instrumentation and Design Envelope controller readout will be within 5% of BEP flow & head values for all Design Envelope sensorless pump selections.

The same BEP flow & head tolerance values will be carried to the Design Envelope selection point for that model (Guarantee point, to ANSI 40.6 Hydraulic Institute Standard-See FIG. 4.5.1), as follows:

FIG. 4.5.1

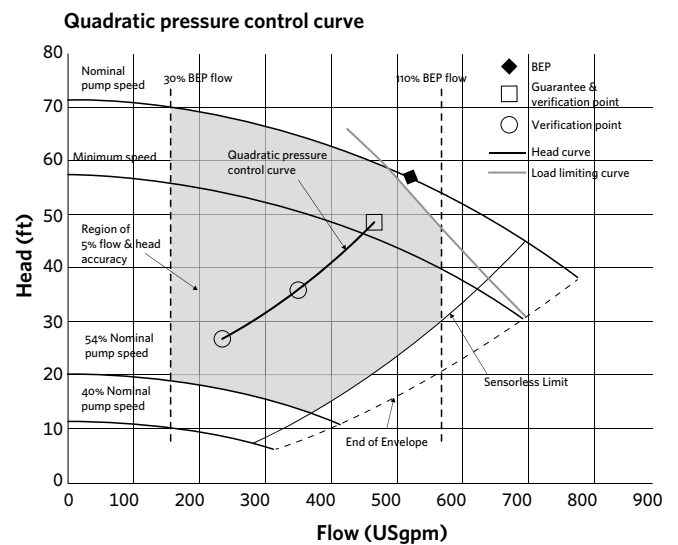

The tolerance is applicable when the flow is between 30% and 110% of BEP flow at Nominal Pump Speed; and the operating point is at 54% of Nominal Pump Speed, or greater; and the motor power is 2hp, or greater.

Flow readouts outside the above limits will be less accurate.

Nominal Pump Speed is displayed as the top speed on any Design Envelope pump curve.

5.0 CONTROL MODES

5.1 CONSTANT FLOW

Design Envelope pumps can be configured to maintain a constant pump flow in a system as the system head varies. This effectively simulates speed control by a flow meter in the piping.

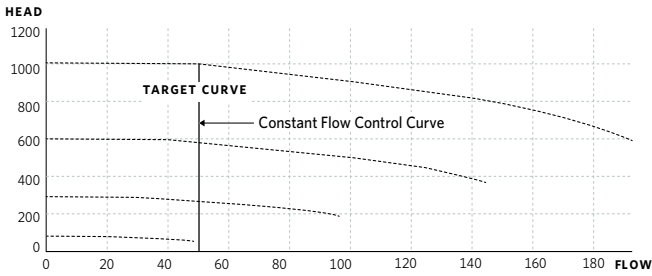

5.2 CONSTANT PRESSURE

Design Envelope pumps can be configured to maintain a constant pump head in a system as the demand varies. This effectively simulates the mounting of a differential pressure sensor at, or near, the pump.

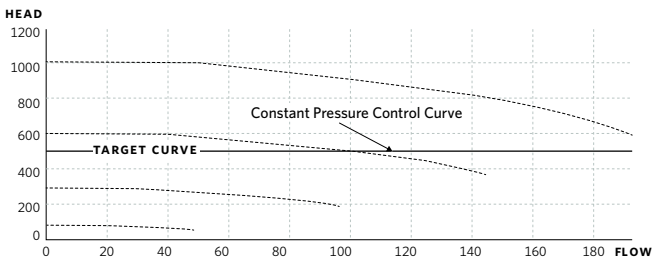

5.3 LINEAR PRESSURE

Linear Pressure Control is where the controller is set to control the speed according to a control 'curve' between max and min flow. This type of control will change the pump speed to ensure the pump operates on the projected linear control curve, where the pump head varies directly with the flow. This type of control is well known globally and is effective as far as the straight linear line will allow. For more realistic HVAC control with superior energy savings, consider the following control recommendation 5.4 Quadratic Curve Control.

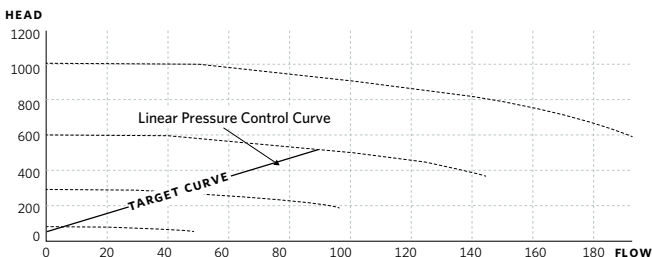

5.4 QUADRATIC CURVE CONTROL

Quadratic Pressure Control is where the controller is set to control the speed according to a control curve between max and min flow. It is widely recognized that fitting a differential pressure sensor at the most remote load, across the supply piping and return piping encompassing the valve and coil set, is the benchmark scheme for energy efficiency.

Design Envelope pumps can replicate this control without the need for the remote sensor. As the flow required by the system is reduced, the pump automatically reduces the head developed according to the pre-set control curve.

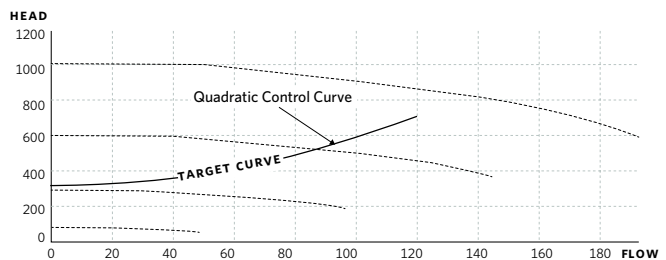

5.5 QUADRATIC CURVE CONTROL WITH MINIMUM FLOW PROTECTION

This configuration is designed for HVAC hydronic systems where flow sensitive equipment required a minimum flow for equipment stability; such as a chiller that cannot tolerate flow below a certain volume. This control will take advantage of the 5.4 Quadratic Curve Control mode, where the pump will increase speed to maintain a minimum flow setting as the system load is shutting down.

Pump controls can only control the flow to the maximum speed or motor limit;

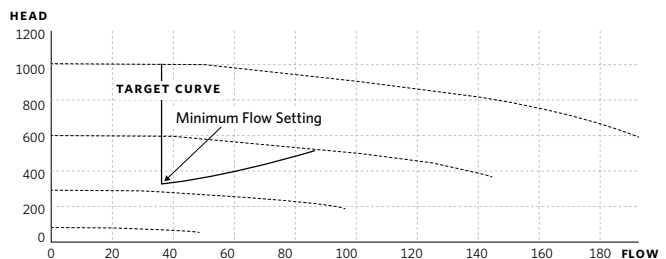

5.6 QUADRATIC CURVE CONTROL WITH MAXIMUM FLOW PROTECTION

This configuration is ideal for HVAC hydronic systems where pumps are generally oversized and a flow limit is required for system equipment stability and resulting energy savings. This control will take advantage of the 5.4 Quadratic Curve Control mode, where the pump will decrease speed to maintain a maximum flow setting. This will prevent over-pumping and save energy costs. Over-pumping is common in HVAC systems as pumps are typically oversized for the application.

Pump controls can only control the flow to a minimum speed; thus a dry-contact relay is supplies which will close when maximum flow is reached, which can be used for an alarm or other device.

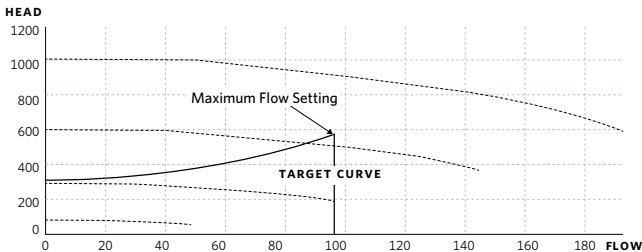

5.7 QUADRATIC CURVE CONTROL WITH MINIMUM & MAXIMUM FLOW PROTECTION

This control mode combines the control logic of 5.5 & 5.6 which takes the values of the quadratic control curve and protection for both the maximum & minimum flow limits. Pump controls can only control the flow to the motor limit or maximum / minimum speed limits of the unit, thus a dry-contact relay is supplies which will close when either the minimum or maximum flow is reached, which can be used for an alarm or other device.

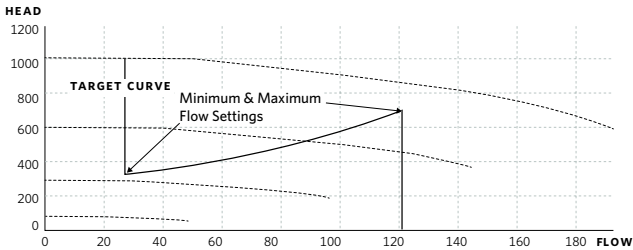

5.8 PARALLEL SENSORLESS PUMP CONTROL (PSPC)

This configuration maps the quadratic control curve into the pump controls and ensures the system flow requirements are met, while staging the pumps on and off to maintain optimum pump energy usage. This is accomplished by operating the pumping units at the best pumping efficiency level for the required flow.

This control is available for 2, 3, or 4 Design Envelope pump units operating in parallel. Tango and dualArm units have Parallel Sensorless Pump Control (PSPC) pre-programmed in the controls at Armstrong factories. For all other models (except twin pumps), PSPC can be enabled aftermarket; please contact your local Armstrong factory for details.

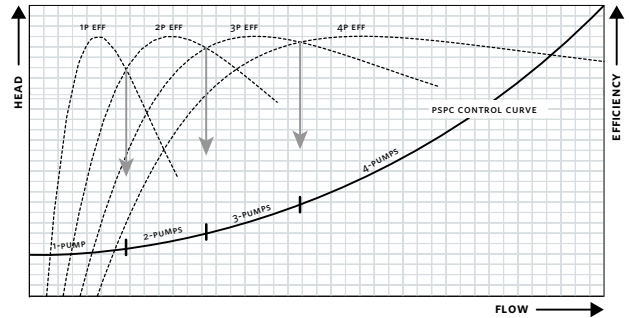

Both individual pumps and total parallel flow can be monitored by accessing **Settings -> Pump -> Control Mode -> Parallel Sensorless**



5.8.1 EMBEDDED PARALLEL SENSORLESS PUMP CONTROL FOR MULTIPLE PUMPS

If the Parallel Sensorless Pump Control option was purchased for control of 2, 3 or 4 single pumps (VILs and End Suctions) the function can be enabled at any time. Note that pumps must be of the same model for parallel operation.

Start by installing a wiring bridge between the pumps (supplied by others). The wiring between the control cards is a CANBUS (3-wire) cable with terminal blocks at each end (3 position strain 3.81 mm).

For connection of 3 or 4 pumps, the CANBUS connectors should be daisy-chained together.

Wiring bridge supplied by others.

For 2 pump parallel operation:

Ensure that both terminating resistor switches are set to Enabled (towards the **EN** label for the CANBUS port).

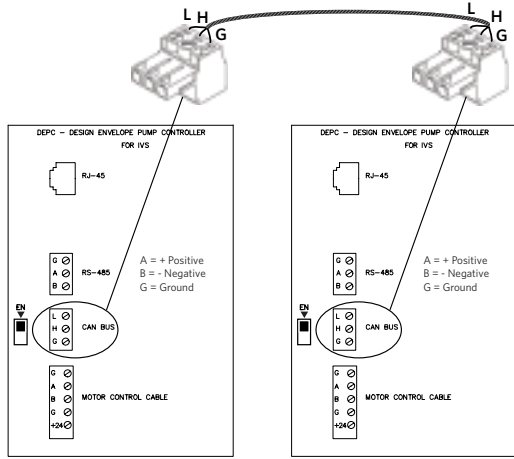

PUMP CONTROLLER 1 PUMP CONTROLLER 2

For 3 or 4 pump parallel operation:

Ensure that only the first and last terminating resistor switches are set to Enabled (towards the **EN** label for the CANBUS port).

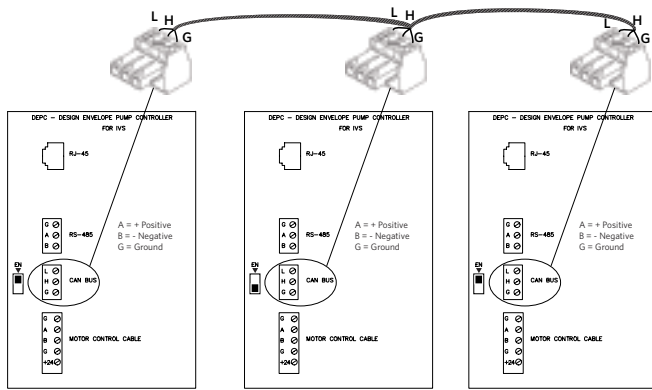

PUMP CONTROLLER 1 PUMP CONTROLLER 2 PUMP CONTROLLER 3

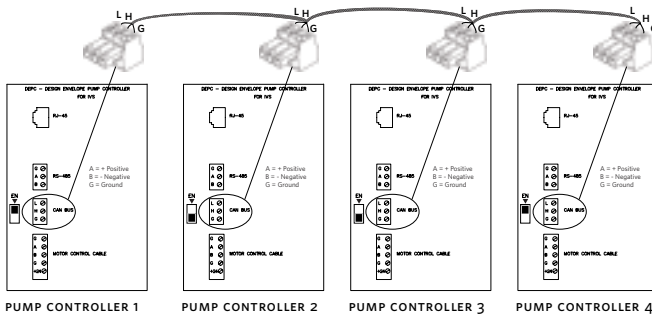

PUMP CONTROLLER 1 PUMP CONTROLLER 2 PUMP CONTROLLER 3 PUMP CONTROLLER 4

From the Webserver, choose Settings -> Pump, set control mode to Parallel with the following parameter values:



- Ⓐ ID: 1 to 255, the lower number is the lead pump e.g. enter 1 for lead pump, 2 for lag pump
- Ⓑ Dead Band: set to 0.25
- Ⓒ Total Design Flow: enter the parallel flow rate
- Ⓓ Sensorless Map Adjust Factor: set to 0.1
- Ⓔ Minimum On Time (seconds): set to 15

Click UPDATE to save all changes. Connect the Webserver to the second pump and then repeat above steps Ⓐ to Ⓔ.

5.8.2 MODIFYING MOTOR RAMP UP AND DOWN TIME

Modify the time in the respective fields after clicking on **Pump** under **Settings**

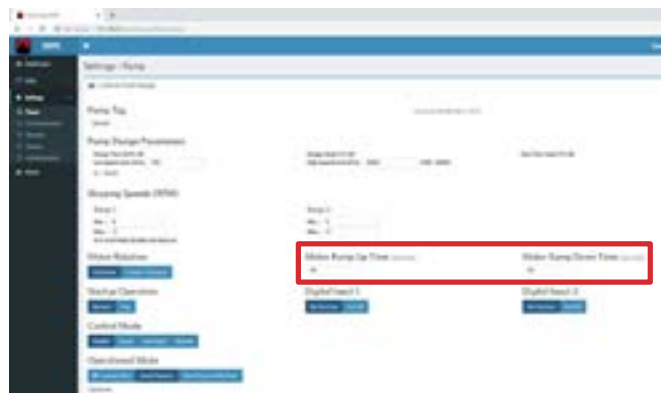

5.8.3 THREE DIFFERENT CONTROL MODES CAN BE ACCESSED

Constant Flow, Quadratic Pressure and Quadratic Pressure with Minimum Flow.



5.8.4 FALLBACK PERCENTAGE OF MAXIMUM SPEED

While operating multiple pumps in Parallel Sensorless mode, if any of the pumps are disconnected from the communication circuit (e.g. the pump is disconnected from the CANbus wire), the disconnected pump will now continue to operate at a pre-set constant speed - or the fallback speed. The fallback speed can be set to a percentage of the pump's maximum speed (between 40-100%).

Note that only the disconnected pump will operate at constant speed, the other remaining pumps in the communication circuit will continue to operate in Parallel Sensorless mode to the control curve.

This can be done in **Operational Mode** and input the **Fallback % of Max Speed**

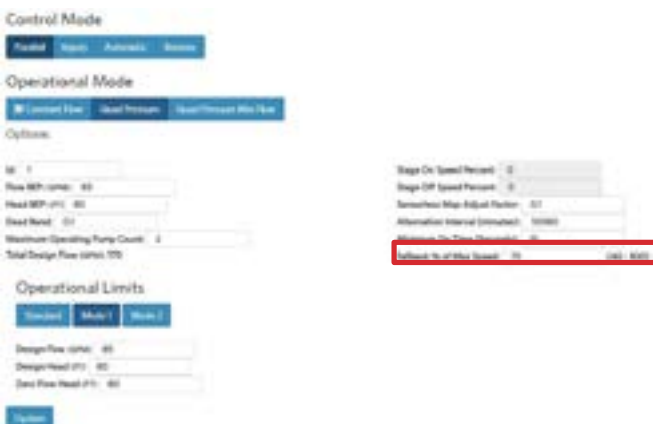

5.8.5 STANDBY PUMPS

Scroll down to **Operational Mode** and input the **Maximum Operating Pump Count**. The remaining pumps will be Standby. Calculated Design Flow will automatically update based on the number of pumps inputted.

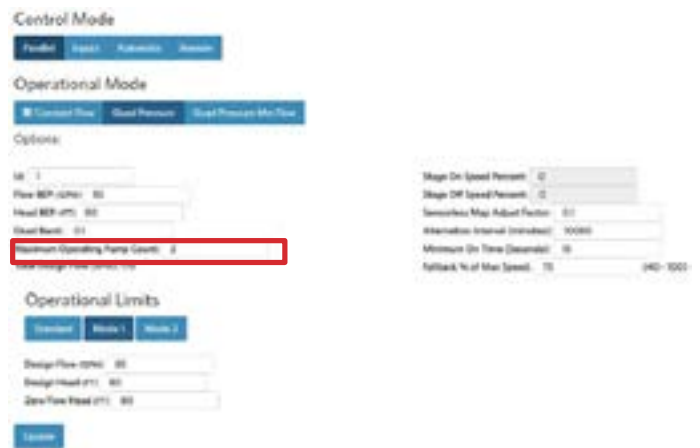

5.9 2*100% CAPACITY SPLIT UNITS

When duty / standby is specified, enter the total system flow into ACE Online or ADEPT, then select 2*100% unit split for a superior customer value. The 100% flow redundancy is still in place **plus** the onboard PSpC will engage the second unit in parallel operation should it predict lower operating costs.

If second side power is locked out, the operating pump will operate alone on the control curve to 100% design flow.

5.10 ALTERNATION

Design Envelope Tango, dualARM, and Twin units are pre-set to alternate lead-pump operation of each pump head to achieve equal run hours. The default alternation interval is 10,080 minutes (1 week). This can also be set or adjusted for multiple single pumps operating in sequence.

To change this setting, use the Webserver and go to Settings -> Pump, and then go the Control Mode section, under the Parallel tab, and input the Alternation Interval (in minutes) to the new value. Press UPDATE to complete the change. Connect the Webserver to the second pump and repeat.

Control Mode

Parallel Inputs Automatic Remote

Options:

Id: 1	Stage On Speed Percent: 0
Flow BEP: 85	Stage Off Speed Percent: 0
Head BEP: 80	Sensorless Map Adjust Factor: 0.1
Dead Band: 0.25	Alternation Interval (minutes): 10080
Total Design Flow: 171.4	Minimum On Time (Seconds): 15

5.11 CONSTANT PRESSURE CONTROL

Can be achieved if **Design Head** and **Zero Flow Head** are set to same value

Control Mode: Parallel Inputs Automatic Remote

Operational Mode: Constant Flow Dual Pressure Dual Pressure with Flow

Options:

Id: 1	Stage On Speed Percent: 0
Flow BEP (GPM): 85	Stage Off Speed Percent: 0
Head BEP (FT): 80	Sensorless Map Adjust Factor: 0.1
Dead Band: 0.25	Alternation Interval (minutes): 10080
Maximum Operating Pump Count: 2	Minimum On Time (Seconds): 15
Total Design Flow (GPM): 171.4	Fullback % of Max Speed: 75

Operational Limits:

Design Flow (GPM): 85

Design Head (FT): 80

Zero Flow Head (FT): 80

5.12 DUAL SEASON SETUP

Design Flow, Head and Zero Flow Head in Mode 1 and Mode 2 can be used as the two seasons of a Dual Season Setup

Operational Mode: Constant Flow Dual Pressure Dual Pressure with Flow

Options:

Id: 1	Stage On Speed Percent: 0
Flow BEP (GPM): 85	Stage Off Speed Percent: 0
Head BEP (FT): 80	Sensorless Map Adjust Factor: 0.1
Dead Band: 0.25	Alternation Interval (minutes): 10080
Maximum Operating Pump Count: 2	Minimum On Time (Seconds): 15
Total Design Flow (GPM): 171.4	Fullback % of Max Speed: 75

Operational Limits:

Design Flow (GPM): 85

Design Head (FT): 80

Zero Flow Head (FT): 80

5.13 SENSORED CONTROL

dP sensors can be added to a single pump or a parallel pumping system through either the LCD Screen on the Pump or the Webserver.

5.13.1 ADDING DP SENSORS THROUGH LCD SCREEN

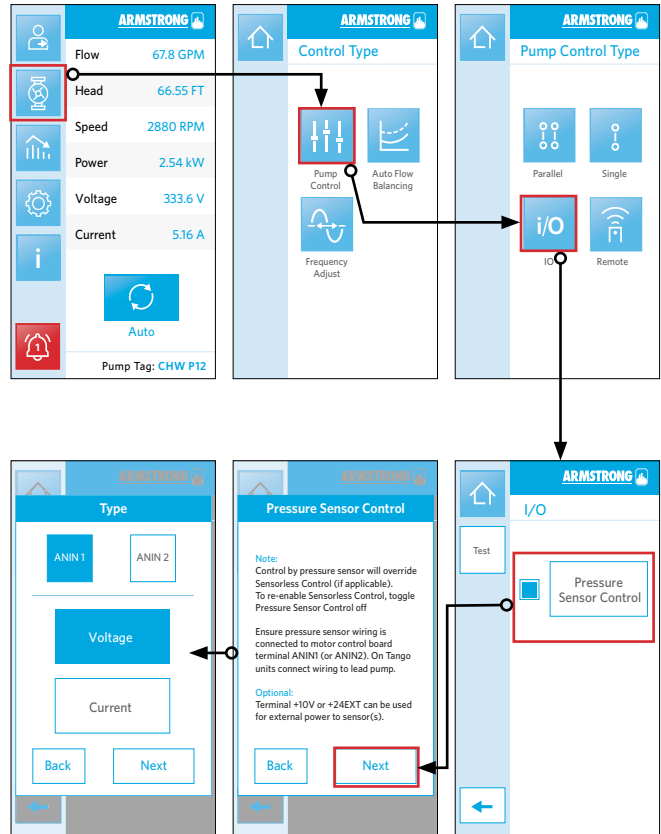

5.13.2 ADDING DP SENSORS FROM WEBSERVER

Scroll down to **Control Mode: Inputs**



5.14 BYPASS VALVE CONTROL

The bypass valve control is used to protect flow sensitive equipment (such as chillers). If the flow is less than Setpoint 1, the DEPC analog output sends 20mA to fully open the valve. If the flow is greater than Setpoint 2, the DEPC analog output sends 4mA to fully close the valve. There should be a sufficient gap between Setpoint 1 and 2 Flows to prevent the bypass valve from opening and closing unnecessarily. The recommended bypass valve is a modulating non-spring return valve (normally closed) with either 4-20mA analog input, or 2-10 Vdc analog input (requires adding 500ohm resistor across the valve input).

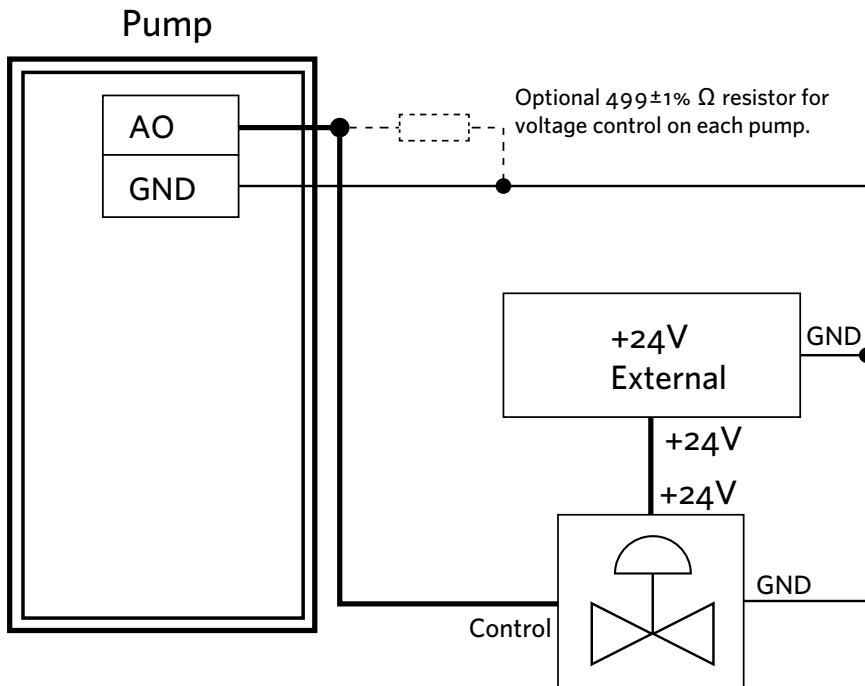
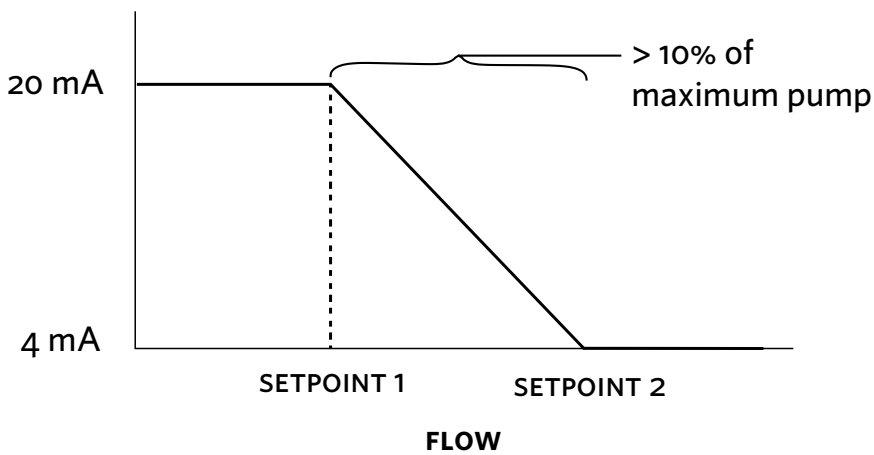

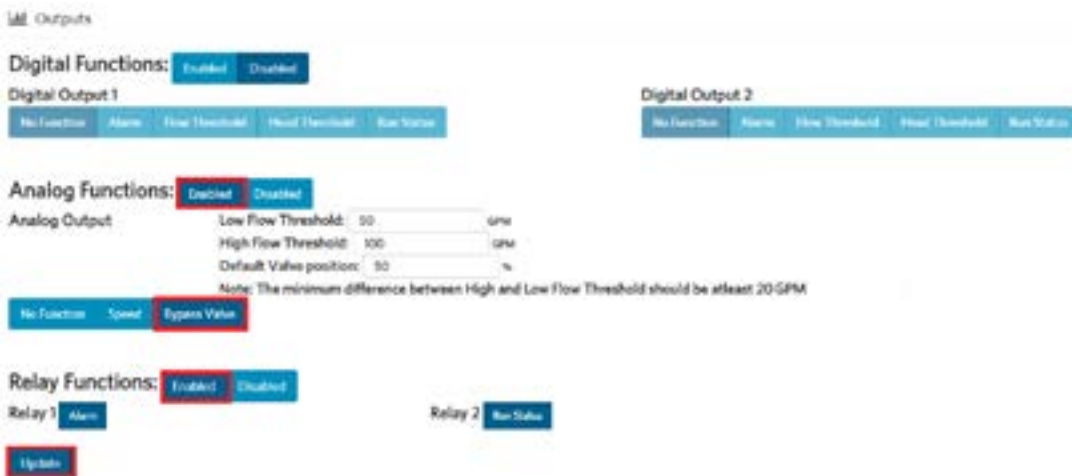
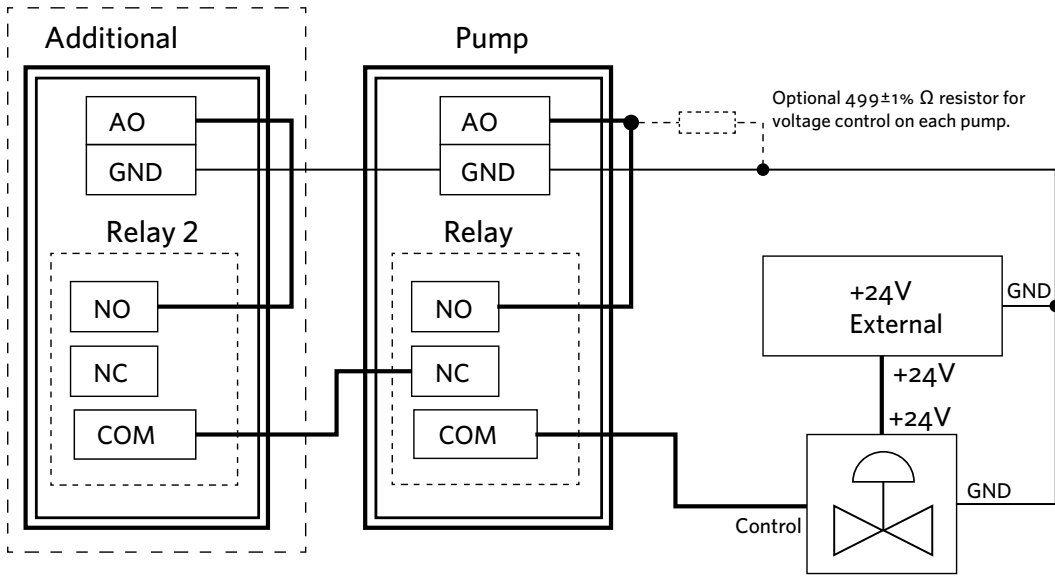

6.0 MAINTENANCE

6.1 GENERAL CARE

Vertical In-Line pumps are built to operate without periodic maintenance, other than motor lubrication on larger units. A systematic inspection made at regular intervals, will ensure years of trouble-free operation, giving special attention to the following:

- Keep unit clean
- Provide the motor with correctly sized overload protection. Keep moisture, refuse, dust or other loose particles away from the pump and ventilating openings of the motor.
- Avoid operating the unit in overheated surroundings (Above 100°F/40°C).

WARNING



Whenever any service work is to be performed on a pumping unit, disconnect the power source to the driver, lock it off and tag with the reason. Any possibility of the unit starting while being serviced must be eliminated. If mechanical seal environmental accessories are installed, ensure water is flowing through the sight flow indicator and that filter cartridges are replaced as recommended. (See Armstrong files 43.85 and 43.86 for seal environmental instructions).

6.2 LUBRICATION

Pump

Lubrication is not required. There are no bearings in the pump that need external lubrication service.

Motor

Follow the lubrication procedures recommended by the motor manufacturer. Many small and medium sized motors are permanently lubricated and need no added lubrication. Generally, if there are grease fittings evident the motor needs periodic lubrication. None if not.

Check the lubrication instructions supplied with the motor for the particular frame size indicated on the motor nameplate.

Warranty

Does not cover any damages to the equipment resulting from failure to observe the above precautions. Refer to Armstrong General Terms and Warranty sheet. Contact your local Armstrong representative for full information.

WARNING



Whenever any service work is to be performed on a pumping unit, disconnect the power source to the driver, lock it off and tag with the reason. Any possibility of the unit starting while being serviced must be eliminated. If mechanical seal environmental accessories are installed, ensure water is flowing through the sight flow indicator and that filter cartridges are replaced as recommended. (See Armstrong files 43.85 and 43.86 for seal environmental instructions).

WARNING



Hydronic system components may be pressurized which, if suddenly released, can cause serious injury or death. When performing any kind of service to the pump, the pressure must be released in the system and the unit should be properly drained before starting any service work.

6.3 MECHANICAL SEAL

6.3.1 MECHANICAL SEAL REPLACEMENT INSTRUCTIONS FOR 4200H SPLIT COUPLED VERTICAL IN-LINE PUMP

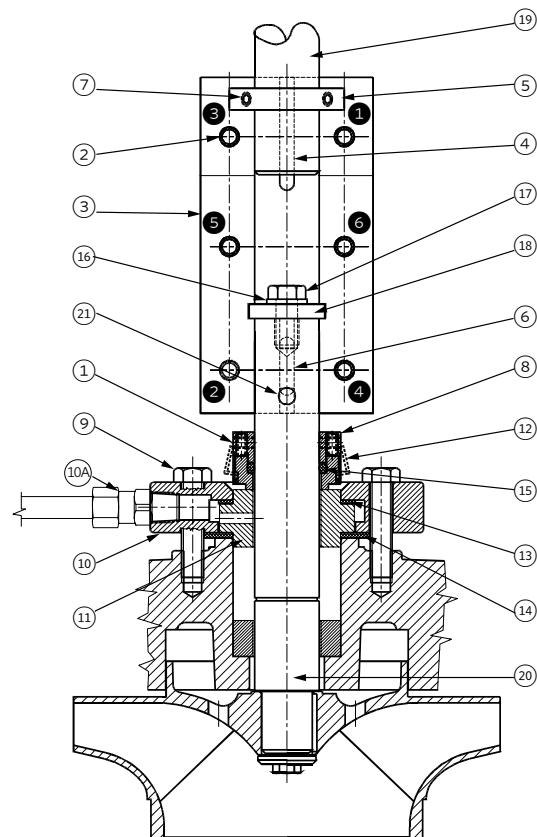

CAUTION



Do not use oil, Vaseline or other petroleum or silicon based products for seal elastomer lubrication. Otherwise elastomer swelling may occur, causing seal failure. Recommended: International Products

Corp P-80 Rubber Lubricant Emulsion in USA & UK www.ipcol.com

CAUTION



The permissible TDS levels are :

A SSiC Vs C - 2000ppm max

B SSiC Vs SSiC - 4000ppm max

In case the water exceeds permissible TDS levels, corrosion or fouling may occur resulting in seal failures. It is necessary to maintain the water quality with proper water treatment program.

Seal Removal

An important feature of the Design Envelope 4200H pump is that the design permits removal of the mechanical seal without disturbing the pump, motor or electrical wiring.

- A** Disconnect the power supply at the main switch and close the isolating valves on the suction and discharge. Empty casing by removing drain plug(s) located at the bottom.
- B** Loosen off the seal collar set screws (1) Remove the coupling screws (2) and separate the coupling halves (3). Remove the motor shaft key (4) and the pump shaft key (6). **Do not remove motor collar (5) for seal replacement.** Use Allan wrench and insert coupling screw into positioning hole (21) to prevent shaft rotation and remove the capscrew, lockwasher and collar (17, 16, & 18) from the pump shaft.
- C** Remove the mechanical seal rotating assembly (8) through the gap between the pump and motor shafts.
- D** Disconnect the seal flush piping (10A). Mark seal plate (10) position. Remove the seal plate bolts (9) and seal plate (10). Remove the stationary seat (11) and seat gaskets (13 & 14).

Seal Replacement

Handle mechanical seal carefully to protect seal faces from damage. Do not contaminate seal faces with finger prints.

- E** Replace the stationary seat (11) and gaskets (13 & 14), aligning the seat flush hole with the seal plate flush line connection. Ensure the large diameter gasket (14) is on the bottom. Replace seal plate (10) and tighten the seal plate bolts (9) evenly and diagonally, to the following torque (ft. lbs) values: 1.125" seal - 20; 1.625"/2.125"/2.625" (7.5" diameter plate) - 50; 2.625 (9" diameter) - 90.

- F** When installing the mechanical seal (8), ensure parts are perfectly clean.
- G** Apply a small amount of temporary rubber lubricant emulsion to the o-ring (15). Carefully slide the mechanical seal rotating assembly (8) down the shaft onto the stationary seat (11). Do not tighten the set screws (1) on the side of the mechanical seal yet. Do not remove holding clips (12).

If motor is replaced: Loosen set screws (7) on motor shaft collar (5) and remove from old motor shaft. To position the collar (5) correctly on the new motor shaft, temporarily fit motor shaft collar (5) into groove of the keyed coupling half. Slide collar, with coupling half onto new motor shaft until end of shaft lines up with line scored into coupling. Tighten the visible set screws (7) in the collar (5) enough to hold the collar in place on the shaft and remove the coupling half. Tighten all collar set screws (7) evenly and diagonally. Order replacement motors with locked lower bearing.

- H** Use Allan wrench and insert the coupling screw into positioning hole (21) to prevent pump shaft rotation and replace collar, lockwasher, and capscrew (18, 16, & 17). Cap-screw (17) must be firmly tightened on the pump shaft with a wrench.
- I** Fit the motor shaft key (4) and the pump shaft key (6) then install the keyed coupling half (3) first.

NOTE:

For easier coupling installation, motor and pump shaft keys (4 & 6) should be 180 degrees from the working area. To automatically locate the impeller in the pump, insert the coupling screw Allan wrench into positioning hole (21) and lift pump shaft until the pump shaft collar is positioned in the coupling groove, then rotate shaft to locate the pump shaft key (6) into blind keyway in coupling. Should the pump rotating assembly prove too heavy to lift easily: a piece of 2" x 4" wood may be firmly positioned to allow a pry-bar to be placed securely under the pump shaft collar; the rotating assembly may be levered and raised-up in that manner.

- J** Place the second coupling half into position and tighten the coupling screws (2) following the tightening pattern shown on the illustration(① ② ③ ④ ⑤ ⑥).

NOTE:

Snug fit the coupling screws and confirm even gap spacing between coupling halves, then firmly tighten coupling screws following the tightening pattern illustrated. Then push (or slide) mechanical seal (8) firmly onto the stationary seat (11) and tighten the set screws (1) to the following torque (ft. lbs) values: Seal sizes 1.125" to 2.625" - 5. Remove the holding clips (12) for operation. The mechanical seal is now preset at the correct working length.

- k Replace the seal flush piping (10A) and drain plug(s). Open all isolating valves prior to operating pump(s). Reconnect power supply.

6.3.2 MECHANICAL SEAL REPLACEMENT INSTRUCTIONS FOR 4280 CLOSE COUPLED VERTICAL IN-LINE PUMP

Refer to appropriate service work instructions (swi) file for breakdown instructions for the pump being serviced. Mechanical seal replacement instructions are included in the pump swi. The following instructions are included for convenience.

CAUTION



Always disconnect power supply from motor before beginning service work.

Seal Kit Installation Instructions

- 1 Remove impeller and mechanical seal from pump or motor shaft. The mechanical seal spring and spring holder usually comes free with the impeller. The mechanical seal rotating element must be pried loose with pry bars or screwdrivers. Once loosened, the seal may be pulled free of the shaft.
- 2 When removing the impeller and seal from a motor shaft, take care to retrieve the spacer from between the impeller and shaft sleeve. Store for later use.
- 3 The o-ring or L-cup mounted mechanical seal seat must be pried loose from the recess in the adapter. To do this: Separate the adapter from the bearing housing or motor. A screwdriver may then be used to push the seal seat out of the adapter from the rear.
- 4 Clean the shaft sleeve surface, ensuring the entire former seal elastomeric residue has been removed. Inspect for damage and replace if necessary. (See separate instructions, File No. 6042.25, for removal of the motor shaft sleeve). Inspect the water slinger and replace if damaged.
- 5 Silicon carbide is a suitable replacement for ceramic, ni-resist, or tungsten carbide and is the seal seat of choice. Ceramic and silicon carbide are more brittle than ni-resist or tungsten carbide and should be handled accordingly.
- 6 Install a new seal seat in the adapter cavity, being sure the lapped (polished) surface of the insert is facing up. Ensure that the cavity has been thoroughly cleaned. Lubricate the outside of the seat elastomer o-ring or L-cup with a small amount of temporary rubber lubricant emulsion and press down, straight and even, into the cavity. Do not press the seat in with bare fingers; use a clean cloth or the cardboard disc typically supplied with the seal. Contamination of the polished and lapped seat face could cause immediate leakage.

- 7 Replace the adapter, taking care that the seal seat is carefully guided over the shaft.

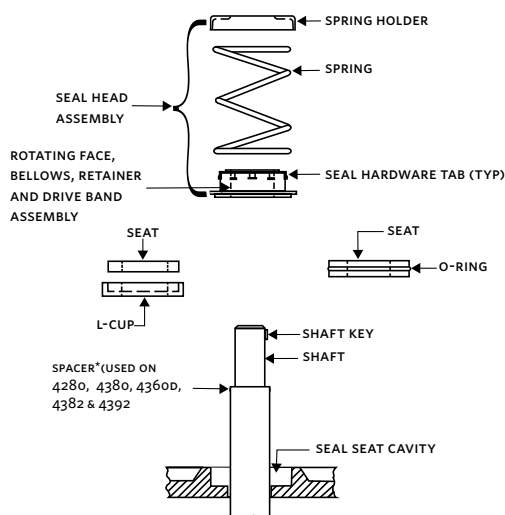

***IMPORTANT:** Spacer may come off when old seal kit is removed. Be sure it is on when installing new seal kit.

CAUTION



Do not use oil, Vaseline or other petroleum or silicon based products for seal elastomer lubrication. Otherwise elastomer swelling may occur, causing seal failure. Recommended: International Products Corp P-80 Rubber Lubricant Emulsion in USA & UK www.ipcol.com

- 8 Lubricate the inside of the seal rotating assembly (The 'rubber' bellows) with a small amount of temporary rubber lubricant emulsion and slide onto the shaft sleeve with a twisting motion, carbon face first, until pressed to the carbon face. Ensure the seal is securely in place by pushing firmly with 2 screw drivers simultaneously on opposite tabs of the seal hardware. Push the rotating seal retainer and seal hardware tabs simultaneously to ensure the elastomer is not over-stretched.
- 9 Remove the spring retainer from the seal spring and place the seal spring over the seal rotating assembly. Re-install the shaft sleeve spacer, if appropriate, and impeller key on the shaft and place the seal spring retainer onto the impeller hub register. Slide the impeller into place on the shaft, taking care and ensuring the seal spring is kept in place on the seal rotating assembly and fits well into the retainer on the impeller hub. Secure impeller and finish reassembling pump.

SEAL KIT PART NUMBER	S - 1.25"	975000-982	9975001-813	9975001-817	975000-982
	M - 1.625"	975000-984	9975001-833	9975001-837	975000-984
	L - 2.125"	975000-985	9975001-873	9975001-877	975000-985
Fluid type	Standard seal		All glycols > 30% WT CONC '(2000 ppm)' tafter 'WT CONC'	Potable (Drinking) Water	
Temperature	to 200°F/93°C	over 250°F/121°C	to 200°F/93°C	to 200°F/93°C	
Rotating face	Resin bonded carbon	Antimony loaded carbon	Sintered silicone carbide	Resin bonded carbon	
Seat elastomer	EPDM (L-CUP)	EPDM (O-ring)	EPDM (L-CUP)	EPDM (L-CUP)	
Material code	C-SSC L EPSS 2A	ACSSC O EPSS 2A	SSCSC L EPSS 2A	C-SSC L EPSS 2A	

Used on: 4280

Seal Type: 2A

Pump Construction: BF/AB/AI

Stationary face: Sintered silicone carbide

Secondary Seal: EPDM

Spring: Stainless steel

Rotating Hardware: Stainless steel

Notes:

- 1 Seal kit consists of rotating seal head, spring and holder, stationary seal seat with O-ring or L-cup. Pump casing gasket and other minor hardware components possibly required to reassemble the pump are not included. Consult service parts bulletins for more detail.
- 2 O-ring and L-cup style seats are interchangeable between centerline discharge pumps. Both styles are used as standard for inside seals after October 2011.
- 3 O-ring and L-cup style seats are not interchangeable between centerline and legacy tangential discharge pumps.

7.0 WARNINGS AND ALARMS

7.1 ALARM SUMMARY FOR INTERFACES

ALARM NUMBER	NAME	ALARM DESCRIPTION
1	VSD over temperature	The temperature of a vsd or motor component is exceeding the thermal alarm limit. Turn off the power to the pump and verify that the motor, fan and vsd cooling is functioning correctly. Verify that the pump is not overloaded. Wait until hot components have cooled before returning to service and if the alarm persists after powering up contact an Armstrong Technical Service representative.
2	VSD over current	The vsd has detected current exceeding the safe limit. Turn the pump off. (If there is a discharge from the output phases to earth it can be verified by checking for any faults with a megohmmeter between ground and the motor leads). If a current limit has been exceeded in the vsd check that the motor can be turned. If the pump is being overloaded reduce the pump speed using hand mode control. If the alarm persists after powering up contact an Armstrong Technical Service representative.
3	External vsd voltage	The voltage into the vsd is out of range. Verify that the correct voltage required to operate the vsd is present by measuring each of the 3 phases. If the alarm persists after cycling power to the pump, contact an Armstrong Technical Service representative.
4	Internal vsd voltage	An internal voltage generated by vsd is out of range. If the alarm persists after cycling power to the pump, contact an Armstrong Technical Service representative.
5	Internal vsd	An internal error in the vsd has occurred. If the alarm persists after cycling power to the pump, contact an Armstrong Technical Service representative.
6	VSD parameter	One or more of the parameters to control the vsd are not correct. Check the settings on the control card. If the alarm persists after cycling power to the pump, contact an Armstrong Technical Service representative.
7	VSD startup	An error occurred during the startup of the motor. Turn off the power to the pump and verify that the motor can be turned by using hand mode control. If the alarm persists after powering up contact an Armstrong Technical Service representative.
8	Other vsd	There has been an unknown alarm condition generated by the vsd. If the alarm persists after cycling power to the pump, contact an Armstrong Technical Service representative.
9	VSD communication	There is a communication issue between the control card and vsd. Turn off the power to the pump and check the connections between the control card and the vsd.
10	VSD speed	The speed set by the vsd is not within tolerance. If the alarm persists after cycling power to the pump, contact an Armstrong Technical Service representative.
11	VSD initialization failure	The control card was not able to receive the initial parameters correctly. Please try to restart the pump. If the alarm persists after restart, contact an Armstrong Technical Service representative.

7.2 WARNING SUMMARY FOR INTERFACES

WARNING NUMBER	NAME	WARNING DESCRIPTION
1	vSD over temperature	The temperature of a vSD or motor component is near the thermal warning limit. Check that the motor, fan and vSD cooling is functioning correctly. Verify that the pump is not overloaded. If the warning persists, contact an Armstrong Technical Service representative.
2	vSD over current	The vSD has detected current exceeding the warning limit. Turn the pump off. (If there is a discharge from the output phases to earth it can be verified by checking for any faults with a megohmmeter between ground and the motor leads.) If a current limit has been exceeded in the vSD check that the motor can be turned. If the pump is being overloaded reduce the pump speed using hand mode control. If the warning persists after powering up contact an Armstrong Technical Service representative.
3	External vSD voltage	The voltage into the vSD is out of range. Verify that the correct voltage required to operate the vSD is present by measuring each of the 3 phases. If the warning persists, contact an Armstrong Technical Service representative.
4	Internal vSD voltage	An internal voltage generated by vSD is out of range. If the warning persists, contact an Armstrong Technical Service representative.
5	Internal vSD	An internal warning in the vSD has occurred. If the warning persists, contact an Armstrong Technical Service representative.
6	Reserved	
7	vSD startup	A warning occurred during the startup of the motor. Turn off the power to the pump and verify that the motor can be turned using hand mode control. If the warning persists after powering up contact an Armstrong Technical Service representative.
8	Other vSD	There has been an unknown warning condition generated by the vSD. If the alarm persists, contact an Armstrong Technical Service representative.
9	vSD communication	There is a communication issue between the control card and vSD.
10	vSD speed	The speed set by the vSD is not within tolerance. If the alarm persists, contact an Armstrong Technical Service representative.
11	vSD wiring	There is an issue in wiring to the vSD. Check the wiring to the motor from the vSD. If any I/O are used on the vSD, verify that there is continuity and no shorts for the connections.
12	System over temperature	The temperature measured by the control card is approaching the recommended operating conditions.
13	System under temperature	The temperature measured by the control card is approaching the recommended operating conditions.
14	Battery under voltage	The battery voltage is low. Replace the battery with CR2032 type cell.
15	BMS communication loss	BMS communication has been lost.
16	vSD communication loss	The communication with the vSD and the control card has stopped.
17	Invalid vSD parameter	The control card has specified an invalid vSD parameter.
18	vSD initialization failure	The initialization of the vSD through Modbus has failed. Cycle power to the pump to re-initialize.
19	vSD speed set failure	The speed could not be set by the controller. Check the connections between the vSD and control card.
20	vSD start set failure	The controller could not start the motor. Check the connections between the vSD and control card.
21	Sensorless error	The sensorless map that was entered has an error please refer to the I & O Manual for further details.
22	Hand mode timeout	The pump has been in hand mode too long. Consider setting to automatic mode to save energy.

8.0 FUSE AND WIRE RECOMMENDATION

TABLE 1: UL FUSES, 200-240V

UL COMPLIANCE FUSES							
FREQUENCY CONVERTER	BUSSMANN	BUSSMANN	BUSSMANN	SIBA	LITTEL FUSE	FERRAZ SHAWMUT	FERRAZ SHAWMUT
kw	TYPE RK1	TYPE J	TYPE T	TYPE RK1	TYPE RK1	TYPE CC	TYPE RK1
K25-K37	KTN-R05	JKS-05	JJN-05	5017906-005	KLN-R005	ATM-R05	A2K-05R
K55-1K1	KTN-R10	JKS-10	JJN-10	5017906-010	KLN-R10	ATM-R10	A2K-10R
1K5	KTN-R15	JKS-15	JJN-15	5017906-015	KLN-R15	ATM-R15	A2K-15R
2K2	KTN-R20	JKS-20	JJN-20	5012406-020	KLN-R20	ATM-R20	A2K-20R
3K0	KTN-R25	JKS-25	JJN-25	5012406-025	KLN-R25	ATM-R25	A2K-25R
3K7	KTN-R30	JKS-30	JJN-30	5012406-030	KLN-R30	ATM-R30	A2K-30R
5K5	KTN-R50	JKS-50	JJN-50	5012406-050	KLN-R50	-	A2K-50R
7K5	KTN-R50	JKS-60	JJN-60	5012406-050	KLN-R60	-	A2K-50R
11K	KTN-R60	JKS-60	JJN-60	5014006-063	KLN-R60	A2K-60R	A2K-60R
15K	KTN-R80	JKS-80	JJN-80	5014006-080	KLN-R80	A2K-80R	A2K-80R
18K5	KTN-R125	JKS-150	JJN-125	2028220-125	KLN-R125	A2K-125R	A2K-125R
22K	KTN-R125	JKS-150	JJN-125	2028220-125	KLN-R125	A2K-125R	A2K-125R
30K	FWX-150	-	-	2028220-150	L25S-150	A25X-150	A25X-150
37K	FWX-200	-	-	2028220-200	L25S-200	A25X-200	A25X-200
45K	FWX-250	-	-	2028220-250	L25S-250	A25X-250	A25X-250

TABLE 2: UL FUSES, 380-480V, 525-600V

UL COMPLIANCE FUSES							
FREQUENCY CONVERTER	BUSSMANN	BUSSMANN	BUSSMANN	SIBA	LITTEL FUSE	FERRAZ SHAWMUT	FERRAZ SHAWMUT
kw	TYPE RK1	TYPE J	TYPE T	TYPE RK1	TYPE RK1	TYPE CC	TYPE RK1
K37-1K1	KTS-R6	JKS-6	JJS-6	5017906-006	KLS-R6	ATM-R6	A6K-6R
1K5-2K2	KTS-R10	JKS-10	JJS-10	5017906-010	KLS-R10	ATM-R10	A6K-10R
3K0	KTS-R15	JKS-15	JJS-15	5017906-016	KLS-R16	ATM-R16	A6K-16R
4K0	KTS-R20	JKS-20	JJS-20	5017906-020	KLS-R20	ATM-R20	A6K-20R
5K5	KTS-R25	JKS-25	JJS-25	5017906-025	KLS-R25	ATM-R25	A6K-25R
7K5	KTS-R30	JKS-30	JJS-30	5012406-032	KLS-R30	ATM-R30	A6K-30R
11K	KTS-R40	JKS-40	JJS-40	5014006-040	KLS-R40	-	A6K-40R
15K	KTS-R40	JKS-40	JJS-40	5014006-040	KLS-R40	-	A6K-40R
18K	KTS-R50	JKS-50	JJS-50	5014006-050	KLS-R50	-	A6K-50R
22K	KTS-R60	JKS-60	JJS-60	5014006-063	KLS-R60	-	A6K-60R
30K	KTS-R80	JKS-80	JJS-80	2028220-100	KLS-R80	-	A6K-80R
37K	KTS-R100	JKS-100	JJS-100	2028220-125	KLS-R100		A6K-100R
45K	KTS-R125	JKS-150	JJS-150	2028220-125	KLS-R125		A6K-125R
55K	KTS-R150	JKS-150	JJS-150	2028220-160	KLS-R150		A6K-150R
75K	FWH-220	-	-	2028220-200	L50S-225		A50-P225
90K	FWH-250	-	-	2028220-250	L50S-250		A50-P250

KTS-fuses from **Bussmann** may substitute KTN for 240v frequency converters.

FWH-fuses from **Bussmann** may substitute FWX for 240v frequency converters.

KLSR-fuses from **Littel Fuse** may substitute KLNLR fuses for 240v frequency converters.

L50S-fuses from **Littel Fuse** may substitute L50S fuses for 240v frequency converters.

A6KR-fuses from **Ferraz Shawmut** may substitute A2KR for 240v frequency converters.

A50X-fuses from **Ferraz Shawmut** may substitute A25X for 240v frequency converters.

9.0 PUMP MANAGER

Pump Manager is a cloud based analytics service providing real time alerts and insights on the flow and the system's efficiency. Pump Manager provides unique and critical insights to drive savings in energy, maintenance, emergency repairs and downtime costs.

Features

Secure IoT Connectivity

Plug 'n play setup, no LAN connection required. Pump connected to the IBM Watson analytics platform cloud via a 4G LTE router with built-in cellular modem. Authentication key and 1-way push notifications only with no inbound communication to pumps make for safe connection

Real Time Alerts

Know of problems before they occur. Pump Manager will alert you when something is wrong

Performance Reports

You can now view operation trends and make data informed decisions

Predictive Maintenance

The pump will advise which parts it needs! And tell you where to buy them as well

Building Management System Integration

Integrate the pump data to your building automation system via API so you can view all your assets in one place

Benefits

Lower Operating Costs

- Optimal operation for maximum energy efficiency
- Lower OpEx costs

Increase Availability & Reliability

- Reduce unexpected failures
- Early problem detection
- Faster return to service

Improve Comfort and Productivity

- Keep flows in the desired range, reducing temperature swings

Improve Building Resilience and Future Decisions

- Make informed capital investment decisions

Start Now in Two Easy Steps

<http://armstrongfluidtechnology.com/en/registration> OR
info@armstrongfluidtechnology.com

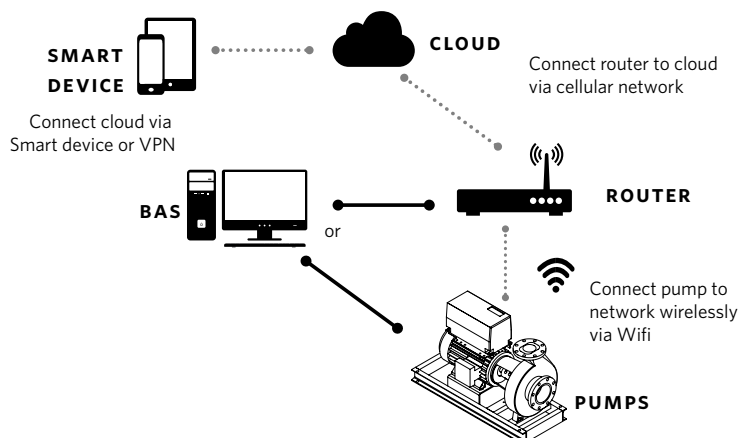

10.0 CONNECTIVITY KIT

Pump Manger integration procedure

This procedure describes the steps to connect an Armstrong Pump Manger router to a Design Envelope Pump with a DEPC controller.

Each site will be required to have a factory programmed router for data transfer (included with each Design Envelope Pump order).

Refer to **File No:** 100.8154 on Armstrong Corporate Website for full details.

TORONTO

23 BERTRAND AVENUE,
TORONTO, ONTARIO,
CANADA, M1L 2P3
+1 416 755 2291

BUFFALO

93 EAST AVENUE, NORTH
TONAWANDA, NEW YORK,
USA, 14120-6594
+1 716 693 8813

DROITWICH SPA

POINTON WAY, STONEBRIDGE CROSS
BUSINESS PARK, DROITWICH SPA,
WORCESTERSHIRE,
UNITED KINGDOM, WR9 0LW
+44 121 550 5333

MANCHESTER

WOLVERTON STREET, MANCHESTER
UNITED KINGDOM, M11 2ET
+44 161 223 2223

BANGALORE

#18, LEWIS WORKSPACE, 3RD FLOOR,
OFF MILLERS - NANDIDURGA ROAD,
JAYAMAHAL CBD, BENSON TOWN,
BANGALORE, INDIA 560 046
+91 80 4906 3555

SHANGHAI

UNIT 903, 888 NORTH SICHUAN RD.
HONGKOU DISTRICT, SHANGHAI
CHINA, 200085
+86 21 5237 0909

BEIJING

ROOM 1612, NANYIN BUILDING NO.2
NORTH EAST THRID RING ROAD
CHAOYANG DISTRICT, BEIJING,
CHINA 100027
+86 21 5237 0909

SÃO PAULO

RUA JOSÉ SEMIÃO RODRIGUES
AGOSTINHO, 1370 GALPÃO 6 EMBU
DAS ARTES, SAO PAULO, BRAZIL
+55 11 4785 1330

LYON

93 RUE DE LA VILLETTE
LYON, 69003 FRANCE
+33 4 26 83 78 74

DUBAI

JAFZA VIEW 19, OFFICE 402
P.O.BOX 18226 JAFZA,
DUBAI - UNITED ARAB EMIRATES
+971 4 887 6775

JIMBOLIA

STR CALEA MOTILOR NR. 2C
JIMBOLIA 305400, JUD.TIMIS
ROMANIA
+40 256 360 030

FRANKFURT

WESTERBACHSTRASSE 32,
D-61476 KRONBERG IM TAUNUS
GERMANY
+49 6173 999 77 55

ARMSTRONG FLUID TECHNOLOGY®
ESTABLISHED 1934

ARMSTRONGFLUIDTECHNOLOGY.COM