

Hard Flanged Circuit Balancing Valves 2½" - 12" (DN65 to 300)

Installation and operating instructions

File No: 36.88
Date: JANUARY 25, 2021
Supersedes: 36.88
Date: NOV. 20, 1998

—

—

—

—

CONTENTS

1.0	INSTALLATION	4
2.0	BOLT TIGHTENING	4
3.0	CONVERSION (STRAIGHT TO ANGLE)	4
4.0	OPERATION	4
5.0	MEMORY SETTING 2½" - 12" VALVES	5
6.0	REPOSITIONING HANDWHEEL 2½" - 12" VALVES	6
7.0	REPACKING CBV UNDER FULL SYSTEM PRESSURE 2½" - 12" VALVES	6
8.0	FLOW CURVES	6

ANGLE DESIGN

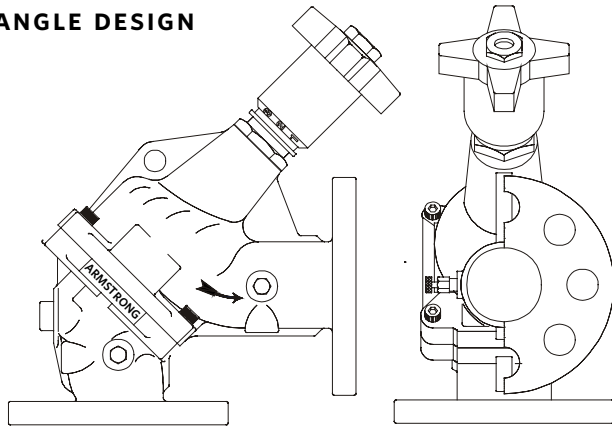

STRAIGHT DESIGN

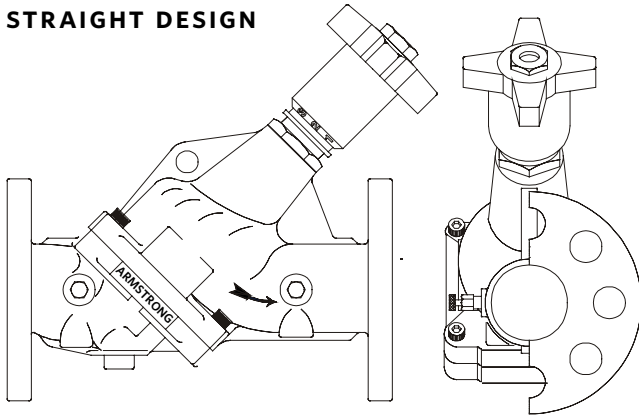

1.0 INSTALLATION

1.1 To ensure accuracy of measurement, the CBV should be located at least five pipe diameters downstream from any fitting and at least ten pipe diameters downstream from a pump. Two pipe diameters downstream from the CBV should be free of any fitting (as illustrated in **FIG 1**).

FIG. 1

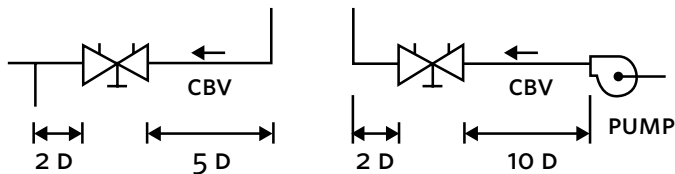

1.2 CBV valves must be installed with flow in the direction of the arrow on the valve body. Easy access to the probe metering ports (P.M.P's) and handwheel must be provided.

1.3 CBV valves can be installed in horizontal or vertical piping. The metering ports should never be installed below the pipe (pointing down), as this will allow system sediment to accumulate in the ports. (Illustrated below for horizontal piping in **FIG. 2**).

FIG. 2

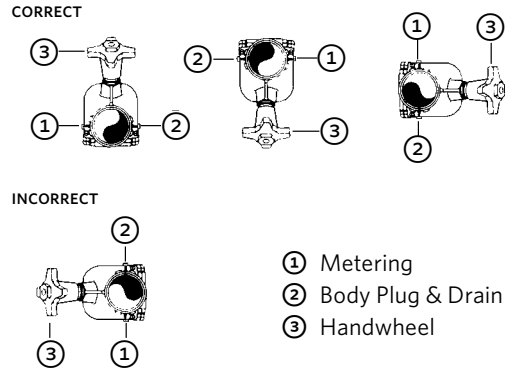

1.4 CBV angle-style valves are designed to replace piping elbows.

1.5 Metering ports and body plugs may be interchanged for improved accessibility.

2.0 BOLT TIGHTENING

2.1 Tighten all bolts evenly in standard star pattern. When used with a **raised face** flange, there will be a gap between the faces on the outer flange diameters.

3.0 CONVERSION (STRAIGHT TO ANGLE)

3.1 Open the valve one complete turn.

3.2 Remove the body bolts from the valve body.

3.3 Rotate one-half of the valve body, 180°, making sure the seat and "O" ring stay in position and do not get nicked or cut.

3.4 Replace the body bolts and tighten evenly.

4.0 OPERATION

4.1 The valve operates from closed (**FIG. 3**) to fully open by a counterclockwise rotation of the red handwheel. Using five (5) 380 turns for the 2½" and 3" valves, six (6) turns for the 4", 5", and 6" valves, 12 turns for the 8" and 10" valves and 14 turns for the 12" valve. Two scales indicate the position of the valve.

FIG. 3 With no arrows visible, the Inner Scale set at 0 on the indicator line aligned with the 0 on the Outer Scale; the valve is closed.

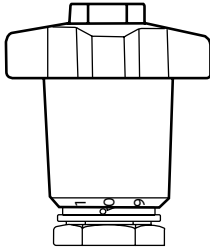

Inner Scale (FIG. 4 & 5)- This sleeve has a vertical arrowed scale which indicated the number of full turns the valve have been opened.

Outer Scale (FIG. 4 & 5)- This scale is a micrometer-type scale marked 0-9 at the tapered base of the handwheel. Each gives 1/10th indications for each 360 turn of opening against the indicator line of the Inner Scale. Connect meter quick-disconnect hoses to metering ports as follows:

- Remove protective cap from metering ports
- Insert and lock the meter probe into the metering ports

FIG. 4 Shows a valve setting of 2.0, indicating that the valve is partially open.

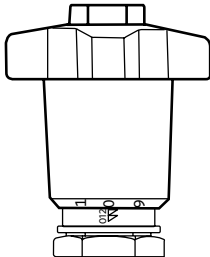
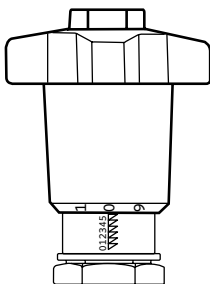

FIG. 5 With all arrows visible, the Inner Scale, set at 6 and the indicator line aligned with Outer Scale 0; the valve setting is 6.0 and the valve is fully open.



4.2 The hose with the red fitting upstream: the hose with the blue fitting downstream.

CAUTION



The probe should not be left inserted into the fitting for prolonged periods of time; overnight, etc, as leakage of the P.M.P., may occur when the probe is removed.

- 4.3** The locking nut on the probe is designed to hold it in the P.M.P. when taking readings in systems having a high working pressure. As sealing is accomplished internally on the probe stem, it is only necessary to tighten the locking nut finger-tight. Overtightening may cause damage to the P.M.P. or locking nut threads.
- 4.4** Safety glasses should be used.
- 4.5** Before taking a flow measurement reading, set the valve to its fully open (4.0) or at a preset position Read the pressure drop across the valve with an Armstrong CBDM-135/60. Determine GPM now by use of valve Cv, curve on **PAGES 7 and 8** or the Armstrong Circular Slide Rule.

5.0 MEMORY SETTING 2½"- 12" VALVES

FIG. 6

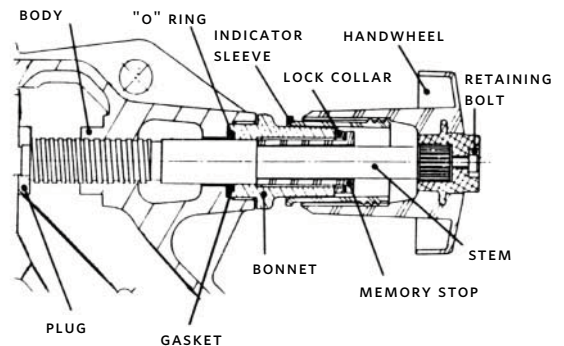

- 5.1** After the valve has been adjusted to its balance set point and without moving the handwheel, remove the retaining bolt from the end of the handwheel using a ¼" Allen wrench.
- 5.2** Carefully remove the handwheel and turn indicator sleeve assembly, leaving the valve at its balance set point.
- 5.3** Turn the plastic memory stop (clockwise) down until it stops. Finger-tight pressure is sufficient. Do not over-tighten.
- 5.4** Holding the memory stops in position, turn the lock collar (clockwise) down until it stops against the valve bonnet. The memory has now been set.
- 5.5** With the handwheel/turn indicator sleeve assembly still at its balance set point indication, reinstall them on the valve stem and hold in place with the ¼" retaining bolt.

CAUTION



Care must be taken not to rotate the valve stem or change the handwheel/indicator setting while setting the memory.

6.0 REPOSITIONING HANDWHEEL 2½"- 12" VALVES

- 6.1 The handwheel can be removed and repositioned in any of six positions around the stem.
 - A Close valve fully.
 - B Remove handwheel-retaining bolt.
 - C Remove handwheel and turn indicator sleeve by grasping the handwheel and pulling away from the valve body along the stem.
 - D Select a new position for easy reading and with the sleeve and handwheel held together in the closed position (0.0), push them back over the bonnet head and valve stem.
 - E Replace handwheel-retaining bolt.
 - F Open valve
- 6.2 If handwheel is removed for any reason, it is important to first close the valve and then replace the handwheel per 6.1 D and E above.
- 6.3 The Balancing Valve should not be used as a permanent isolation valve, however can be used for temporary shut off.

7.0 REPACKING CBV UNDER FULL SYSTEM PRESSURE 2½"- 12" VALVES

- 7.1 Open valve fully to its memory setting and, on a piece of paper, record the valve setting.
- 7.2 Remove the handwheel/indicator sleeve assembly as per 5.1 and 5.2
- 7.3 Loosen the lockcollar by turning it counter-clockwise until it seats against the top of the memory stop.
- 7.4 Remove the memory stop/lockcollar assembly by turning the plastic memory stop counter-clockwise.
- 7.5 Using the handwheel **with the indicator sleeve removed**, turn the valve stem counter-clockwise until the valve is fully open and will not turn any further (45 ft. lbs.). A step on the valve plug has now been back-seated against the upper portion of the valve body (metal-to-metal).
- 7.6 The valve bonnet may now be removed. There may be slight leakage, as the metal-to-metal backseating does

not provide a drip-tight seal.

- 7.7 Clean exposed portion of valve stem (Do not scratch).
- 7.8 Remove and replace the 'O' ring and gasket.
- 7.9 Install the valve bonnet.
- 7.10 Replace memory stop/lockcollar assembly into the valve bonnet. Close the valve fully by turning the stem in a clock-wise direction. Tightening valve bonnet is necessary to stop any leaks.
- 7.12 Replace handwheel/indicator sleeve assembly per 6.1 D and A above.
- 7.13 Open valve to balance set point as recorded in 7.1.
- 7.14 Reset memory per 5.0.

8.0 FLOW CURVES

CBV STRAIGHT AND CBV ANGLED - 2½ G/F

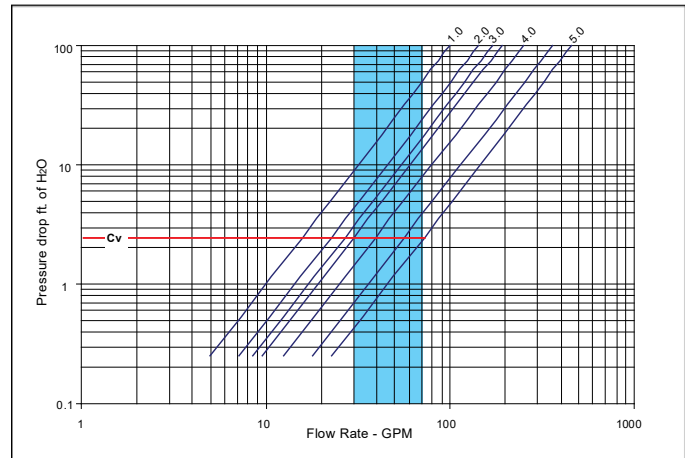

CBV STRAIGHT AND CBV ANGLED - 3 G/F

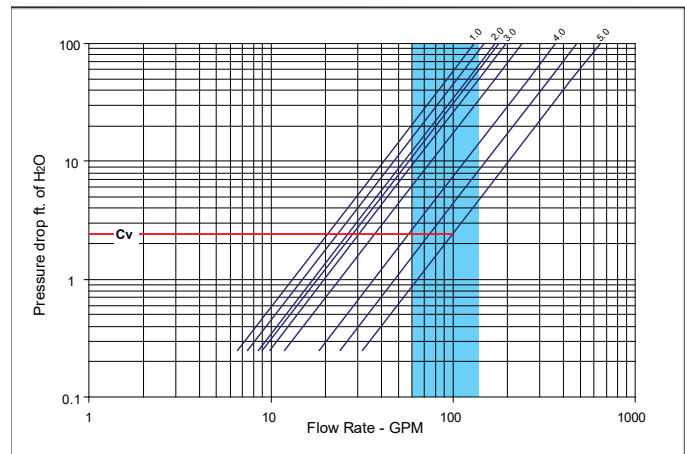

CBV STRAIGHT AND CBV ANGLED - 4 G/F

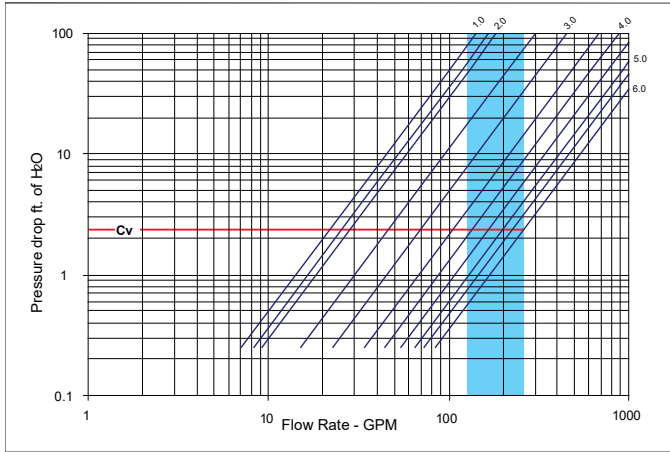

CBV STRAIGHT AND CBV ANGLED - 8 G/F

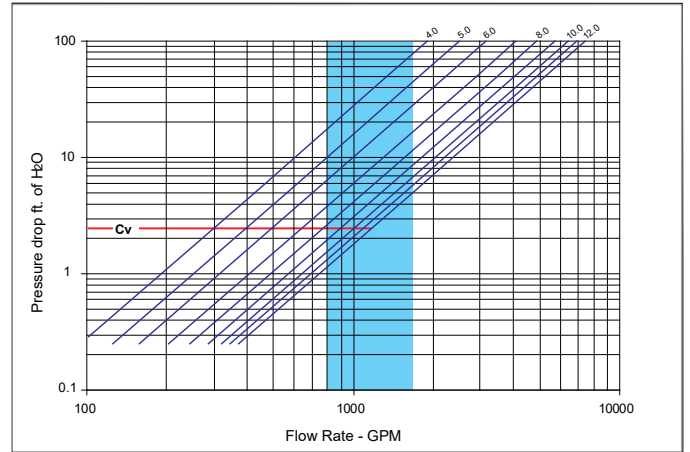

CBV STRAIGHT AND CBV ANGLED - 5 G/F

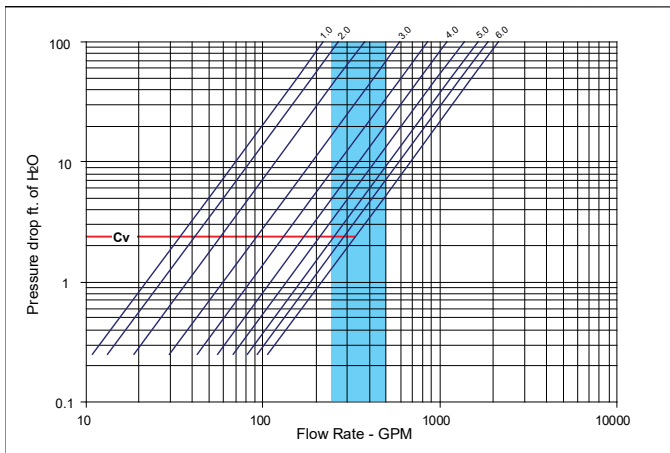

CBV STRAIGHT AND CBV ANGLED - 10 G/F

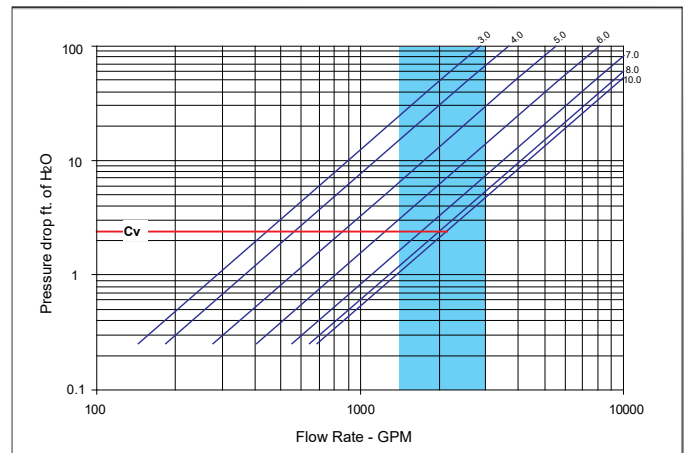

CBV STRAIGHT AND CBV ANGLED - 6 G/F

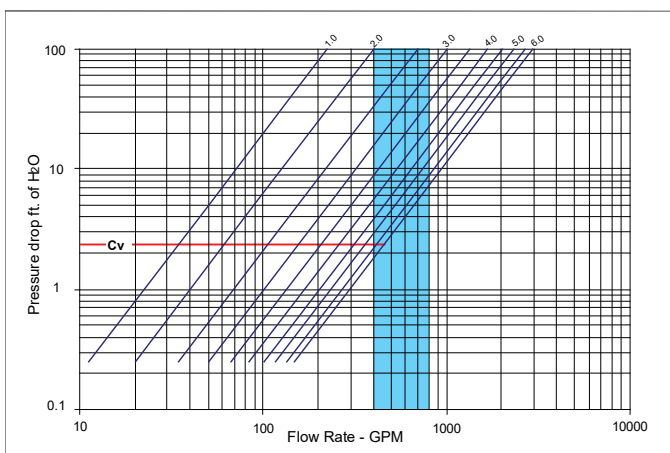

CBV STRAIGHT AND CBV ANGLED - 12 G/F

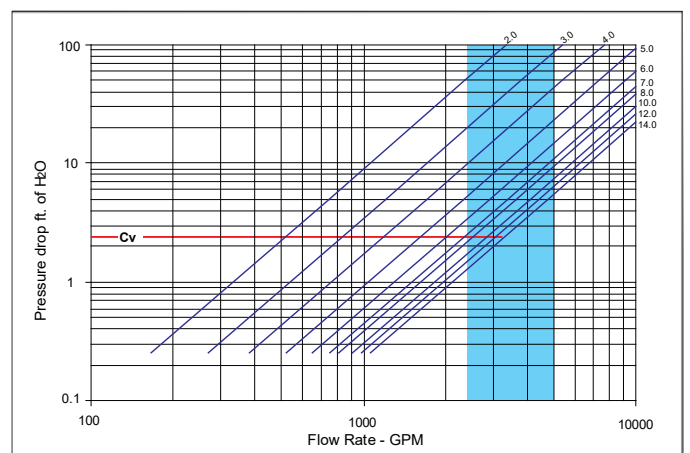

TORONTO

23 BERTRAND AVENUE,
TORONTO, ONTARIO,
CANADA, M1L 2P3
+1 416 755 2291

BUFFALO

93 EAST AVENUE, NORTH
TONAWANDA, NEW YORK,
USA, 14120-6594
+1 716 693 8813

DROITWICH SPA

POINTON WAY, STONEBRIDGE CROSS
BUSINESS PARK, DROITWICH SPA,
WORCESTERSHIRE,
UNITED KINGDOM, WR9 0LW
+44 121 550 5333

MANCHESTER

WOLVERTON STREET, MANCHESTER
UNITED KINGDOM, M11 2ET
+44 161 223 2223

BANGALORE

#18, LEWIS WORKSPACE, 3RD FLOOR,
OFF MILLERS - NANDIDURGA ROAD,
JAYAMAHAL CBD, BENSON TOWN,
BANGALORE, INDIA 560 046
+91 80 4906 3555

SHANGHAI

UNIT 903, 888 NORTH SICHUAN RD.
HONGKOU DISTRICT, SHANGHAI
CHINA, 200085
+86 21 5237 0909

BEIJING

ROOM 1612, NANYIN BUILDING NO.2
NORTH EAST THRID RING ROAD
CHAOYANG DISTRICT, BEIJING,
CHINA 100027
+86 21 5237 0909

SÃO PAULO

RUA JOSÉ SEMIÃO RODRIGUES
AGOSTINHO, 1370 GALPÃO 6 EMBU
DAS ARTES, SAO PAULO, BRAZIL
+55 11 4785 1330

LYON

93 RUE DE LA VILLETTE
LYON, 69003 FRANCE
+33 4 26 83 78 74

DUBAI

JAFZA VIEW 19, OFFICE 402
P.O. BOX 18226 JAFZA,
DUBAI - UNITED ARAB EMIRATES
+971 4 887 6775

JIMBOLIA

STR CALEA MOTILOR NR. 2C
JIMBOLIA 305400, JUD.TIMIS
ROMANIA
+40 256 360 030

FRANKFURT

WESTERBACHSTRASSE 32,
D-61476 KRONBERG IM TAUNUS
GERMANY
+49 6173 999 77 55

ARMSTRONG FLUID TECHNOLOGY®
ESTABLISHED 1934

ARMSTRONGFLUIDTECHNOLOGY.COM