



Installation and operating instructions

3760 ProVDG Range Pressurisation Equipment

Combined Pressurisation and
Vacuum Degassing Equipment

File No: 37.205
Date: JULY 10, 2023
Supersedes: NEW
Date: NEW

—

—

—

—

CONTENTS

Pressures in A Sealed System	4	Maintenance	30
About this Manual	6	Visual Inspection	30
Conventions used in this Manual	6	Interrogate Controller	30
Typography	6	Test Unit Operation	30
Pro PDG Equipment Overview	7	Check Float Valve Operation	31
Principal of Operation	7	Check Float Switch Operation	31
Installation	9	Check Break Tank Water Condition	31
Pipe Connections	9	Check Strainer	31
Typical Installation Diagram	10	Check PRV Strainer	31
ProVDG Clearance and Connection Requirements	12	Check Expansion Vessel Pre-Charge	32
Electrical Power Supply	13	Wiring	33
Micro Controller	14	Troubleshooting	34
Fault contacts	14	Warranty Details	38
Commissioning	15	Warranty - What Is Covered?	38
Pre-Commissioning Checklist	15	Warranty - What Is Not Covered?	38
Controller Overview	16	Conditions of warranty	38
Program Parameter List	18	Contact Details	38
PR No (36) Purge Seconds Reference	21	Statement of compliance	39
Times options	21		
Hydraulic Commissioning	22		
1. Float valve setting	22		
2. Bleeding Pumps	22		
3. Forcing Pumps to Run	24		
4. Venting the vacuum cylinder	25		
5. Testing	26		
Operation	27		
Fault Codes	27		
Shutdown procedure	28		
Start-up Procedure	29		

Pressures in A Sealed System

Below is an overview of how the settings on a pressurisation unit must be considered for normal topup operation.

Close, conflicting or overlapping settings will cause system instability and nuisance alarm conditions. If in any doubt please seek advice from a Sealed System professional.

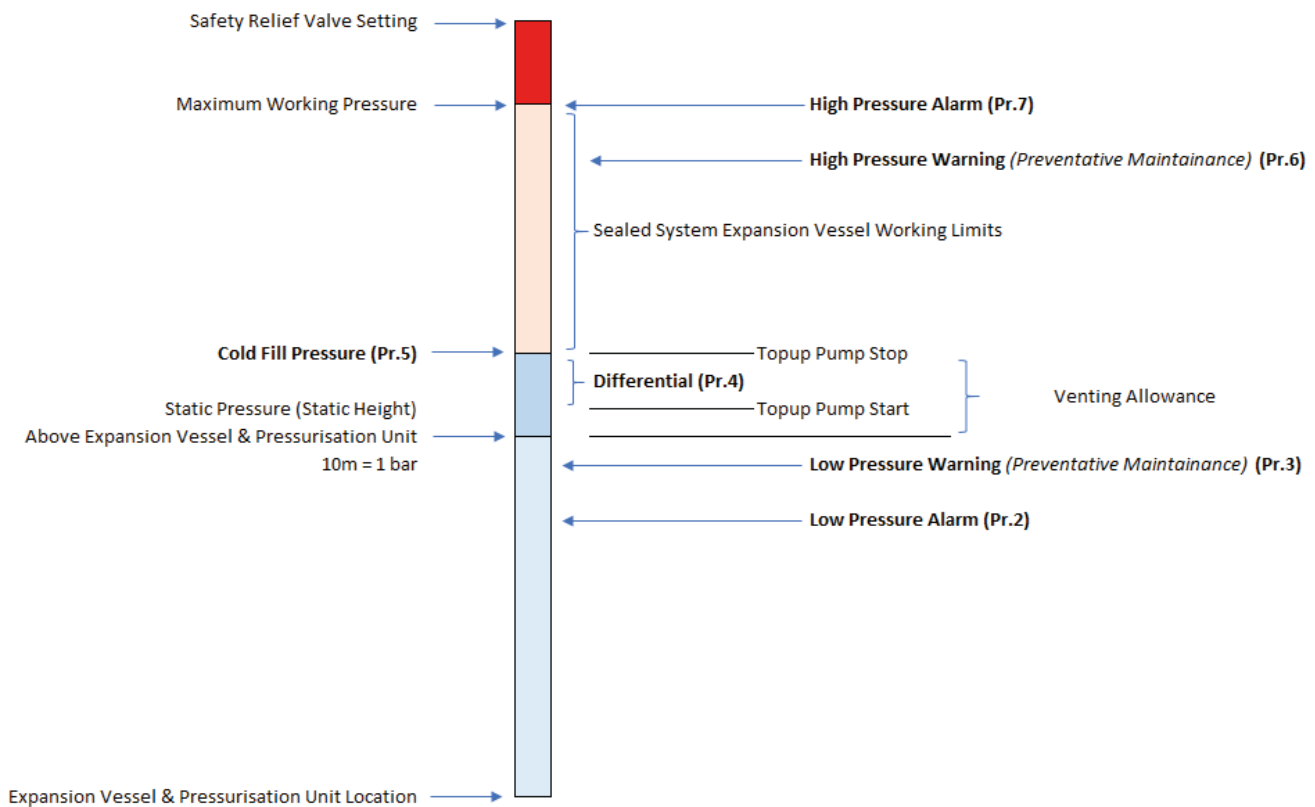

A typical venting allowance is 0.3 bar, added to the static height to give the cold fill pressure.

The Differential setting represents the allowable pressure loss before the pump activates and restores the cold fill pressure. The Differential setting must not be greater than the system venting allowance. This will ensure that the system remains fully flooded during normal topup conditions.

When the equipment contains a degassing element, the following pressures must also be taken into account.

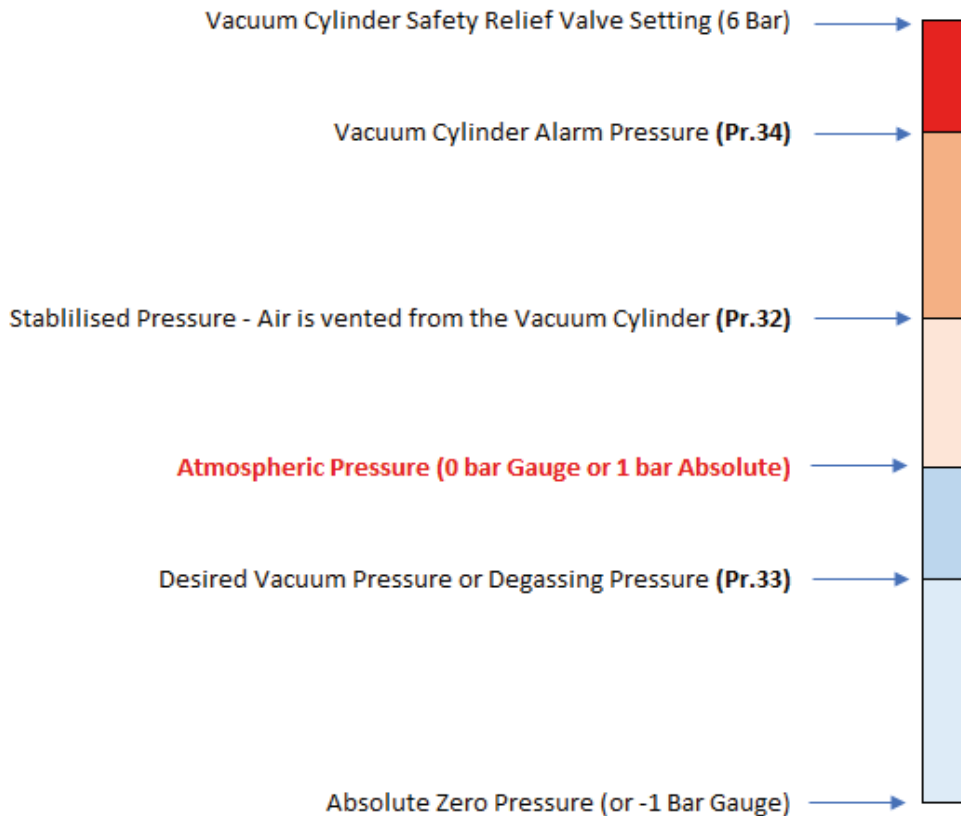

The degassing element will connect and disconnect from the main system as required to perform its normal function, a pressure reducing valve is also incorporated into the assembly to prevent overpressure of this technology. As a result, the vacuum cylinder can be protected with a 6 bar Safety Relief valve regardless of the main hydronic system pressure.

Typically, the Vacuum Cylinder Alarm Pressure is factory set to 4 bar, the Stabilised Pressure is set to 1 bar and the Desired Vacuum Pressure is set to -0.5 bar.

On Heating systems, the Desired Vacuum Pressure must be adjusted to meet the Steam Tables for the incoming fluid temperatures. It is important to note that at 70 deg. C, water subjected to a vacuum pressure of -0.5 bar (Gauge) will turn to low temperature steam and be vented from the equipment. This can affect the integrity of the Hydronic System and also influence the chemical dosing regime.

Close, conflicting or overlapping settings will cause system instability and nuisance alarm conditions. If in any doubt please seek advice from a Sealed System professional.

About this Manual

This Operation and Maintenance Manual contains all the necessary information to install, commission, operate and maintain the ProVDG Prestige equipment.

It is recommended to read all parts of this manual before undertaking any work on the equipment.

Conventions used in this Manual

This manual makes use of symbols to identify key pieces of information. Please take note of the following symbols and their meaning:



DANGER - Important safety related information intended to prevent injury and/or damage to the equipment, system or property.



CAUTION - Important information intended to prevent damage to the equipment, system or property.



IMPORTANT - Important information intended to ensure that the equipment functions correctly.



USEFUL - Useful information which may be helpful, but is not necessarily required for the unit to function correctly.

Typography

This manual makes use of different typography to identify different types of information.

Italics	Key words and phrases
(Round Brackets)	Used to identify a button on the digital controller
[Square Brackets]	A parameter on the digital controller
<Inequality Symbols>	A message/fault code displayed on the digital controller

Pro PDG Equipment Overview

The function of this pressurisation unit is to provide a means of automated water top-up to sealed heating and cooling systems. The equipment is designed to provide periodic water top-up to compensate for minor losses in system pressure (e.g. slow leaks, air venting, etc.). The equipment also samples system fluid, and subjects it to a controlled pressure drop for the purposes of mechanically removing dissolved gasses from solution to reduce the corrosive potential of the fluid.



This equipment is not designed to cope with sudden losses of system pressure (e.g. manual draining) or major water losses (e.g. large leaks). The equipment is also not intended to be used for water boosting applications.

Principal of Operation

The following schematic shows the internal arrangement of a combined Vacuum Degassing and pressurisation unit:

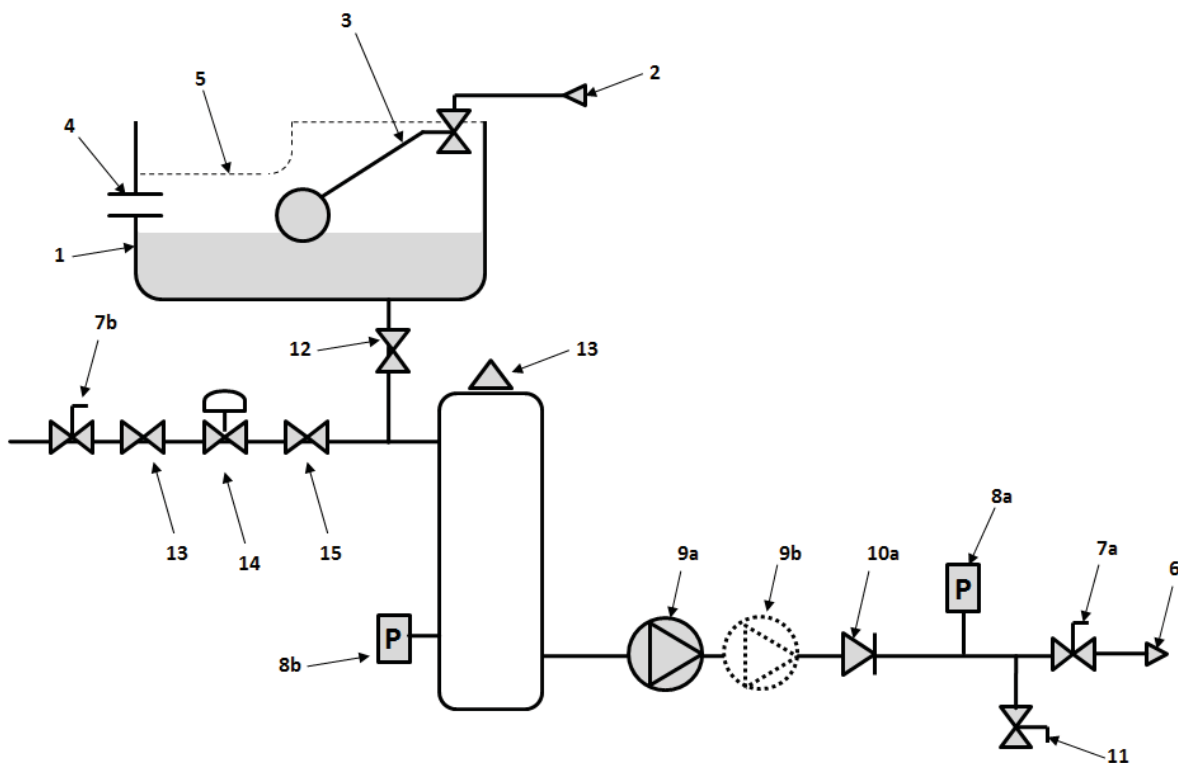

Water is allowed into the Vacuum cylinder through a safety solenoid (13), a pressure reducing valve (14) and a special variable bypass valve (15).

The pressure reducing valve (14) is used to limit the water held within the vacuum cylinder to approximately 1.2 bar. This is seen as the first pressure step.

8

The pressure reducing valve (17) is used to limit the water held within the vacuum cylinder to approximately 1.2 bar. This is seen as the first pressure step.

When the vacuum cylinder is full and registering a suitable start pressure (8b) the pumps (9a/9b) activate. At the same time the special variable bypass valve (15) opens fully to allow the cylinder water to be completely flushed back into the system by the pumps (9a/9b). This purge cycle ensures that the maximum possible amount of aerated water will be exposed to the vacuum process.

After the vacuum cylinder has been refreshed, the variable bypass valve (16) restricts the flow into the vacuum cylinder. The pumps (9a/9b) continue to draw water out of the cylinder and create a vacuum within the cylinder. The pumps (9a/9b) then stop after a 5 second dwell period.

The vacuum created within the cylinder is eroded by the incoming water through the variable bypass valve (15) at a low flow rate, this gently increases the pressure within the cylinder and forces the released air pocket out through the Automatic Air Vent (AAV) on top of the cylinder.

The equipment is connected to the main system via 2 isolation valves (7a/7b) and backflow from the system is prevented by a non-return valve (10a).

The integral pressurisation unit is fitted with a break tank (1) which is filled from the mains water supply (2) via a float operated valve (3). The break tank is fitted with an overflow (4) in case the break tank overfills, and a weir overflow (5) in case the primary overflow fails.

The break tank is connected into the degassing system via a solenoid valve (18b).

The pressure sensor (8a) monitors the system pressure.

If the pressure sensor detects a drop-in pressure, the degassing controller will power down, the break tank solenoid (12) will open and the pump (9a) will pump water from the break tank (1) into the system. Once the required pressure has been reached, the pump will stop, closing the solenoid valve (18b) and restoring electrical power to the degassing controller.

On twin pump models, a second pump (9b) is provided. The two pumps will run in a duty/standby configuration (i.e. the active pump will alternate with each pump start).

The pump(s) are fitted with a non-return valves (10a) to prevent backflow.

A drain valve (11) is provided for draining down the unit and for commissioning purposes.

Installation



This equipment is not designed to be installed in an outdoor environment. The unit must be installed in a frost-free environment, away from precipitation and water sprays/jets. If there is a risk of flooding, the unit must be installed on a raised plinth.



The unit is equipped with a Category 5 Weir overflow arrangement and must not be installed / sited where damage to the local environs can occur on water egress



Please refer to the appropriate datasheet for the maximum working pressure and temperature of the pressurisation unit. The conditions at the point of connection to the system must not exceed these values.

Pipe Connections



To avoid damaging the float valve, the mains water supply pipe must be flushed before connection to the pressurisation unit.



All pipe connections must be made with appropriate jointing compound/PTFE tape. If PTFE tape is used, care must be taken to ensure that the tape does not obstruct the orifice of the fitting.



Non-return valves, pressure reducing valves and RPZ valves must not be installed between the pressurisation unit and the heating/cooling system. These devices will prevent the pressure sensor from reading the system pressure.



The pressurisation unit and expansion vessel should be connected to the system at the same point, to provide a neutral pressure reading. This point of connection should be in the system return, on the suction side of the circulation pump.



Connections to the return header of the system must be made in the horizontal plane, to prevent system borne debris entering the equipment. Where 2 connections are required to the system return header, they must join the header at 2 distinctly separate points at least 500 mm apart

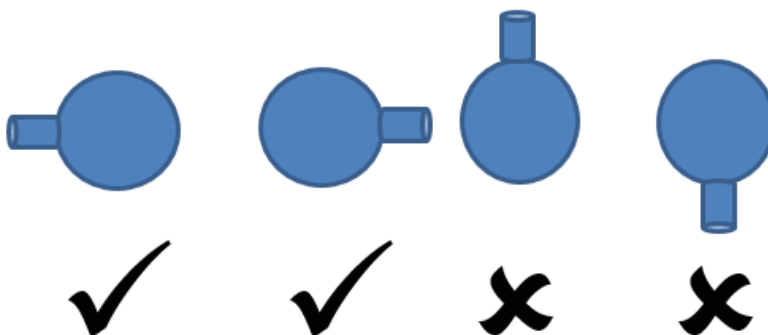

Typical Installation Diagram

Top fill vessels

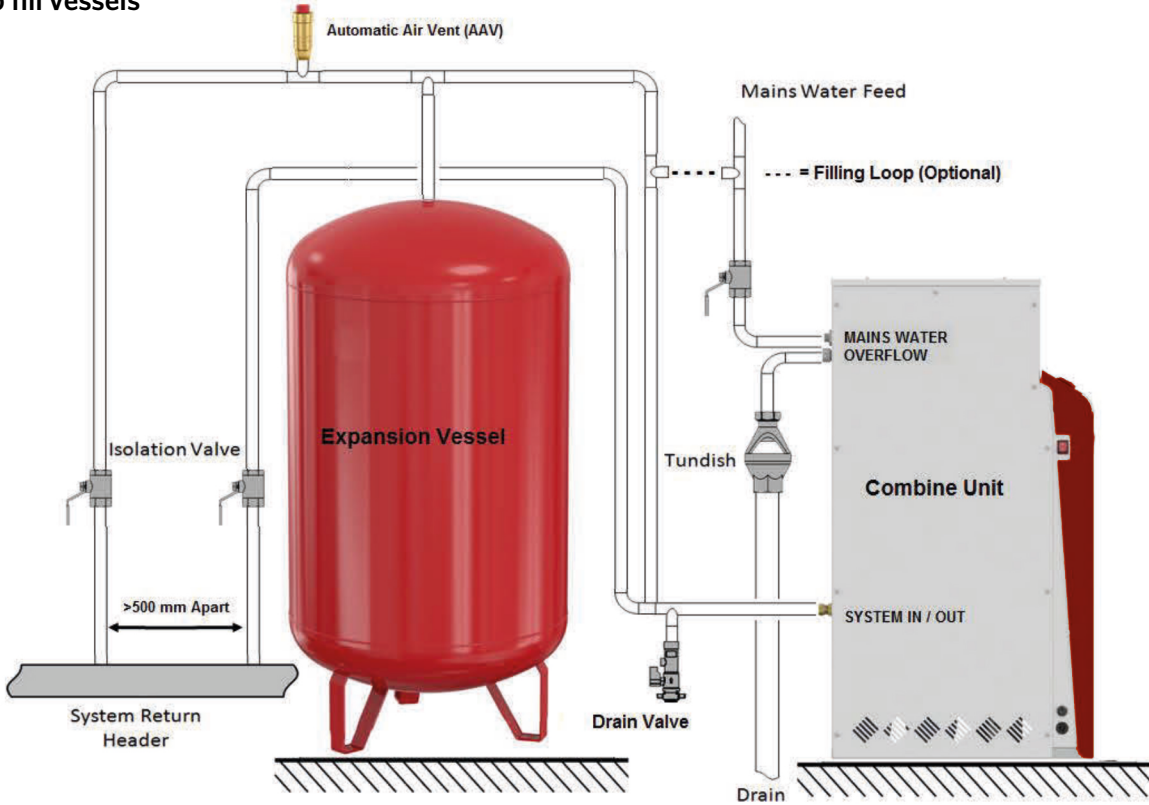

System In / Out Connection

Connection to nearest on/off switch = System In (Flow)

Connection other side of cabinet = System Out (Return)

Return connection Expansion vessel is connected to this line

System In/ Out need to be >500 mm apart

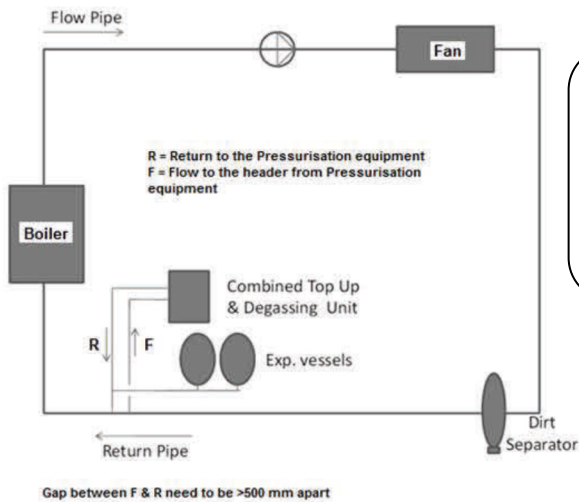

REMEMBER TO FIT AN INLINE STRAINER VALVE BEFORE THE UNIT TO ELIMINATE ANY DEBRIS GOING INTO THE PRO PDG UNIT. THIS HELP THE PERFORMANCE OF UNIT AND CAUSE LESS FAILURE OF THE EQUIPMENT

The isolation valve should not place near the safety valve.

Bottom fill vessels

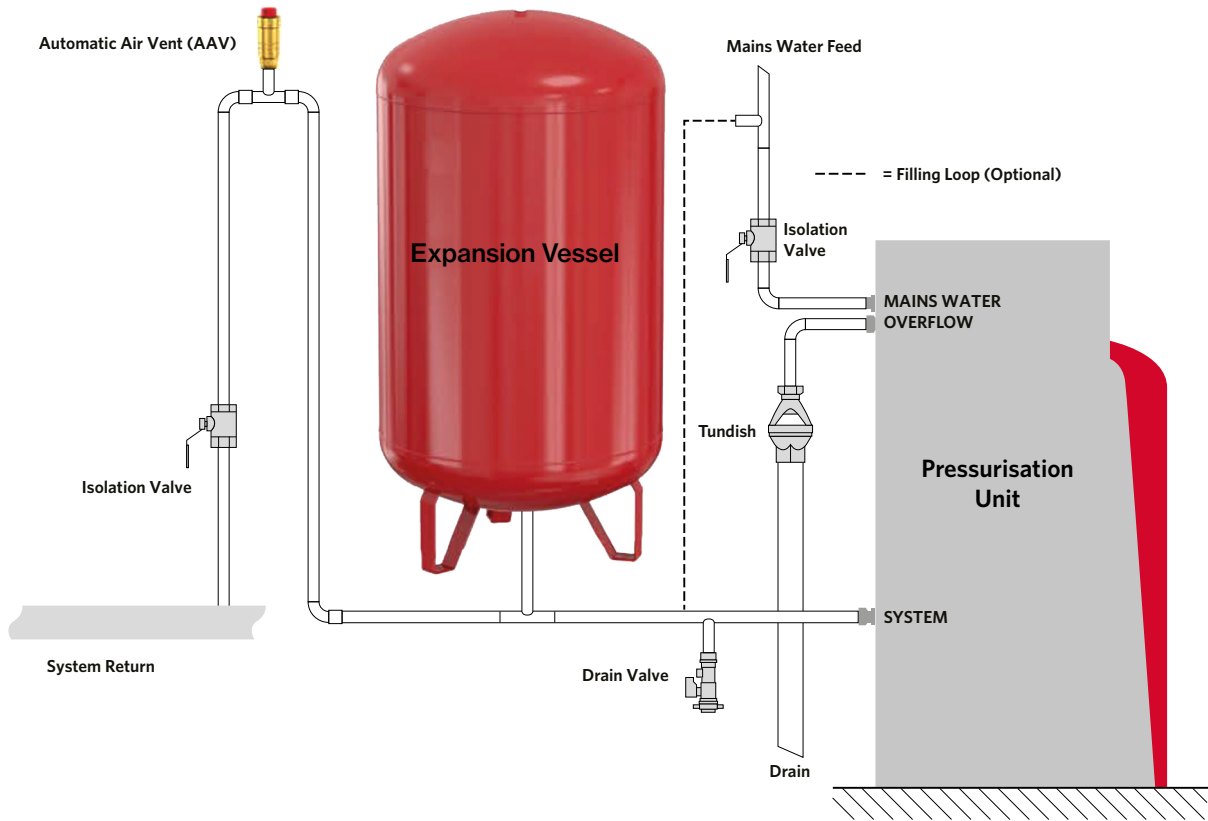

ProVDG Clearance and Connection Requirements

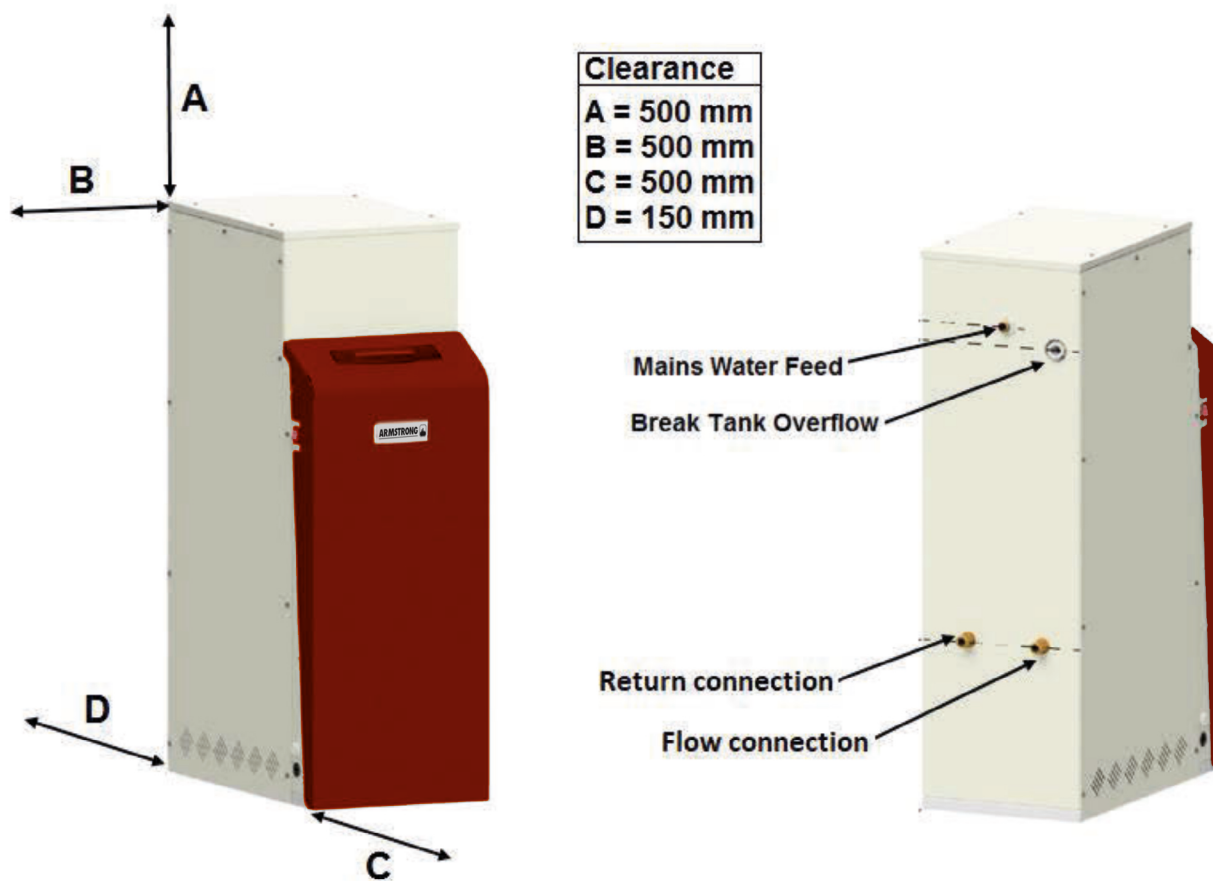

Connection	Size	Notes
Mains Water Feed	½" BSP M	An isolation valve must be installed on the mains water feed for servicing.
Break Tank Overflow	22 mm	Guidance on drainage requirements should be obtained from the local water authority.
System Connections (Flow & Return)	2 x ½" BSP M / 15mm	The point of connection should be in the system return, on the suction side of the circulation pump. Non-return valves, pressure reducing valves and RPZ valves must not be used.

Electrical Power Supply



This equipment must be electrically isolated before removing the covers. Cables connected to the volt free contacts may be supplied from another source and may remain live after the unit is isolated. These must be isolated elsewhere.



All electrical connections must be carried out by a suitably qualified and competent person.

The mains power supply to the pressurisation unit must be connected as shown below:

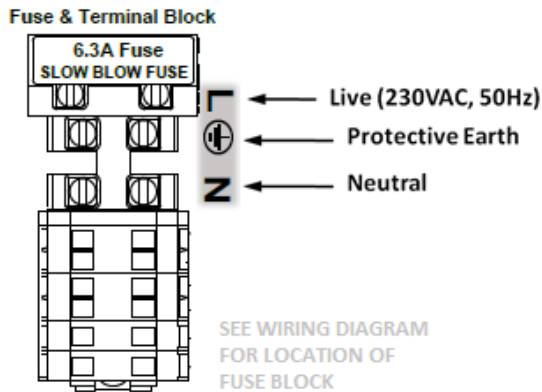

It is recommended to supply power to the pressurisation unit via a lockable isolator. This should be installed within 2m of the equipment.



This equipment can be damaged by the high voltages produced by electrical installation testing equipment. When performing electrical installation tests, the equipment must be isolated from the supply.

Micro Controller

Fault contacts

There are 6 volt free fault contacts which can be used for connection to a BMS system, located on terminals 1-12 on the digital controller.

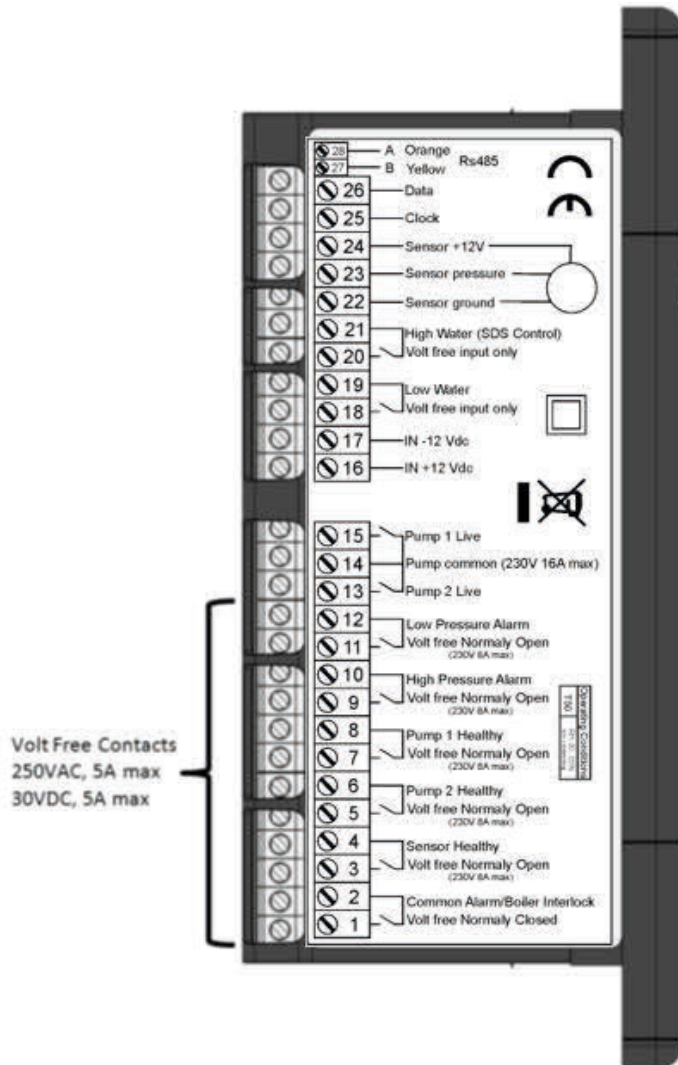

With the exception of the Common Alarm, it is possible to convert all other fault contacts to normally closed. For further information please refer to the commissioning section of this manual.



The other volt free contacts can be connected to the BMS and when the alarm is triggered this is shown on the Pressurisation unit and the BMS.

Commissioning



It is highly recommended to have this equipment commissioned by an Armstrong approved engineer. Any damage or loss incurred through incorrect commissioning by an unapproved engineer will not be covered by the warranty.

Pre-Commissioning Checklist



The following conditions must be met before starting the commissioning process. Failure to meet these conditions may result in injury or damage to the equipment, system and property.

- Equipment is sited in a frost-free area, away from precipitation and water sprays/jets
- All necessary pipe/electrical connections have been made to a satisfactory standard
- The temperature and pressure at the point of connection are within the operating limits of the pressurisation unit.
- The heating/cooling system is fitted with a safety valve and expansion vessel



The following conditions must be met for the pressurisation unit and heating/cooling system to function correctly. If these conditions have not been met, it is not advisable to proceed with the commissioning process.

- The system connection has been made into the system return header / pump suction
- There are no non-return valves, pressure reducing valves or RPZ valves installed between the pressurisation unit and the heating/cooling system
- The expansion vessel is pre-charged to the correct pressure (equal to PU cold fill pressure)



It is advisable to fill the heating/cooling system prior to commissioning. If this is not possible, the pressurisation unit can be used to fill the system after commissioning (Not possible with Mini Units). Depending on the size of the system, this may take a considerable amount of time.

- The heating/cooling system is filled and pressurised to the required cold fill pressure, with the water at ambient temperature (approximately).

Controller Overview

The following image shows the front of the pressurisation unit digital controller. 4 buttons are provided for programming, and an LED display which shows scrolling messages.



When the controller is first powered up, it will display the controller version number. This manual relates to controller version >10.0. If the controller is of a different version, there may be differences in the menu items available.

When in normal operation, the controller will display the current system pressure. If a fault occurs, the controller will display a fault code and produce an audible alarm.

In normal operation, the functions of the buttons are as follows:

Button	Function	
	Press	Hold
SET	-	Show Current System Pressure
MUTE	Mute Audible Alarm	Reset Unit
+	-	Enter Programming Menu
-	-	Enter Programming Menu

Controller Programming



Do not alter any settings without first understanding the implications of doing so. Incorrect settings may cause damage to the equipment, wider system or property.

To enter the programming menu, hold the (+) button until “enter code” appears on the screen, followed by “9999” with a flashing cursor after the first digit.

To gain access to the programming menu, the following code must be entered:

Standard Code	Standard set of options	2601
---------------	-------------------------	-------------

To enter the code, change the first digit with the (+) and (-) buttons, then press (SET) to move onto the next digit. Repeat for all digits, then once the correct code is shown on the display, press (SET) to enter the programming menu.

Once a correct code has been entered, the first option PROO - **Language** will appear select E and then press and hold (SET) & (+) to move to next menu.

Once in the menu, the value of the current menu item can be changed using the (+) and (-) buttons. Once the current value has been set, pressing the (SET) & (+) buttons together to move to the next option or (SET) & (-) buttons together to move back an option is you made an error.

Once the programming is complete press and hold the (SET) button for few seconds to save the settings.



If the controller loses power while in the programming menu, all changes made up to that point will be erased. To confirm all changes, the end of the menu must be reached, and press and hold the (SET) button for few seconds to save the settings

Key:

(SET) & (+) = Move to next menu

(SET) & (-) = Move back to pervious next menu

Hold down (SET) = Hold (SET) button down for few seconds saves the menu

Program Parameter List

The table below gives details of all menu items, in the order that they will appear:

PR No	Customer Code - 2601	Notes	Default	Unit
0	Language	E=English I=Italian D=Deutsch F=French N=Netherland	E	
2	Low Pressure Alarm	0.5 bar less than Fill Pressure	0.5	Bar
3	Low Pressure Warning	0.6 Bar less than Fill Pressure	0.6	Bar
4	Differential	'cut-in' and 'cut-out' between pumps	0.2	Bar
5	Fill Pressure	System pressure + 0.3 venting allowance	1	Bar
6	High Pressure Warning	High pressure alarm – 0.1 Bar	2.6	Bar
7	High Pressure Alarm	System safety valve - 10%	2.7	Bar
8	Flood Limit		10	minutes
9	Excessive Start Quantity		0	
10	Excessive Start Time		8	hours
28	Fill system		N	
45	Service Reminder Y/N		N	
48	ID Number	MODBUS ID number	1	
49	Review Logs		N	
50 (*)		Counter for P1 used for Topup		
51 (*)		Hours Run for P1 Topup		
52 (*)		Counter for P2 used for Topup		
53 (*)		Hours Run for P2 Topup		
54 (*)		Total Hours run P1 (inc Degassing)		
55 (*)		Total Hours run P2 (inc Degassing)		
56 (*)		Alarm Counter		
57 (*)		Power interrupted counter		

STANDARD OPTION

(*) IF REVIEW LOG IS YES THEM PR NUMBER 50 - 57 WILL BE ACTIVE

This menu only brings up standard option for the pressurisation equipment, to set up the degasser option of the equipment then you need to put in an engineers code and follow the menu list on the next pages.

This menu is for setup combine unit in order the menu will appear:

PR No		Notes	Default	Unit	
0	Language	E=English I=Italian D=Deutsch F=French N=Netherland	E		
1	Topup Required Y/N		Y		TOP-UP MENU
2	Low Pressure Alarm	0.5 bar less than Fill Pressure	0.5	Bar	
3	Low Pressure Warning	0.6 Bar less than Fill Pressure	0.6	Bar	
4	Differential	'cut-in' and 'cut-out' between pumps	0.2	Bar	
5	Fill Pressure	System pressure + 0.3 venting allowance	1	Bar	
6	High Pressure Warning	High pressure alarm – 0.1 Bar	2.6	Bar	
7	High Pressure Alarm	System safety valve - 10%	2.7	Bar	
8	Flood Limit		10	minutes	
9	Excessive Start Quantity		0		
10	Excessive Start Time		8	hours	
11	Pump Number		1		
12	Pump Type	Pump Type C (current monitored centrifugal pump) Pump Type P (current monitored Piston pump) Pump Type R (Not Current Monitored, larger pump/motor contactor etc)	C		
13	Pump Current Min Level		0.2	mA	
14	Current Sense		Y		
15	Periodic Pulse		Y		
16	Pressure Sensor Max Pressure	Maximum pressure that the pressure sensor can take	10	Bar	
17	Pressure Sensor Min Voltage	Set to 2 for 4-20mA sensor	2	Volts	
18	Pressure Sensor Max Voltage	Set to 10 for 4-20mA sensor	10	Volts	
19	Slave Unit	SPC Mode, high water switch activates pumps	N		
20	Additive Unit	Only active if the unit has additive tank	N		
21	Overrun	Pump Overrun after achieving set pressure (or Slave/SPC command is deactivated)	5	Seconds	

PR No		Notes	Default	Unit	STANDARD OPTION
22	Pressure Alarm Auto Reset	Toggles High/Low Alarm from being automatic reset to manual reset/critical stop	Y		
23	All VFC Fail Safe	Toggles all VFC alarms to be energised, normally closed. Break/open on fault	N		
24	Tank Solenoid	Uses High Water contact to activate a tank topup solenoid	N		
25	Tank Solenoid Overrun	Overrun command for filling solenoid	5	Seconds	
26	Zero Start	Allows topup unit to start immediately if switched on and seeing 0 bar (formerly boost option)	N		
27	Cascade	Delay start time for activating both pumps together [note 0 means that the pumps will NOT run together, but operates as duty/standby/auto change over	0	Seconds {disabled}	
28	Fill system		N		
29	Extended Mode		N		
30	not used		N		

PR No		Notes	Default	Unit	DEGASSER MENU
31	Degassing Required Y/N		Y		
32	Stabilised Pressure	Internal Safe Pressure Within the Vacuum Cylinder for The Pumps To Start Circulating Water	1	Bar	
33	Degassing Pressure	Internal Stop Pressure for The Pumps, Required Vacuum Pressure	-0.5	Bar	
34	Vac Cylinder Alarm Pressure	Internal High-Pressure Alarm Setting, To Activate the Slamshut Solenoid Valve	5	Bar	
35	Stabilisation Time	Normal Interval Between Pump Runs (Degassing)	10	Minutes	
36	Purge Time	Time Setting for Water to Be Re-circulated Into the Main System, Taking A Fresh Sample	20	Seconds	
37	Degassing Overrun	Pump Overrun after achieving degassing pressure	5	Seconds	
38	Turbo Mode Y/N	Activation Option for Turbo Mode (Commissioning Setup)	Y		
39	Turbo Hours	Running Time for Turbo Mode Before Returning To Normal	168	Hours	

PR No		Notes	Default	Unit	DEGASSER MENU
40	Normal Minutes	Wait time in between degassing cycles when not in Turbo Mode	60	Minutes	
41	Vacuum Sensor Min Pressure	Minimum pressure vacuum sensor will take	-1	Bar	
42	Vacuum Sensor Max Pressure	Maximum pressure vacuum sensor will take	15	Bar	
43	Vacuum Sensor Min Voltage	Set to 2 for 4-20mA sensor	2	Volt	
44	Vacuum Sensor Max Voltage	Set to 10 for 4-20mA sensor	10	Volt	

PR No		Notes	Default	Unit
45	Service Reminder Y/N		N	
46	Pump1 Max Hours Run	Alarm to change Pump (when set to 0 the alarm is disabled)	9000	
47	Pump 2 Max Hours Run	Alarm to change Pump (when set to 0 the alarm is disabled)	9000	
48	ID Number	MODBUS ID number	1	

49	Review Logs		N	
50 (*)	P1 Topup Count	Counter for P1 used for Topup		
51 (*)	P1 Topup Hours	Hours Run for P1 Topup		
52 (*)	P2 Topup Count	Counter for P2 used for Topup		
53 (*)	P2 Topup Hours	Hours Run for P2 Topup		
54 (*)	P1 Total Hours	Total Hours run P1 (inc Degassing)		
55 (*)	P2 Total Hours	Total Hours run P2 (inc Degassing)		
56 (*)	Alarm Count	Alarm Counter		
57 (*)	Power Interrupted Count	Power interrupted counter		

(*) IF REVIEW LOG IS YES THEM PR NUMBER 50 - 57 WILL BE ACTIVE

PR No (36) Purge Seconds Reference Times options

Main System Pressure	Purge Time
1.0 to 3.5 bar	20 seconds
3.5 to 5.0 bar	30 seconds
5.0 to 6.0 bar	40 seconds
6.0 to 7.0 bar	60 seconds
7.0 to 8.0 bar	120 seconds

Hydraulic Commissioning

1. Float valve setting

Ensure that the break tank float valve is set to its lowest position:

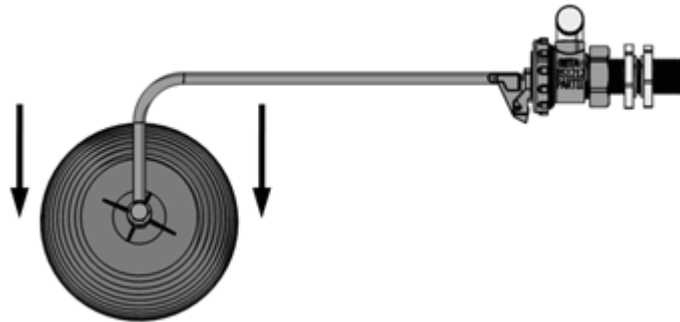

If a drain valve is fitted to the break tank, ensure that it is closed. Then, turn on the mains water supply and allow the break tank to fill.



When the float valve operates for the first time, it may not close immediately, causing the break tank to overfill. Once the internals of the valve have been fully wetted this should not occur again.

2. Bleeding Pumps



Make sure that the internal isolation valve (combined equipment only) within the pressurisation unit is closed by following the steps below. Failure to do this may cause injury or damage to the equipment, system or property.

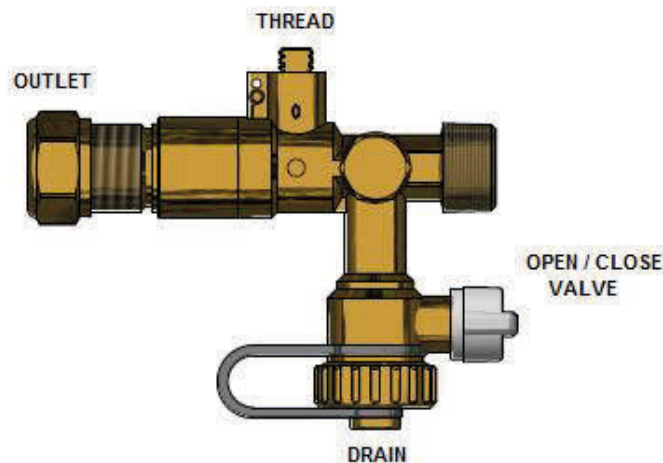

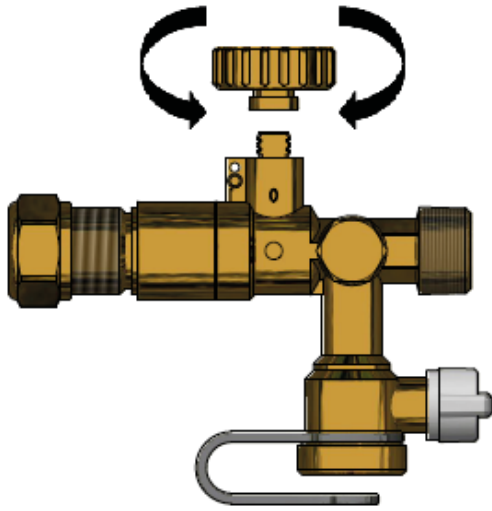

Procedure:

1. Unscrew cap from the drain valve
2. Place cap on thread
3. Twist cap clockwise to close valve from system
4. Place a hose over the drain connection
5. Open the valve to drain
6. Close the drain valve
7. Take off hose from drain valve
- 6 Twist cap anti-clockwise to open valve to system
7. Place cap back on the drain connection

Attach a length of hose to the drain and open the valve to the system. Remember to close valve once this is completed

Locate the bleed screw on the pump. The following diagrams show examples of typical bleed screw locations for most pumps:

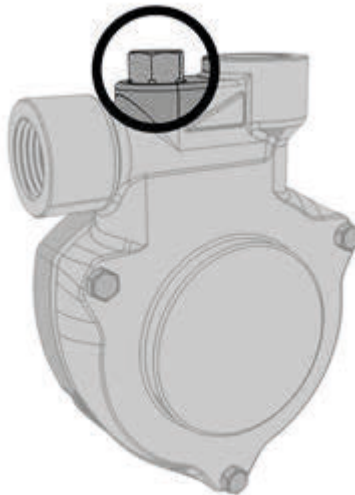

Do not use excessive force when tightening the bleed screw as this may damage the pump casing.



If the pump has a plastic bleed screw like the one shown below, do not use excessive force or attempt to use any tools to turn it as this may irreparably damage the pump casing.

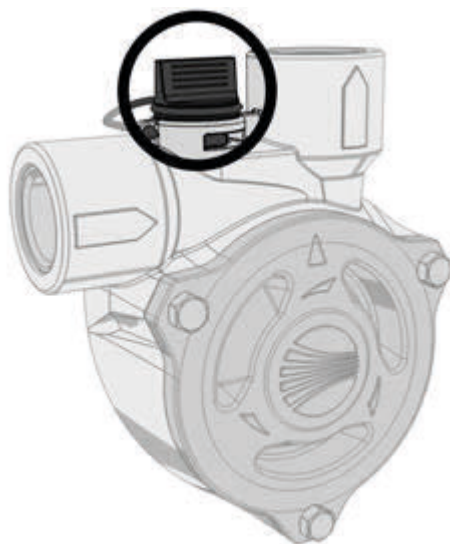

3. Forcing Pumps to Run



Turn on the power supply to the digital controller and wait for the system pressure to appear on the display. Then, enter the code 2601, Language menu will appear as default [E]. Press and hold (MUTE) & (+) for pump 1 to run and Press and hold (MUTE) & (-) for pump 2 to run

Key: (MUTE) & (+) = Pump 1 Run
(MUTE) & (-) = Pump 2 Run



To bleed the pumps, the pumps must be started. Then while the pump is running, the bleed screw must be opened until all the air has been removed and only water is being discharged. The bleed screw can then be closed.



Failure to bleed the pumps may result in damage to the equipment, system and property.



After bleeding the pumps, close the drain valve and remove the hose from the hose tail.

4. Venting the vacuum cylinder

Check the red cap on the air intake preventer is finger tight.



Do not unscrew the red cap completely. Inside is a glass bead and spring that prevent air being drawn into the equipment at this point. Without the spring and the beads this device will not function correctly, and the equipment as a whole will be unusable.

With the equipment electrically powered down remove the coil from the two Inlet solenoids

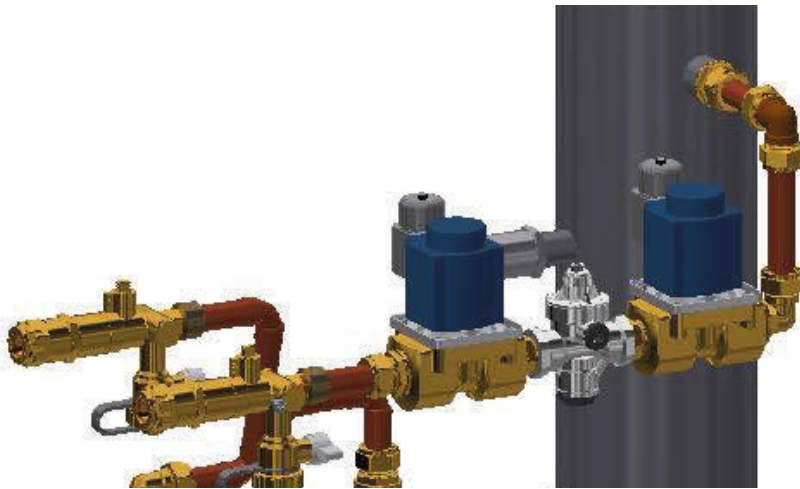

Be careful not to mix up the coils when disconnected. Failure to pair the correct coil with the correct valve will stop the unit from working.

With the coils disconnected use a pair of Danfoss override magnets (not supplied, available from Danfoss stockists under the 018F0091 part number) to manually open both of the solenoid valves. This allows the existing system pressure to fill the vacuum cylinder for the first run.

Remove the override magnets, return the correct coil to the correct valve and electrically switch the unit on. If the pressure shown on the degasser display is below the start pressure of the equipment it may be necessary to adjust the pressure reducing valve in between the two inlet solenoids. A setting on the pressure reducing valve 0.2 to 0.4 bar higher than the start pressure is acceptable, any lower than this and the equipment may become intermittent in operation.



If the Danfoss magnets are not available then it is possible to vent the cylinder through the internal 1 mm bypass, although this may take a considerable amount of time. The alternative to this is to temporarily put live power directly to the solenoid coils to force the valves to open.

5. Testing

To test the operation of the pressurisation unit while connected to the system, the system pressure must be lowered slowly to simulate a minor leak.

This can be achieved by using a drain point on the system, the drain point on the pressurisation unit, or by manually opening the safety relief valve.



Care must be taken not to let the pressure drop too quickly. If the system pressure falls below the low pressure set point, a low pressure fault will be displayed and the pumps will not run. The pressurisation unit is not designed to cope with a sudden loss of system pressure, which would be symptomatic of a catastrophic failure such as a burst pipe.

Once the system pressure has fallen below the cold fill setting (by an amount equal to the differential setting), the pump should start refilling the system. The pump will continue to run until the cold fill pressure has been reached.

This test demonstrates the primary function of the pressurisation unit. This test may be repeated at any time to confirm the operation of the pressurisation unit.

Operation

Once commissioned, the pressurisation unit should operate without any user intervention.

Under normal operating conditions, the display will show the current system pressure in Bar.

While the unit is filling, the display will show <PUMP 1 RUN> or <PUMP 2 RUN> depending on which pump is currently running.

If the unit identifies a fault, the display will show the relevant fault code.



If the pressurisation unit is showing a fault code on the display, holding down the [SET] button will cause the current system pressure to be temporarily shown on the display.

Fault Codes

The following table gives the meanings of all fault codes used on the digital controller:

Fault code	Description	Auto/Manual Reset
Low H2O	The break-tank low level float switch has been activated	Auto Reset
High H2O	The break-tank high level float switch has been activated	Auto Reset
Hw Communication Error	Communication between controller and expansion board not registering	Manual Reset
Pressure Sensor Fail	System pressure not registering and may have failed	Manual Reset
Degas Sensor Fail	Pressure within the cylinder not registering and may have failed	Manual Reset
Excessive Demand	There have been 4 pump starts within an 8 hour period	Manual Reset
Flood Limit	The respective pump has run for longer than the [FLOOD LIMIT] period	Manual Reset
Pump Timeout	Excessive high demand of water been pumped	Manual Reset
High Pressure Alarm	The system pressure is above the [HIGH PRESSURE] set point.	Auto Reset
Low Pressure Alarm	The system pressure is below the [LOW PRESSURE] set point.	Auto Reset
Pump1 Failure	The controller has detected a fault (incorrect current draw) on the respective pump	Manual Reset
Pump2 Failure		
All Pumps Failure	All pumps not making up pressure on system	Replace pump
Insufficient Vacuum	The low water switch has been activated, either a leak has occurred or the air non- return valve has failed or is missing.	Manual Reset
Degassing Pump Failure	Pump not reaching the require pressure within degassing mode	Manual Reset
Vac Cylinder high Pressure	Cylinder pressure alarm reached	Manual Reset
Stabilization Timeout	Either the pumps have run for too long or the pressure has not reached the required start pressure for the pump within the time limit.	Manual Reset

Fault code	Description	Auto/Manual Reset
Low Additive	Additive tank is low	Auto Reset
Low Pressure Warning	The system pressure is below the [LOW PRESSURE] set point.	Auto Reset
High Pressure Warning	The system pressure is above the [HIGH PRESSURE] set point.	Auto Reset
Maintain Pump1	Lifetime usage of pump has been reached	Replace pump
Maintain Pump2		
Service	The pressurisation unit is due an annual service	Manual Reset
Reset Required	Unit need to be restarted	Manual Reset



For practical guidance on diagnosing and rectifying faults, please refer to the Troubleshooting section of this manual.

Shutdown procedure



The pressurisation unit must be shut-down during any of the following scenarios:

- Work is being carried out on the system.
- Work is being carried out on the pressurisation unit
- The heating/cooling system is being flushed

To shut down the pressurisation unit, please follow the steps below:

1. Isolate the electrical power supply to the pressurisation unit
2. Isolate the mains water supply to the pressurisation unit
3. Isolate the pressurisation unit from the system using the isolation valve
4. If it is anticipated that the unit will be out of commission for more than 24 hours, it is advisable to drain the water from the break tank.

Start-up Procedure



Attention – This procedure is for restarting the unit after being shutdown (as described above). For initial start-up and commissioning procedures, please refer to the Commissioning section of this manual.

To restart the pressurisation unit, please follow the steps below:

1. Perform a visual inspection of the unit and installation to check for signs of damage
2. Check the break-tank for debris/deposits and remove if necessary
3. Turn on the mains water supply to the pressurisation unit and allow the break tank to fill
4. Open the isolation valve
5. Turn on the mains power supply and wait for the controller to start
6. Depending on the conditions in the system, the unit may display one or more fault codes at this point. If this happens, please refer to the Troubleshooting section of this manual for guidance.

Maintenance

Due to variations in operating conditions, and the varying loads placed on pressurisation units, it is not feasible to provide accurate predictions of component lifespan. The most effective method of maintenance is to inspect the pressurisation unit for early signs of component failure and take action accordingly.

The following maintenance procedures should be performed at least once a year:

Visual Inspection

A basic visual inspection will highlight the majority of potential faults on a pressurisation unit. It is recommended to perform a visual inspection annually. However, due to the simplicity of performing these checks, frequent inspections are encouraged.

- Check the digital display for fault codes
- Check for signs of leakage (e.g. water, mineral deposits, corroded components/cabinet)
- Check the break tank overflow for signs of water discharge
- Check flexible hoses for signs of degradation (e.g. cracks)
- Check that the pressure reading on the digital display corresponds to the actual system pressure (read off another gauge)

Interrogate Controller

The digital controller keeps a log of the number of pump starts and total hours run for each pump, as well as the number of alarm activations and power interruptions. It is advisable to take a note of these figures when servicing the unit, as they may be helpful in diagnosing potential issues. Fields are provided in the service log for these figures.

It is advisable to scroll through all the settings (including engineers setting) and check them against the figures on the commissioning report. If there are any discrepancies, check first with on-site staff to see if the changes are deliberate. If not, reconfigure appropriately.



If settings are persistently becoming corrupted, a power filter may be required. Please refer to the Installation section of this manual for more information.

Test Unit Operation

The best way to test the operation of the pressurisation unit is to drain water from the system, allowing the pressure to drop slowly. Once the pressure falls below the pump cut-in pressure ([COLD FILL] - [DIFFERENTIAL]) the pump should start. As soon as the pump starts, close the drain point and allow the system pressure to rise. Once the [COLD FILL] pressure is reached, the pump should stop.

If the unit is a twin pump model, this test should be repeated until both pumps have run and successfully re-pressurised the system.

Check Float Valve Operation

To test the operation of the break tank float valve, first ensure that the break tank overflow has a suitable path to drain.

Gently push down on the arm of the float valve until it starts to discharge water, then release the float valve arm.

Once the arm has been released, the flow of water should stop within a few seconds.

Check Float Switch Operation

To test the operation of the break tank low level float switch, reach into the break tank and gently push the float switch down into the horizontal position.

The digital controller should now display a <LOW H2O> fault.

Release the float switch and observe the display. The fault should clear after a delay of a few seconds.

Check Break Tank Water Condition

Perform a visual check of the water in the break tank. If there is any dirt or debris in the water, or deposits on the sides of the tank, the tank should be drained down and cleaned.

Check Strainer

Topup units are fitted with a mesh strainer in the connection at the bottom of the break tank. This should be removed and inspected. Depending on the condition, this part may need to be cleaned or replaced.

Check PRV Strainer

Flexfiller pressurisation units are fitted with a mesh strainer in the connection at the bottom of the break tank. This should be removed and inspected. Depending on the condition, this part may need to be cleaned or replaced.

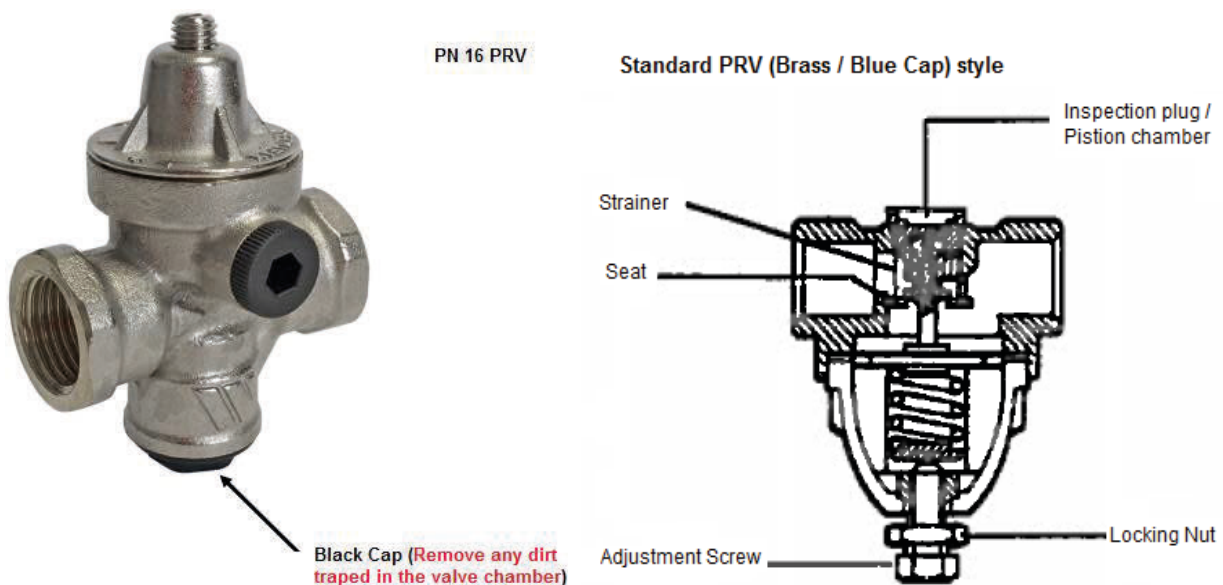

Check Expansion Vessel Pre-Charge

Many of the problems experienced with pressurisation equipment can be traced back to the expansion vessel.

The expansion vessel pre-charge pressure must be checked after 1 years and annually thereafter.

To perform this test, the expansion vessel must first be isolated and drained of water, then a gauge can be connected to the Schrader valve on the vessel to measure the pre-charge pressure. The pre-charge should be equal to the [COLD FILL] pressure setting.

On potable vessels there may be already a pressure gauge indicating the pressure.

The pressure can be increased using a foot pump, air compressor or pressurised air/nitrogen cylinder.



If any faults are identified during these checks, please refer to the Troubleshooting section of this manual. If replacement parts are required, please refer to the Spares section for part codes.

Wiring

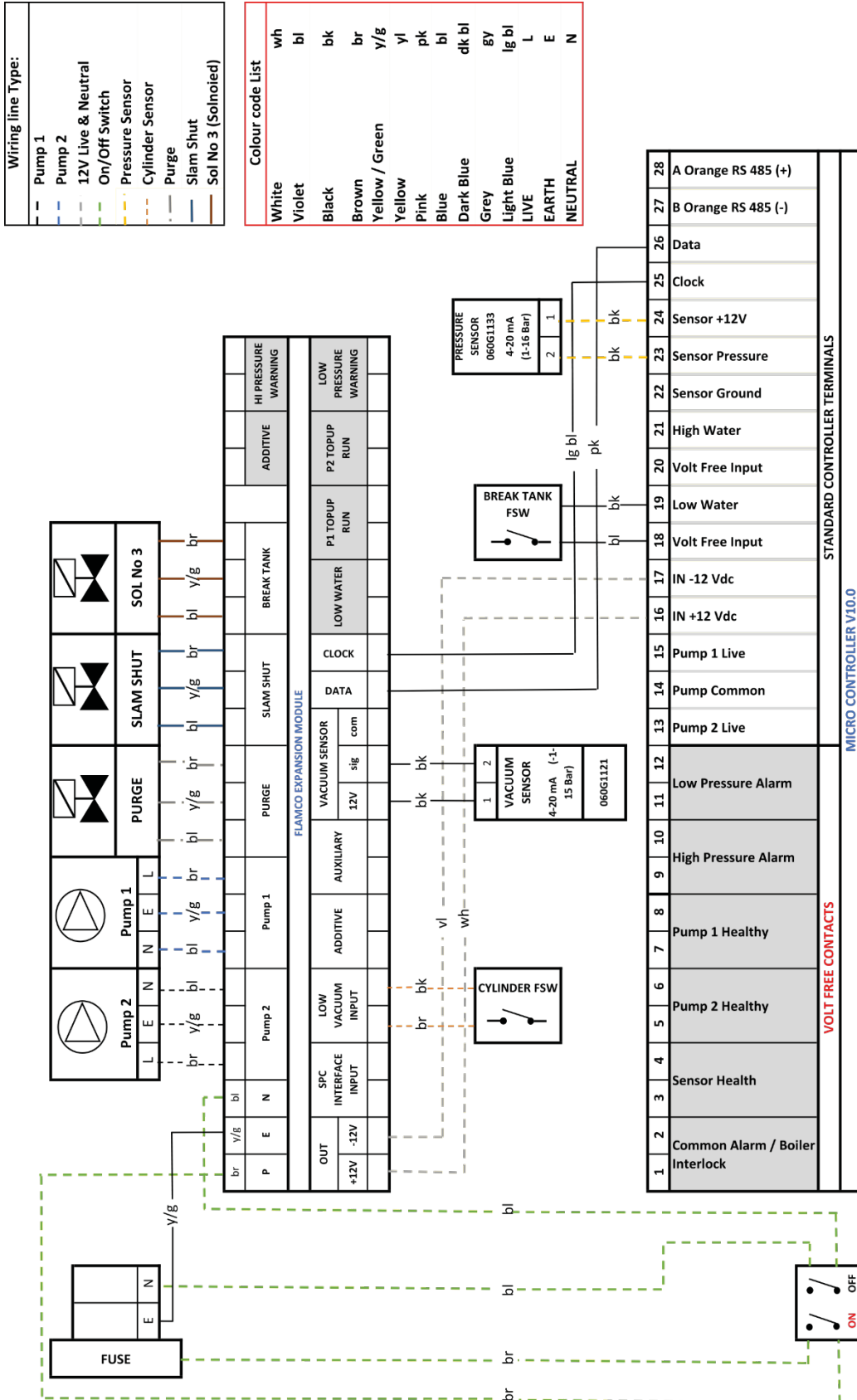

Troubleshooting

If for any reason the pressurisation unit does not seem to be functioning correctly, please refer to the table below for a list of solutions to known problems.



If the pressurisation unit is showing a fault code on the display, holding down the [SET] button will cause the current system pressure to be temporarily shown on the display.

Symptom	Problem	Solution
LOW PRESSURE fault is displayed and the pumps do not run	The internal isolation valve within the unit is closed	Open the internal isolation valve
	The system pressure has fallen below the LOW PRESSURE set point	Increase system pressure using a filling loop, or enable the SYSTEM FILL option
	The SPC CONTROLLER option is enabled	Disable the SPC CONTROLLER option
	The LOW PRESSURE set point is too high	Review the system specifications
HIGH PRESSURE fault is displayed	The internal isolation valve within the unit is closed	Open the internal isolation valve
	The system pressure has risen above the HIGH PRESSURE set point	Decrease system pressure using a suitable drain point
	The expansion vessel has failed or lost its pre-charge	Check the expansion vessel pre-charge and re-charge if necessary
	The expansion vessel is undersized	Review the expansion vessel selection
	The HIGH PRESSURE set point is too low	Review the system specifications
FLOOD LIMIT is displayed	A large amount of water has been lost from the system	Investigate cause
	The relevant pump is air-locked and not pumping water	Bleed the pump
	The unit is undersized for the system	Review unit selection
	The FLOOD LIMIT time is too short.	Consult Armstrong

Symptom	Problem	Solution
Pump1 and/or Pump2 Failure is displayed	The PUMP TYPE option is set incorrectly.	Review PUMP TYPE setting
	The relevant pump has failed	Replace pump
Pump2 Failure is displayed but the unit is a single pump model	The PUMPS NUMBER option is incorrectly set to 2	Set PUMPS NUMBER to 1
LOW H2O fault is displayed	The mains water supply to the unit has been isolated	Turn on the mains water supply
	The mains pressure is poor	The fault will clear once the break tank has been re-filled
	A non-standard electrical connection has been made into terminals 19 & 20	Remove all non-standard electrical connections
	The low water float switch has failed	Replace low water float switch
	The digital controller has failed	Replace digital controller
HIGH H2O fault is displayed	A non-standard electrical connection has been made into terminals 21 & 22	Remove all non-standard electrical connections
	The digital controller has failed	Replace digital controller
Pressure reading does not match actual system pressure.	The internal isolation valve within the unit is closed	Open the internal isolation valve
	The SENSOR TYPE option is set incorrectly	Review SENSOR TYPE setting
	A non-return valve has been installed between the unit and the system	Remove non-return valve
	The pressure sensor has failed	Replace pressure sensor
Pump runs but does not make up pressure	The pump is air-locked and not pumping water	Bleed the pump
The pump is persistently becoming air-locked	The wrong/no flow restrictor is installed in the float valve (mini and midi units only)	Check float valve flow restrictor selection (mini and midi units only)
Hw Communication Error	Communication between controller and expansion board not registering	Check wiring between DATA & CLOCK
Pressure Sensor Fail	System pressure not registering correctly	Check voltage between 24 & 22
	System pressure showing higher pressure than installation pressure	Check settings
Degas Sensor Fail	Cylinder pressure not detected	Check voltage between VACUUM SENSOR 12V and -12Vdc
	Cylinder pressure showing higher pressure than was should be	Check settings

Symptom	Problem	Solution
The break tank is overflowing and discharging water to drain or over the weir	The wrong/no flow restrictor is installed in the float valve (mini and midi units only)	Check float valve flow restrictor selection (mini and midi units only)
	The float valve position is set incorrectly	Set the float valve to its lowest possible position
	The float valve has failed	Replace float valve
	A pump non-return valve has failed	Replace non-return valve
The pump is repeatedly running in short bursts	The internal isolation valve within the unit is partially closed	Fully open the internal isolation valve
	The restriction in the connecting pipe work is too great	Increase bore/ reduce number of bends/ reduce length of connecting pipe work
	A pump non-return valve has failed	Replace non-return valve
	The expansion vessel has failed or lost its pre-charge	Check the expansion vessel pre-charge and re-charge if necessary
	The point of connection of the unit is too far away from the expansion vessel	Move unit/expansion vessel connection points closer together.
The buttons on the digital controller do not respond	The plastic housing of the digital controller has come apart and the PCB has moved	Reassemble the digital controller housing and ensure that the PCB is properly seated
The digital controller parameters are being corrupted	The controller is being subject to power spikes	Fit a suitable power filter
The digital controller does not power up when the unit is switched on	The fuse has blown	Replace the fuse
	The mains power supply is at an incorrect voltage or frequency	Check mains power supply
	The 12V transformer has failed	Replace Transformer
	The digital controller has failed	Replace digital controller
SERVICE is displayed on the screen	The unit is due an annual service	Contact service engineer

Symptom	Problem	Solution
Vac Cylinder High Pressure	The internal pressure within the vacuum cylinder has reached the high pressure alarm limit, probably due to the pressure reducing valve being contaminated with debris.	The safety solenoid valve will automatically close and the system will attempt to self-reset during the next degassing cycle. Repeated High pressure alarms will require the pressure reducing valve to be inspected and cleaned.
Insufficient Vacuum	The Vacuum cylinder is full of air and the low-level switch is stopping further pump activation to prevent the pump(s) running dry. There is an air leak on the cylinder, the bypass solenoid is contaminated with debris or the air intake preventer is contaminated with debris	Clean the air intake preventer, and test the unit. If this fails then check the bypass solenoid and pipework for contamination. Finally replacing the automatic air vent assembly is the best course of action.
Stabilization Timeout	The vacuum cylinder has not been able to return to the start pressure in the allotted time	Check the bypass solenoid valve is not blocked (1 mm bypass hole), replace if required. Check the setting on the pressure reducing valve and the internal filter of the pressure reducing valve.
Stabilization Timeout	The required vacuum has not been generated in the allotted time	Check the pump operation and that the system pressure is within the operational pressures of the equipment. Replace the Pump as required.
		Check the bypass solenoid is functioning correctly and closing after the purge cycle.
All Pumps Failure	Pumps have failed and not making up pressure	Replace pump
	The PUMP TYPE option is set incorrectly.	Review PUMP TYPE setting
	The relevant pump has failed	Replace pump
Maintain Pump1	Pump are at an end of the lifetime usage and need replacing	Replace pump
Maintain Pump2		

Warranty Details

Warranty - What Is Covered?

The Armstrong warranty on equipment supplied to distribution and OEM covers manufacturing defects, under our standard terms and conditions of sale.

If the unit is identified with a manufacturing defect then no charge is made for correcting the defect.

The 3760 equipment is manufactured to order and is clearly marked, where applicable, with a unique serial number, allowing traceability to both individual model configuration and the engineer or site responsible for the build and test.

Warranty - What Is Not Covered?

If a defect or problem has arisen as a direct result of the connected system, misuse, incorrect handling, incorrect installation or incorrect commissioning then any service visit is chargeable.

If a defect is identified as a manufacturing defect it will be addressed as described above, additional remedial works as a result of misuse, incorrect handling, incorrect installation or incorrect commissioning then the additional work is chargeable.

Installation costs and/or consequential losses are not covered by this agreement.

Conditions of warranty

DOS - Date of Supply

DOC - Date of Commissioning

Equipment	Conditions	Timescale
3760 Combine Pressurisation Equipment	That there is an appropriate safety valve on the system protecting the equipment. That the equipment is undamaged at the time of installation. That the equipment is not exposed to adverse environmental conditions. That the equipment is stored and installed in a frost-free area. That the operating and maintenance instructions are followed. That the equipment is used for the purpose for which it was designed.	18 months DOS 24 months DOC

Contact Details

Please send form back this form using the address below, if you any queries please use contact below.

Phone: +44 (0)161 233 2333

Email: ukhvacsales@armstrongfluidtechnology.com (General Enquires)

Email: ukservice@armstrongfluidtechnology.com (Service Enquires)

Statement of compliance

Supplier: Armstrong Fluid Technology
1 Wolverton Street
Manchester
M11 2ET
United Kingdom

Product: 3760 Pressurisation Equipment

Description: Sealed system pressurisation equipment, dosing equipment and combinations thereof.

Statement:

The above-mentioned products are manufactured in The UK and comply with the essential requirements of the applicable directives, including but not limited to:

Pressure Equipment Directive	2014/68/EU
Sound Engineering Practice	
RoHS Compliance	

Additional Information:

All appropriate components bear the CE mark prior to assembly, and are bound by their individual applicable directives including but not limited to:

Pressure Equipment Directive	2014/68/EU
Low Voltage Directive	2014/35/EU
Electromagnetic Compatibility Directive	2014/30/EU
Machinery Directive	2006/42/EC

CE Marking:

Under the regulations and guidelines CE marking of the assembled pressurisation unit is not permitted.

TORONTO

23 BERTRAND AVENUE,
TORONTO, ONTARIO,
CANADA, M1L 2P3
+1 416 755 2291

BUFFALO

93 EAST AVENUE, NORTH
TONAWANDA, NEW YORK,
U.S.A., 14120-6594
+1 716 693 8813

DROITWICH SPA

POINTON WAY, STONEBRIDGE CROSS
BUSINESS PARK, DROITWICH SPA,
WORCESTERSHIRE,
UNITED KINGDOM, WR9 0LW
+44 121 550 5333

MANCHESTER

WOLVERTON STREET, MANCHESTER
UNITED KINGDOM, M11 2ET
+44 161 223 2223

BANGALORE

#18, LEWIS WORKSPACE, 3RD FLOOR,
OFF MILLERS - NANDIDURGA ROAD,
JAYAMAHAL CBD, BENSON TOWN,
BANGALORE, INDIA 560 046
+91 80 4906 3555

SHANGHAI

UNIT 903, 888 NORTH SICHUAN RD.
HONGKOU DISTRICT, SHANGHAI
CHINA, 200085
+86 21 5237 0909

BEIJING

ROOM 1612, NANYIN BUILDING NO.2
NORTH EAST THRID RING ROAD
CHAOYANG DISTRICT, BEIJING,
CHINA 100027
+86 21 5237 0909

SÃO PAULO

RUA JOSÉ SEMIÃO RODRIGUES
AGOSTINHO, 1370 GALPÃO 6 EMBU
DAS ARTES, SAO PAULO, BRAZIL
+55 11 4785 1330

LYON

93 RUE DE LA VILLETTE
LYON, 69003 FRANCE
+33 4 26 83 78 74

DUBAI

JAFZA VIEW 19, OFFICE 402
P.O. BOX 18226 JAFZA,
DUBAI - UNITED ARAB EMIRATES
+971 4 887 6775

JIMBOLIA

STR CALEA MOTILOR NR. 2C
JIMBOLIA 305400, JUD.TIMIS
ROMANIA
+40 256 360 030

For further information on the 3760 Pressurisation unit range
or to download individual product data sheets please visit:



[www.armstrongfluidtechnology.com/en-gb/
products-and-services/heating-and-cooling/
pressurisation-units](http://www.armstrongfluidtechnology.com/en-gb/products-and-services/heating-and-cooling/pressurisation-units)