

Design Envelope — 4300 & 4380

Vertical in-line pumping
unit with integrated
controls

Installation and operating instructions

File No: 94.81 EU
Date: NOVEMBER 20, 2023
Supersedes: 94.81 EU
Date: SEPTEMBER 12, 2017

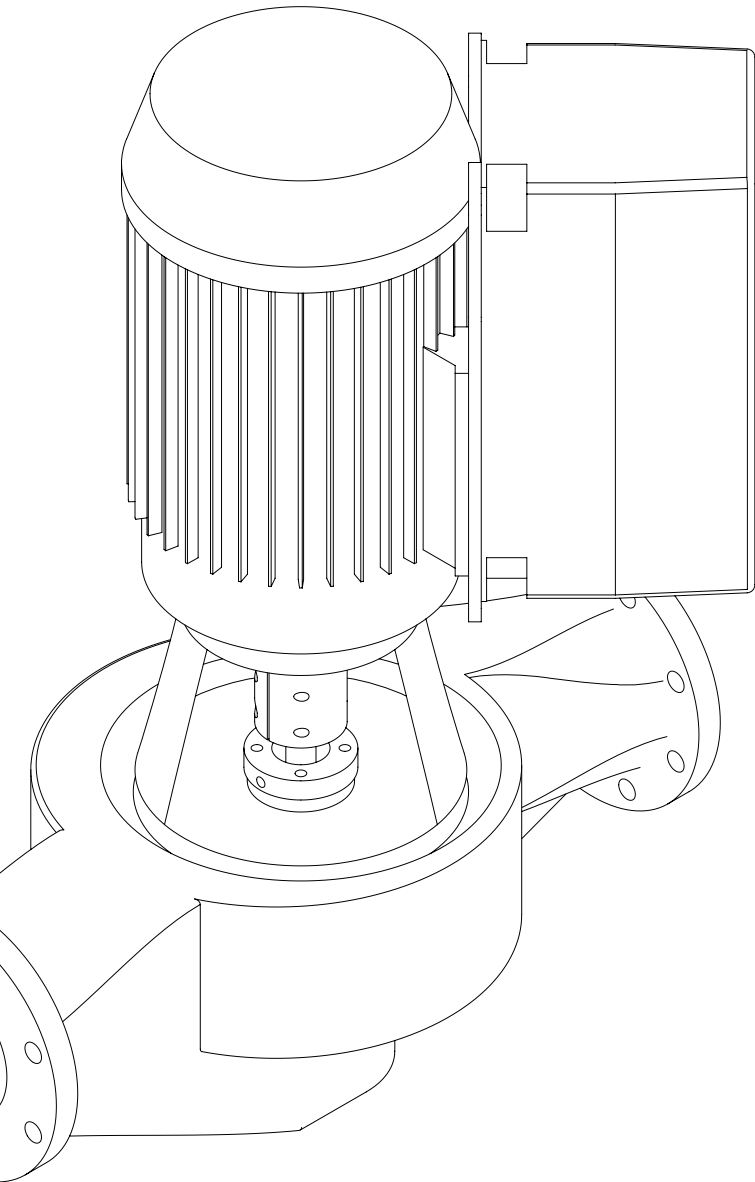

CONTENTS

1.0	Introduction	4
1.1	Instructions for safe use	4
1.2	Temperature	4
1.3	Noise levels	4
1.4	Vibration levels	5
1.5	Storage	5
1.6	Uncrating	5
1.7	Handling Design Envelope 4300 & 4380 units	5
2.0	Installation	6
2.1	Location	6
2.2	Installation	6
2.3	Pump piping - general	7
2.4	Alignment	8
2.5	Starting pump	8
2.6	General care	8
2.7	Lubrication	9
2.8	System cleanliness	9
3.0	CE conformities	13
4.0	Mechanical installation	13
4.1	Enclosure rating	13
4.2	Ambient temperature	13
5.0	Electrical installation	13
5.1	Earth leakage current	14
5.2	Earth leakage current	14
5.3	Additional motor protection	14
5.4	Supply voltage	14
5.5	Tools for installation	14
5.6	Cable entry sizes	14
5.7	Max. cable cross section	14
5.8	Mains supply connection	15
5.9	Max. cable cross section	15

	5.9.1	Connection examples	16					
6.0		Programming, monitoring and diagnostics	17		11.7	Relay connections	35	
	6.1	LCP functions and operation	18		11.8	Connection tightening torques	36	
		6.1.1 Display	18			11.8.1	Torques settings (1.1-90kW drives)	36
		6.1.2 LED'S	18			11.8.2	Torques settings (>90kW drives)	37
		6.1.3 Control keys	18		11.9	Electrical installation and control connections	38	
		6.1.4 Display mode	19			11.9.1	Access to terminals	39
		6.1.5 Quick menu	20			11.9.2	Control terminals	39
		6.1.6 Menu mode	20			11.9.3	Connection examples	40
7.0		Sensorless operation	23			11.9.4	Remote LCP keypad wiring	41
	7.1	Default operating mode - quadratic pressure control	23		12.0	Programming, monitoring and diagnostics	42	
		7.1.1 Description of settings	23			12.1	GLCP functions and operation	42
		7.1.2 setting parameters for quadratic pressure control	23			12.2	Indicator lights (LEDS)	43
	7.2	Constant pressure control	23			12.3	Control keys	43
		7.2.1 Setting parameters for constant pressure control	24			12.4	Programming	44
	7.3	Proportional pressure control	24			12.4.1	Parameter selection	44
		7.3.1 Setting parameters for proportional pressure control	24			12.4.2	Changing data	45
8.0		Control using external feedback	24		13.0	Sensorless operation	45	
	8.1	Parameter groups and descriptions.	24			13.1	Default operating mode — quadratic pressure control	45
9.0		Warnings and alarms	29			13.1.1	Settings for quadratic (control curve) pressure control	46
	9.1	Internal led descriptions	30			13.2	Constant pressure control	46
10.0		Integrated controls	33			13.2.1	Settings for constant pressure control	46
	10.1	Enclosure rating	33			13.3	Changing control modes	46
	10.2	Ambient temperature	33			13.3.1	Change to external sensor control	46
11.0		Electrical installation	33			13.3.2	Change to open loop (BAS) control	46
	11.1	Ground leakage current	33			13.3.3	Change to sensorless control	47
	11.2	Start / stop of pump	33		14.0	Warnings and alarms	47	
	11.3	Additional motor protection	33			14.1	Fault messages	48
	11.4	Supply voltage	33		15.0	Acoustic noise and vibration	50	
	11.5	Supply fusing	34					
	11.6	Grounding and it mains	34					

1.0 INTRODUCTION

This document contains specific information regarding the safe installation, operating and maintenance of the Armstrong Design Envelope pumps and should be read and understood by installing, operating and maintenance personnel. The equipment supplied has been designed and constructed to be safe and without risk to health and safety when properly installed, operated and maintained. The instructions following must be strictly adhered to. If clarification is needed on any point please contact Armstrong quoting the equipment serial number.

1.1 INSTRUCTIONS FOR SAFE USE



No installation of this equipment should take place unless this document has been studied and understood. Handling, transportation and installation of this equipment should only undertaken by trained personnel with proper use of lifting equipment. See later diagrams for lifting advice. Refer to the pump nameplate for pump speed, pressure and temperature limitations. The limits stated must not be exceeded without written permission from Armstrong.

1.2 TEMPERATURE



Install the Design Envelope unit with adequate access for routine maintenance. Adequate space, particularly at the fan inlet 2" (50 mm), is necessary to facilitate airflow. Where several Design Envelope units are installed in close proximity, care must be taken to ensure that there is no re-circulation of exhausted warm air.

Where under normal operating conditions the limit of 68°C/155°F (Restricted Zone) for normal touch, or 80°C/176°F (Unrestricted Zone) for unintentional touch, may be experienced, steps should be taken to minimize contact or warn operators/users that normal operating conditions will be exceeded. In certain cases where the temperature of the pumped liquid exceeds the above stated temperature levels, pump casing temperatures may exceed 100°C/212°F and not withstanding pump insulation techniques appropriate measures must be taken to minimize risk for operating personnel. The ambient temperature for standard motors must be no greater than 40°C/104°F.

1.3 NOISE LEVELS

Typical Pumping Unit Sound Pressure Level, Decibels, A-Weighted, at 1 m (3 ft.) from unit.

FRAME DESIGNATION	1500 RPM				3000 RPM			
	FCM		TEFC		FCM		TEFC	
	kW	db-A	kW	db-A	kW	db-A	kW	db-A
80	0.55-0.75	55	0.55-0.75	47	0.55-0.75	55	0.55-1.1	58
90	1.1-1.5	60	1.1-1.5	49	1.1-1.5	60	1.5-2.2	62
100	2.2	59	2.2	53	2.2	59		
100	3	62	3	53	3	62	3	64
112	4	64	4	54	4	63	4	66
132	5.5-7.5	62	5.5-7.5	60	5.5-7.5	62	5.5-7.5	69
160			11-15	63			11-18.5	74
180			18.5-22	65			22	75
200			30	65			30-37	78
225			37-45	66			45	78
250			55	67			55	81
280			75-90	70			75-90	81
315			110-132	78			110-132	82
315			160-200	83			160-200	86
355			250-315	85			250-315	89

1.4 VIBRATION LEVELS

Armstrong Vertical In-Line pumps are designed to meet vibration levels set by Hydraulic Institute Standard hi Pump Vibration 9.6.4. Standard levels are as detailed below:

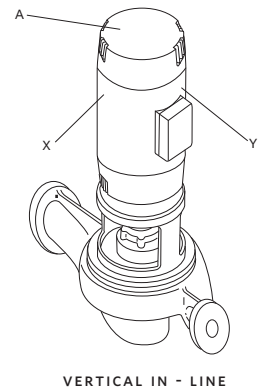
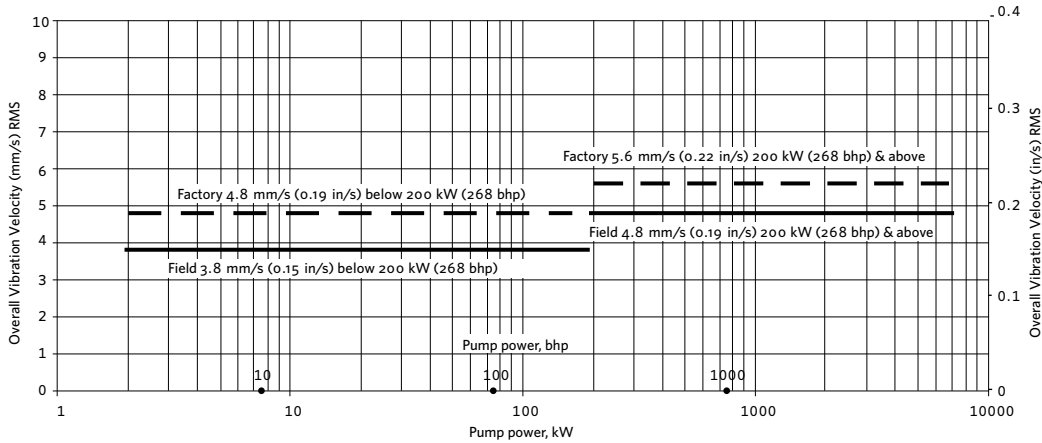

1.5 STORAGE

Pumps not immediately placed into service, or removed from service and stored, must be properly prepared to prevent excessive rusting. Pump port protection plates must not be removed until the pump is ready to connect to the piping.

Rotate the shaft periodically (at least monthly) to keep rotating element free and bearings fully functional.

For long term storage (longer than three months), the pump must be placed in a vertical position in a dry environment.

Internal rusting can be prevented by removing the plugs at the top and bottom of the casing and drain or air blow out all water to prevent rust buildup or the possibility of freezing. Be sure to reinstall the plugs when the unit is made operational. Rustproofing or packing the casing with moisture absorbing material and covering the flanges is acceptable. When returning to service be sure to remove the drying agent from the pump.

1.6 UNCRATING

Armstrong Vertical In-Line pumps are thoroughly inspected before shipment to assure they meet with your order requirements. After removing the pump from the crate, make sure the equipment is in good order and that all components are received as called for on the packing list. Any shortages or damage should be reported immediately. Use extreme care in handling the unit, placing slings and hooks carefully so that stress will not be imposed on the integrated controls, pump or motor. **Never place cable slings around the pump shaft or integrated controls.** The eye bolts or lifting lugs on the motor are intended for lifting only the motor and not the complete unit.

1.7 HANDLING DESIGN ENVELOPE 4300 & 4380 UNITS

To handle Design Envelope 4300 and 4380 units from shipment, secure the pallet following uncovering the unit, then place straps behind the integrated controls (around the motor feet) and carefully lift the pumping unit to stand the pump vertically upright. Lift only sufficiently to remove the pallet, then lower onto a flat surface. The pump and motor unit will free-stand on the casing ribs. Extra care is required to ensure the integrated controls do not get damaged during lifting and installation.

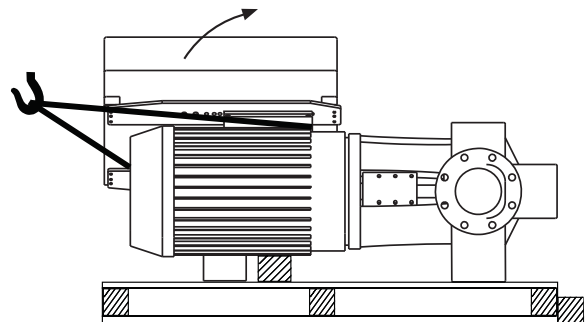

For Design Envelope 4300 units, remove the coupling guard and insert lifting straps through the pump/motor pedestal on either side of the coupling. For Design Envelope 4380 units, remove the motor eye-bolt and install a swivel hoist ring tied to a lifting strap. Place secondary lifting straps around the motor feet (and/or spacers). As the lifting device is engaged (Using a spacer bar if necessary) and the straps tighten ensure no part of the strapping is touching any part of the control or motor fan cover. Lift the pumping unit carefully from the pallet in this manner and allow the unit to stand upright on a flat surface and re-position the straps, if necessary, to ensure safe and damage-free transportation into the pipe installation.



Remove coupling guard and place lifting straps on each side of coupling, use spacer bar if necessary to protect the integrated controls and motor fan cover.

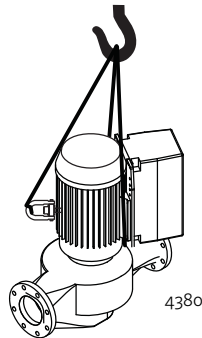

Remove the motor eye-bolt and install a swivel hoist ring tied to a lifting strap. Place secondary lifting straps securely around motor feet (and/or spacers).

IMPORTANT:



Do not run the pump for any length of time under very low flow conditions or with the discharge valve closed. To do so could cause the water in the casing to reach super heated steam conditions and will cause premature failure and could cause serious and dramatic damage to the pump and surrounding area.

2.0 INSTALLATION

2.1 LOCATION

In open systems, locate the unit as close as practical to the liquid being pumped, with a short, direct suction pipe. Ensure adequate space is left above and around the unit for operation, maintenance, service and inspection of parts.

In closed systems, where possible, the pumps should be installed immediately downstream of the expansion tank /make-up connection. This is the point of zero pressure change and is necessary for effective pump operation. Do not install more than one expansion tank connection into any closed hydronic system. Electric motor driven pumps should not be located in damp or dusty location without special protection.

Airflow into the motor and/or motor fan should not be obstructed.

2.2 INSTALLATION

When installing vertical in-line pumps, an important consideration to accrue full added-value from the pump design is to ensure that the pump is pipe-mounted and free to 'float' with any movement, expansion and contraction of the piping. Should any vertical in-line pump use supports to the structure it is imperative that no pipe strain is imposed on the pump flanges. Tell-tale pieces of equipment such as springs or 'waffle' style neoprene isolation pads that distort with pressure to indicate added piping weight, should be used under pump supports should the pump not be truly pipe mounted.

Design Envelope 4300 and 4380 cannot be mounted with shafts in the horizontal position.

Various installation arrangements are detailed on Pages 9-12 All Design Envelope 4300 pumps contain a tapped hole in the motor bracket above the discharge flange to drain condensate buildup of seal leakage. (FIG. 2.14)

2.2.1

Vertical In-Line pumps may be installed directly in the system piping with no additional support. Pipe hangers are simply sized for the additional weight of the pumping unit. Many pumps are installed in this manner and can be mounted at sufficient height to take zero floor space. (FIG. 2.1)

2.2.2

Piping in many mechanical rooms is hung close to the ceiling and larger pumps are mounted near ground level for ease of maintenance. FIG. 2.2 illustrates such an arrangement with the piping supported at the ceiling and the VIL unit installed with an Armstrong Suction Guide and Flo-Trex valve. Many very large VIL pumps are installed in this manner.

2.2.3

Should additional space saving be required the discharge spool piece may be replaced by a long-radius elbow.

2.2.4

FIG 2.4 illustrates a similar arrangement to FIG 2.2 with additional floor mounted pipe-stools isolated from the structure by 'waffle' style neoprene isolation pads under the Armstrong Suction Guide and Flo-Trex valve.

2.2.5

Floor mounted saddle supports (FIG. 2.5) are typical for condenser water pumps where cooling tower base is at the mechanical room elevation.

2.2.6

Where required, additional floor support may be used as shown in Fig. 2.6. Note that the pump should not be rigidly attached to the column. Leave a small gap between pump and column or install a 'waffle' isolation pad under the pump. It is critical that piping be installed in such a manner that the pump does not become a pipe support.

2.2.7

FIG. 2.7 illustrates stanchion plates at the pump inlet and outlet ports that may be supplied for installation convenience. Isolation pads must be used under the legs and monitored as pipe hangers are adjusted to ensure the pump flanges are not supporting the piping. Bolting to the floor or housekeeping pad is not recommended. If the stanchions are bolted down the bolts must be isolated from the stanchion or an inertia base and flexible pipe connectors used.

2.2.8

FIG. 2.8 illustrates installations with stanchion plates for seismically active regions. Seismically rated isolation pads or snubbers with bolts isolated from the stanchion plates are installed to restrain the pump during a seismic event. Pipe hangers carry the weight of the equipment as seismic components are designed only to restrain the equipment during a seismic event.

2.2.9

Many Vertical In-Line pumps are piped successfully into grooved piping systems. In-line pumps are supported well by grooved piping however flange adapter locking devices or a welded flange at the pump should be used to prevent the possibility of pipe mounted pumps rotating in the piping. Armstrong offers grooved suction guides with cast-in outlet flanges and Flo-Trex valves with Armgrip™ fittings to prevent this possibility. (**FIG. 2.9**)

2.2.10

Do not support the unit by the motor eye bolts (**FIG. 2.10**) or by any other part of the motor.

2.2.11

Connecting the pump to a permanent rigid base (**FIG. 2.11**) is not recommended unless isolated from the piping by flexible connectors and the base isolated from the building structure on an inertia base. (**FIG. 2.11** is generally acceptable when using plastic piping).

2.2.12

The motor and integrated control assembly can be rotated in 90° increments to meet installation spacing requirements. Where applicable, remove the coupling guard to access the motor bolts. Remove the motor bolts to rotate the motor and integrated control assembly by hand. Larger motors may need strapping and slight lifting to break the contact with the pedestal. Care should be taken that the controls are not damaged during lifting and that the flushline, flushline accessories and the coupling guard removal/seal service window are not compromised following the turn (**FIG. 2.12**). VIL pumping units without integrated controls can also be rotated in a similar manner to facilitate access to the the motor terminal box.

2.2.13

For D1 and D2 chassis Design Envelope units (110 kW–315 kW), ensure adequate space is available for the access door to swing open. (**FIG. 2.13**)

IMPORTANT:

All Design Envelope 4300 pumps contain a tapped hole in the motor bracket above the discharge flange (see **FIG. 2.14**) for draining the well. Pipe this drain hole to a floor drain to avoid overflow of the cavity caused by collecting chilled water condensate or from seal failure.

2.3 PUMP PIPING - GENERAL

Never connect a pump to piping, unless extra care is taken to measure and align the piping flanges well. Always start piping from pump.

Use as few bends as possible and preferably long radius elbows. Do not use flexible connectors on the suction or discharge of a vertical in-line pump, unless the pump is rigidly mounted to a foundation.

Ensure piping exerts no strain on pump as this could distort the casing causing breakage or early failure due to pump misalignment.

All connecting pipe flanges must be square to the pipework and parallel to the pump flanges.

Suction and discharge pipes may be increased or decreased at pump nozzle to suit pump capacity and particular conditions of installation. Use eccentric reducers on suction connection with flat side uppermost.

Layout the suction line with a continual rise towards the pump without high points, thus eliminating possibility of air pockets that may prevent the pump from operating effectively.

A strainer of three or four times the area of the suction pipe, installed in the suction line, will prevent the entrance of foreign materials into the pump. 3/8" (3 mm) diameter perforations in the strainer is typical.

In open systems, test suction line for air leaks before starting; this becomes essential with long suction line or static lift.

Install, at the pump suction, a straight pipe of a length equivalent to four or six times its diameter; this becomes essential when handling liquids above 120°F (49°C). Armstrong suction guides may be used in place of the straight pipe run and in-line strainer.

Install an isolation valve in both suction and discharge lines on flooded suction application; these valves are used primarily to isolate the pump for inspection or repair.

Install a non-slam non-return check valve in discharge line between pump and isolation valve to protect pump from excessive back pressure and to prevent water running back through the pump in case of driver failure on open systems.

8

2.4 ALIGNMENT

Design Envelope 4300 units are accurately aligned at the factory prior to being shipped and do not need re-aligning when installed. Alignment on a Design Envelope 4300 unit may be verified by assuring an equal and parallel gap between coupling halves on both sides of the coupling.

OPERATION

2.5 STARTING PUMP



Ensure that the pump turns freely by hand, or with some gentle mechanical help such as a strap or Allen key in coupling bolt.

Ensure that all protective guarding is securely fixed in position.

The pump must be fully primed on start up. Fill the pump casing with liquid and rotate the shaft by hand to remove any air trapped in the impeller. On Design Envelope 4300 any air trapped in the casing as the system is filled must be removed by the manual air vent in the seal flush line. **Ensure entrained air is removed from Design Envelope 4300 pumps, prior to starting, through the air vent on the seal flush line. Open vent until clear of air.**

Design Envelope 4380 units are fitted with seal flush/vent lines piped to the pump suction area. When these units operate, residual air is drawn out of the pump towards the suction piping.

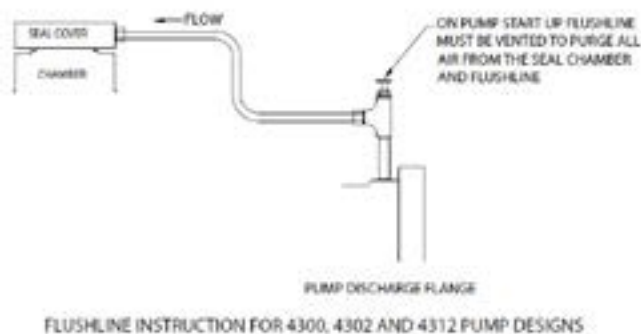

Bump or energize the motor momentarily and check that the rotation corresponds with the directional arrow on the pump casing (clockwise when viewed from drive end.).

Start the pump with the discharge valve closed and the suction valve open, then gradually open the discharge valve when the motor is at operating speed. The discharge valve may be **cracked** or open slightly at start up to help eliminate trapped air.

When stopping the pump: Close the discharge valve and de-energize the motor.

Do not run the pump against a closed discharge valve for an extended period of time (a few minutes maximum.)

Should the pump be noisy or vibrate on start-up a common reason is overstated system head. Check this by calculating the pump operating head by deducting the suction pressure gauge value from the discharge gauge reading. Convert the result into the units of the pump head as stated on the pump nameplate and compare the values. The system designer or operator should be made aware of this soon as some adjustment may be required to the drive settings to make the pump suitable for the system as installed.



Check rotation arrow prior to operating the unit. The rotation of all Armstrong Vertical In-Line units is "clockwise" when viewed from the drive end. (Looking from on top of/behind the motor).

2.6 GENERAL CARE

Vertical In-Line pumps are built to operate without periodic maintenance, other than motor lubrication on larger units. A systematic inspection made at regular intervals, will ensure years of trouble-free operation, giving special attention to the following:

- Keep unit clean
- Provide the motor with correctly sized overload protection. Keep moisture, refuse, dust or other loose particles away from the pump and ventilating openings of the motor.
- Avoid operating the unit in overheated surroundings (Above 100°F/40°C).

WARNING:



Whenever any service work is to be performed on a pumping unit, disconnect the power source to the driver, **lock it off** and tag with the reason. Any possibility of the unit starting while being serviced must be eliminated.

If mechanical seal environmental accessories are installed, ensure water is flowing through the sight flow indicator and that filter cartridges are replaced as recommended. (See Armstrong files 43.85 and 43.86 for seal environmental instructions).

2.7 LUBRICATION

Pump

Lubrication is not required. There are no bearings in the pump that need external lubrication service.

Large Design Envelope 4300 units are installed with a shaft bushing located beneath the impeller that is lubricated from the pump discharge.

Motor

Follow the lubrication procedures recommended by the motor manufacturer. Many small and medium sized motors are permanently lubricated and need no added lubrication. Generally if there are grease fittings evident the motor needs periodic lubrication. None if not.

Check the lubrication instructions supplied with the motor for the particular frame size indicated on the motor nameplate.

Mechanical Seal

The mechanical seal is fitted with a flush line. The seal is flushed from discharge of the pump casing on Design Envelope 4300 pumps and from the suction on Design Envelope 4380 pumps.

The Design Envelope 4300 pump is flushed from the pump discharge because the mechanical seal chamber is isolated from the liquid in the pump by a throttle bushing. Because the seal chamber is isolated, seal environmental controls such as filters and separators, when installed in the Design Envelope 4300 flush line are very effective, as only the seal chamber needs cleansing, and will prolong seal life in HVAC systems.

Do not run the pump unless properly filled with water as the mechanical seals need a film of liquid between the faces for proper operation.

Mechanical seals may 'weep' slightly at start-up. Allow the pump to continue operating for several hours and the mechanical seal to 'seat' properly prior to calling for service personnel.

The following Armstrong files are available for mechanical seal replacement instructions:

- Series 4300: TC Motor Frame - File 43.88
- Series 4380: File 43.81

2.8 SYSTEM CLEANLINESS

Before starting the pump the system must be thoroughly cleaned, flushed and drained and replenished with clean liquid.

Welding slag and other foreign materials, 'Stop Leak' and cleaning compounds and improper or excessive water treatment are all detrimental to the pump internals and sealing arrangement.

Proper operation cannot be guaranteed if the above conditions are not adhered to.

NOTE:

Particular care must be taken to check the following before the pump is put into operation:

- A** Pump primed?
- B** Rotation OK?
- C** Lubrication OK?
- D** Pipe work properly supported?
- E** Voltage supply OK?
- F** Overload protection OK?
- G** Is the system clean?
- H** Is the area around the pump clean?

WARRANTY

Does not cover any damages to the equipment resulting from failure to observe the above precautions. Refer to Armstrong General Terms and Warranty sheet. Contact your local Armstrong representative for full information.

FIG. 2.1 Hanger supported pipe mounted

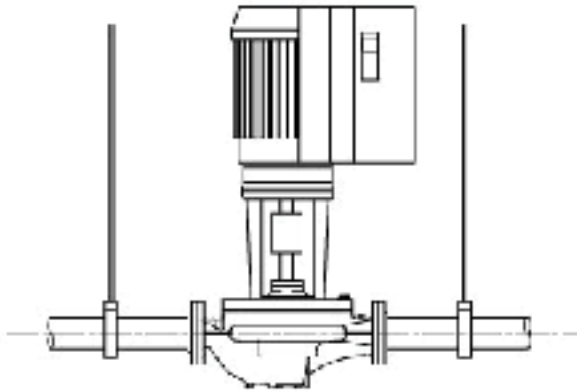

FIG. 2.3 Discharge elbow for minimum footprint

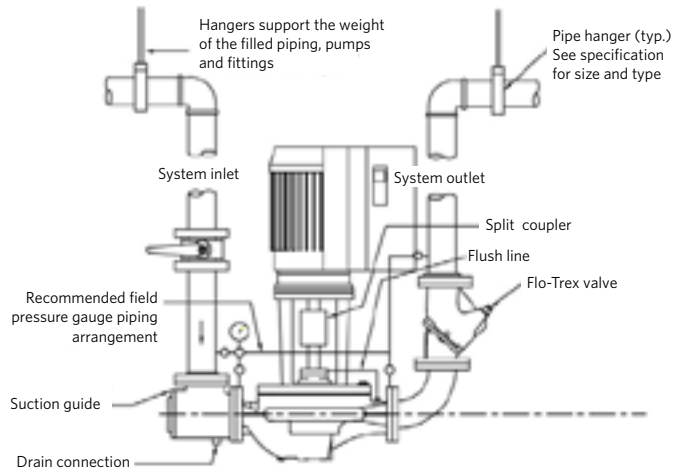

FIG. 2.2 Pipe mounted supported at ceiling

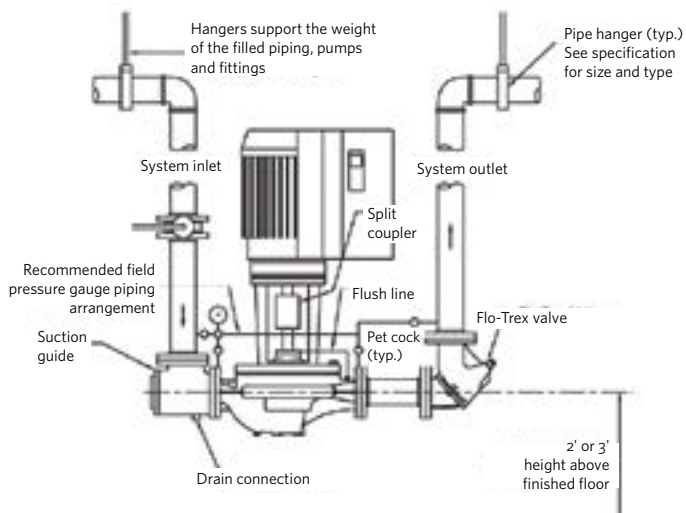

FIG. 2.4 With additional pipe supports

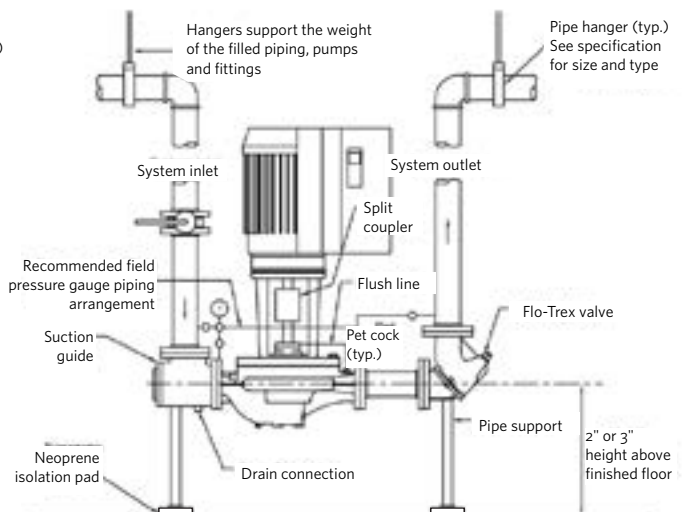

FIG. 2.5 Floor saddle support

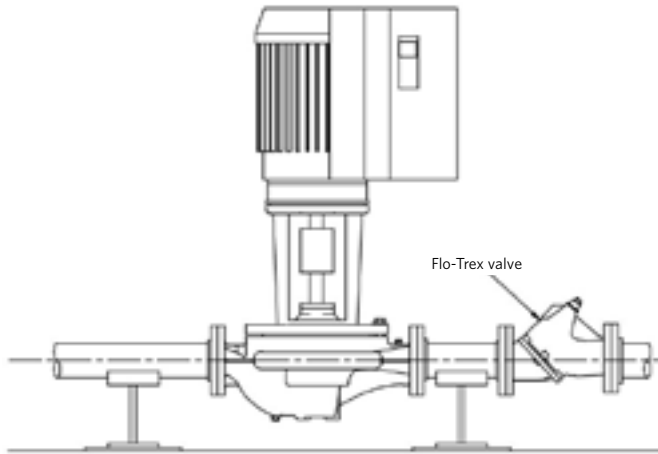

FIG. 2.7 With stanchion plates

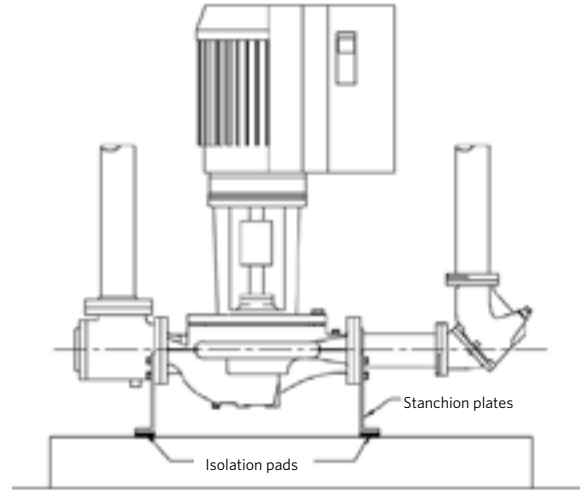

FIG. 2.6 Additional floor support

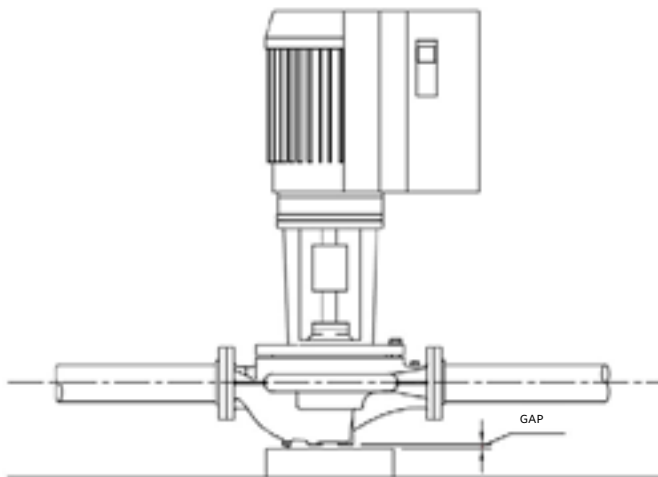

FIG. 2.8 Seismic region installation

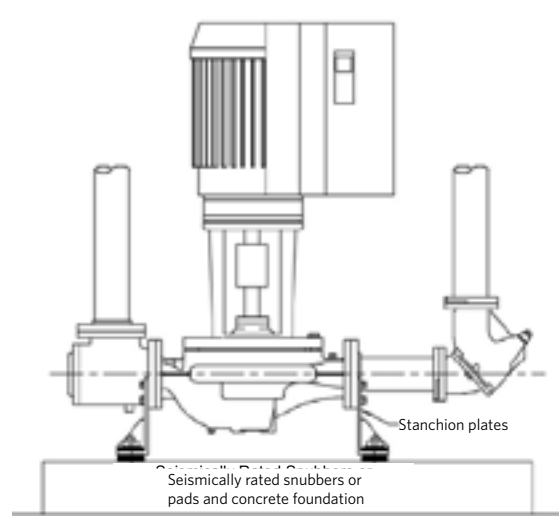

FIG. 2.9 Mounting in grooved pipe systems

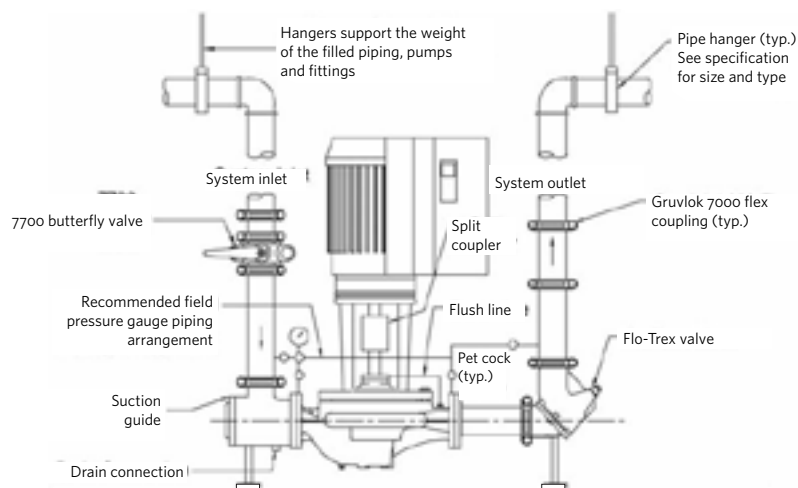

FIG. 2.10 Motor lifting hook supported

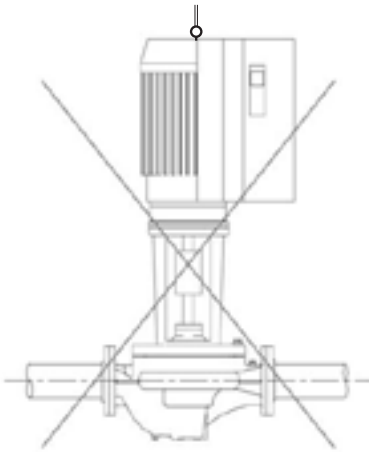

FIG. 2.13 Clearance radius for d size chassis

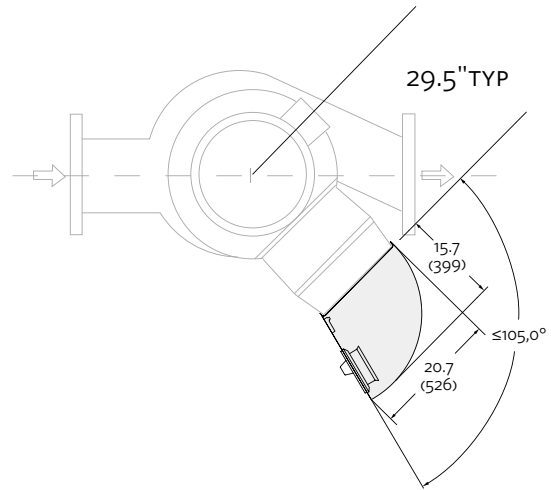

FIG. 2.11 Mounted on rigid base without
flexible connectors

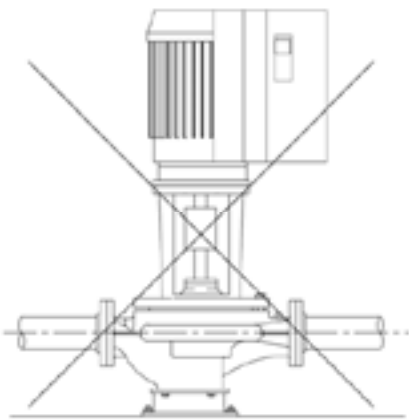

FIG. 2.14 Tapped collection well on series 4300

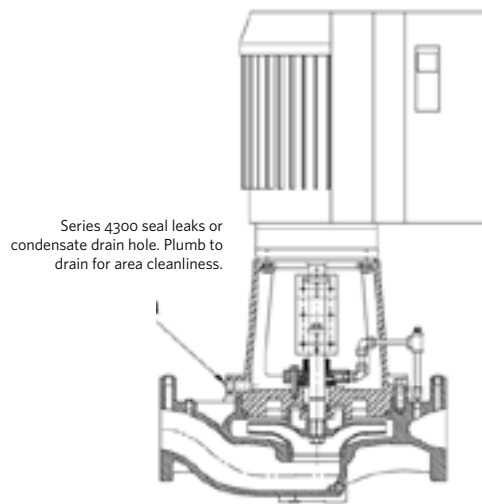
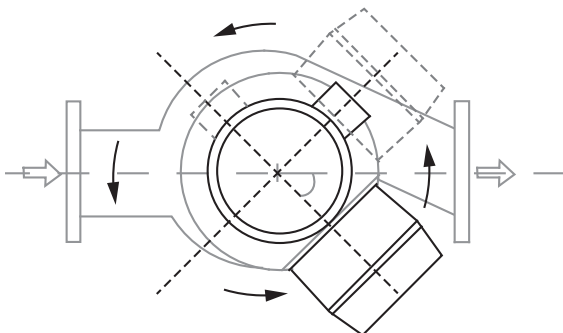

FIG. 2.12 Motor and integrated controls assembly can be
rotated in 90° increments to meet installation spacing
requirements



3.0 CE CONFORMITIES

For Declaration of Conformity certificates please contact Armstrong.

The Design Envelope product conforms to the requirements in the following directive(s), standard(s) or other normative document(s):

LOW VOLTAGE DIRECTIVE 2006/95/EC

EMC DIRECTIVE 2004/108/EC

MACHINERY DIRECTIVE 2006/42/EC

ECODESIGN DIRECTIVE 2009/125/EC

4.0 MECHANICAL INSTALLATION

Install the Design Envelope unit with adequate access for routine maintenance. Adequate space, particularly at the fan inlet (50 mm), is necessary to facilitate airflow. Where several Design Envelope units are installed in close proximity, care must be taken to ensure that there is no re-circulation of exhausted warm air.

With reference to **FIG. 3**, the pump should not be installed with the inverter in the underside position.



This guidance pertains to all pump types and overrides any instruction in the particular pump Installation, Operation and Maintenance Instruction.

FIG. 3 Allowable Installation Orientation - On-board Inverter Position

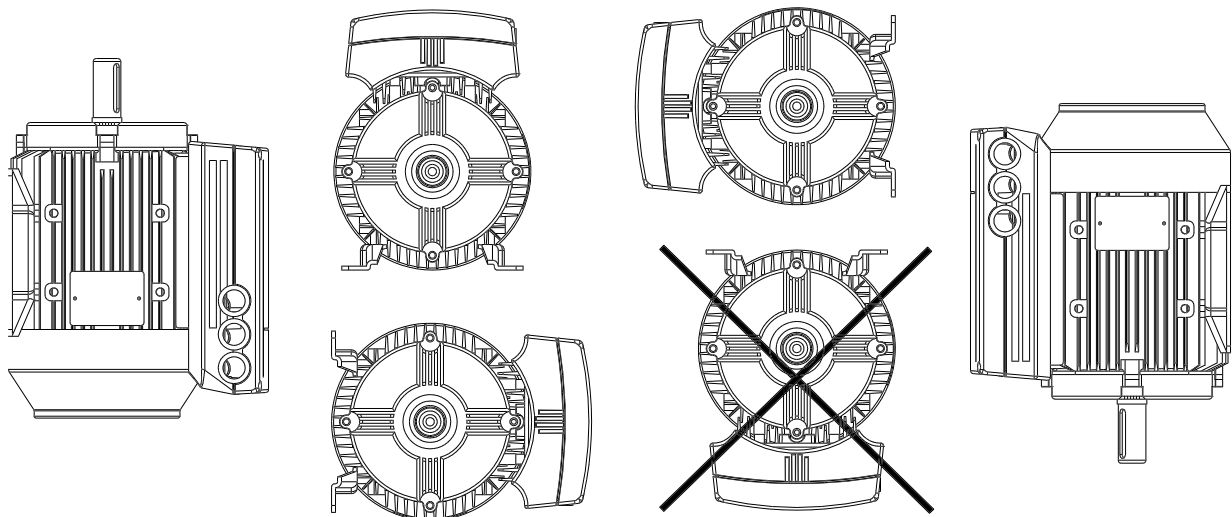

INTEGRATED CONTROLS

Power Rating 0.55 kW - 7.5 kW

4.1 ENCLOSURE RATING



The standard enclosure rating for Design Envelope pumps is IP55. If the pump is to be installed in a wet or dusty environment then a higher enclosure rating may be required (IP56 or IP66 option).

4.2 AMBIENT TEMPERATURE



To avoid the inverter unit getting overheated, the ambient temperature is not to exceed 40°C and the 24 hour average temperature is not to exceed 35°C. If the ambient temperature is in the range of 40°C - 55°C, a reduction of the service life of the inverter part is to be expected.

5.0 ELECTRICAL INSTALLATION



All electrical connections should be carried out by a qualified and authorised electrician in accordance with local site regulations and the latest issue of the IEE regulations.

SAFETY, RISK OF DEATH



Before removing the inverter cover, the system must be disconnected from the mains supply. After switching off wait for at least five minutes for the capacitors to discharge before opening the cover.

CAUTION



High voltage testing (Megging) of the motor / inverter may cause damage to the electronic components and therefore should not be carried out.

5.1 EARTH LEAKAGE CURRENT



Earth leakage current is primarily caused by the capacitance between motor phases and the motor frame. The RFI filter contributes additional leakage current, as the filter circuit is connected to earth through capacitors.

The size of the leakage current to the ground depends of the following factors, in order of priority:

- 1 Switching frequency
- 2 Motor grounded on site or not

The leakage current is of importance to safety during handling / operation of the Design Envelope pump if (by mistake) the on-board inverter has not been earthed.

ATTENTION:

Since the leakage current is >3.5 mA (approx 4 -20 mA), reinforced earthing must be established which is required by local wiring standards is to be complied with. Never use ELCB relays that are not suitable for DC fault currents (type A).

If ELCB relays are used, they must be:

- Suitable for protecting equipment with a direct current content (DC) in the fault current (three-phase bridge rectifier)
- Suitable for power-up with short charging current to earth
- Suitable for a high leakage current

5.2 EARTH LEAKAGE CURRENT

The number of starts / stops via the mains voltage must not exceed one time per two mins.

If a higher number of starts / stops is required then the start/ stop digital input must be used (mains voltage directly connected). This is the preferred method of starting and stopping Design Envelope Pumps.



The three phase mains must be isolated before performing maintenance of the pump.

5.3 ADDITIONAL MOTOR PROTECTION

With the exception of supply fuses / MCB's to protect the installation, no additional overload or over-temperature protection is required. Motor / inverter protection includes:

- Mains phase loss
- Over voltage
- Under voltage
- Over current
- Short circuit
- Over temperature

5.4 SUPPLY VOLTAGE

The supply voltage details can be found on the motor nameplate. Please ensure that the motor is suitable for the electrical supply on which it is to be used. The mains supply for Design Envelope pumps is as follows:

$3 \times 380/400/415/440/460/480V \pm 10\%$ Supply
frequency - 50/60HZ

5.5 TOOLS FOR INSTALLATION

One cross point screwdriver, one Large screwdriver,
one Small screwdriver

5.6 CABLE ENTRY SIZES

0.55kW - 4.0kW: $3 \times M20 \times 1.5$

5.5kW - 7.5kW: $1 \times M25 \times 1.5, 2 \times M20 \times 1.5$

One cable entry is factory fitted with a plug kit for external keypad connection.

5.7 MAX. CABLE CROSS SECTION

Mains cable supply: 4.0mm^2

Control cable: 1.5mm^2

Serial communication cable: 1.5mm^2

FIG. 4 Inverter Terminal Arrangement

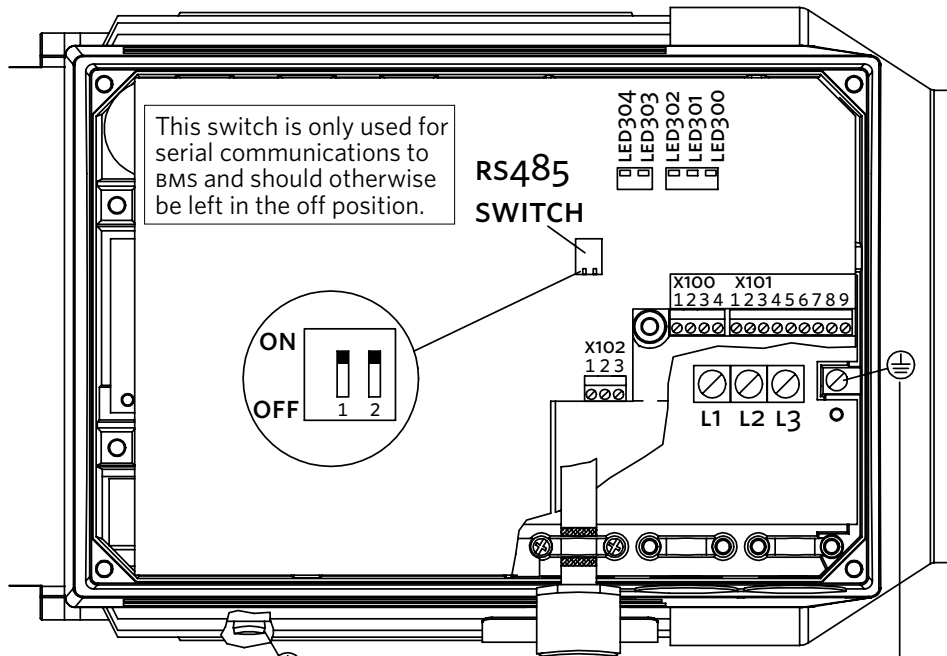

5.8 MAINS SUPPLY CONNECTION

- I Remove the inverter box cover, which is held by four screws (6 on 5.5 and 7.5 kW units), to obtain access to the terminals.
- II Remove the detachable terminal plugs from the terminal blocks x100 and x101 to obtain access to the mains terminals.
- III Lift only the corner of the black plastic cover by the cable entries to expose the mains terminals L1, L2 and L3.



DO NOT lift or remove the entire plastic cover. This is part of the inverters protective arrangements.



Mains Terminals L1, L2 and L3

Make sure that your mains supply corresponds to the voltage required by the Design Envelope unit (see motor nameplate), TT and TN mains.

- IV Remove the gland plug furthest from the drive end of the motor (to the right in fig. 2) and feed the mains cable through the hole.
- V Connect the three mains phases to terminals L1, L2 and L3 and the earth to the separate terminal provided.



DO NOT over-tighten the mains terminals as this will damage the unit!

0.55 - 4.0 kW torque - 0.5 to 0.6 Nm
5.50 - 7.5 kW torque - 1.2 to 1.5 Nm
Earth terminal - 3.4Nm

- VI Remove the middle gland plug and feed the control cable through the hole (see the section on control connections for wiring details).
- VII The third entry is fitted with a plug kit to facilitate keypad connection. Do not remove the kit or wiring unless as serial communications link (to BMS) is required.



You cannot change the rotational direction of the pump by shifting around the input mains phases. The direction of rotation is factory set.

5.9 CONTROL CONNECTIONS

Terminal blocks x100, x101 and x102 are used for control connections. Individual terminal allocation is as follows:

x100 Terminals

The x100 terminals are used for data communications, either as part of a serial communications network or for connection to the cable gland mounted plug kit for key pad connection (Default).

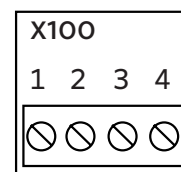

TERMINAL	WIRE COLOR
1	Yellow
2	Green
3	Red
4	Blue

x101 Terminals - Control Terminals

The x101 terminals are used for analogue and digital signals that will determine the operation of the pump(see the section on Control Modes).

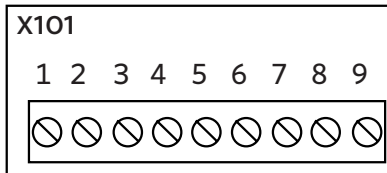

- **Terminal 1** - 4-20 mA input for a remote feedback device (when Sensorless control is not used).
- **Terminal 2** - 0-10V input for a reference signal (when Sensorless control is not used).
- **Terminal 3** - Digital input for a low water device (pump only runs if input is 'logic 1') - factory linked with zero ohm resistor to terminal 6.
- **Terminal 4** - Digital input for pump start (pump enabled when 'logic 1').
- **Terminal 5** - Digital input for pump mode (if left at 'logic 0' then pump will be in sensorless mode).
- **Terminal 6** - 24V DC supply for terminals 3 to 5 (max 150 mA).
- **Terminal 7** - 10V DC supply for terminal 2 when used with a potentiometer (max 15 mA).
- **Terminal 8** - 0V for terminals 1 to 7 and 9.
- **Terminal 9** - Digital output for 'pump fault' connection to BMS (voltage level will be 24V DC when pump has a fault).

ATTENTION:

Terminal 9 is not a volt-free contact. Connection of an external voltage will destroy the unit.

x102 Terminals - Pump Running

The x102 terminals provide a relay changeover contact for identification of pump running.

Terminals 1 - 2 will be made when the pump is running. Voltage level at contact/load (AC) 250V AC, 5A Voltage level at contact/load (DC) 30V DC, 5A; 40V DC, 2A; 100V DC, 0.5A

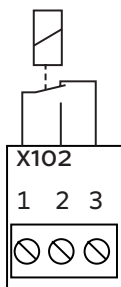

5.9.1 CONNECTION EXAMPLES

There are many ways that an Design Envelope pump can be configured. The following is some examples of the most common control configurations.

I Sensorless Pressure Control - Connection Details

Design Envelope pumps are factory configured to be connected as shown below. For a description of sensorless pressure control please refer to the programming section.

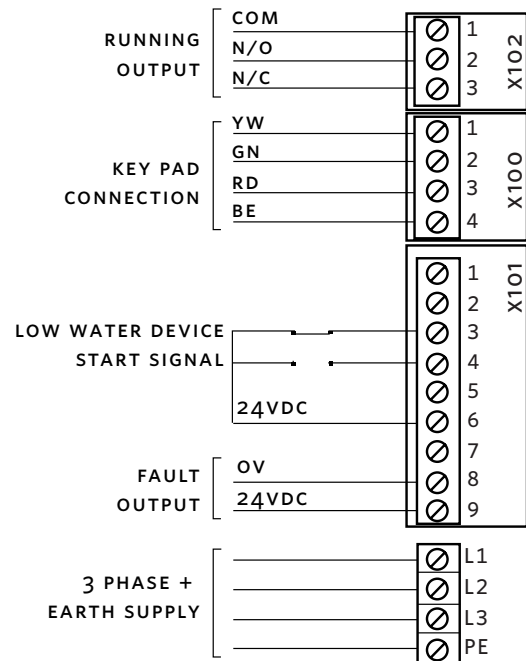

II Full speed override

It may be required to run the pump at full speed without automatic speed control (e.g. during system commissioning). This can be achieved without programming changes by making the control connections shown below.

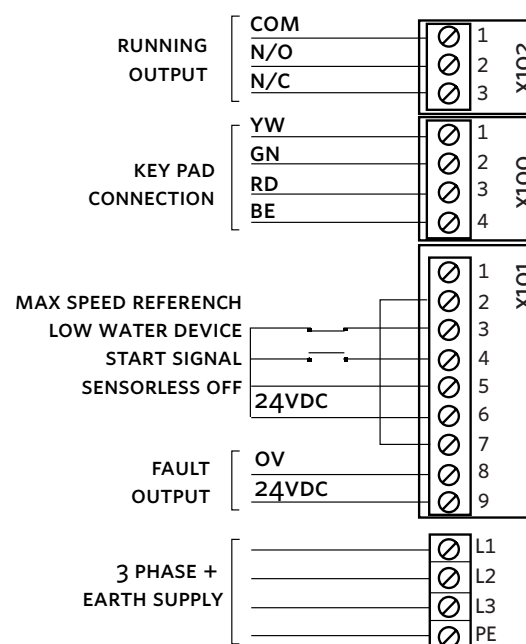

III Constant curve mode - BMS speed control

Where the Building Management System is to be used for speed control it is necessary to disable sensorless control and provide the unit with a 0 - 10V DC speed reference signal.

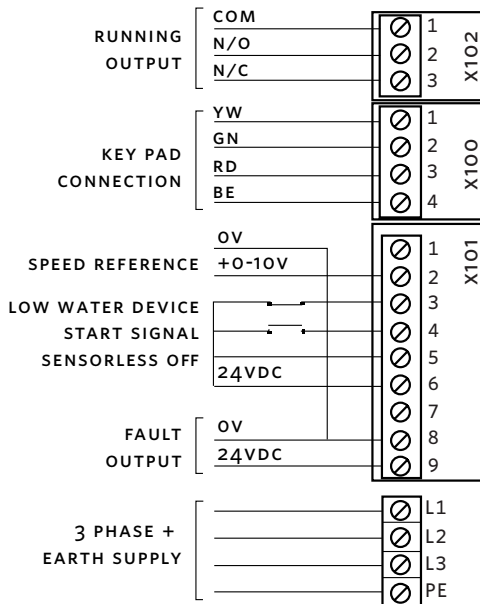

As shown above, in Constant curve mode the pump will speed up and slow down according to the voltage level of the reference signal. On a unit configured for 50 HZ pump speed the reference signal is scaled (by default) so that 0V on X100 terminal 2 will equate to 0 HZ and 10V will equate to 50 HZ.

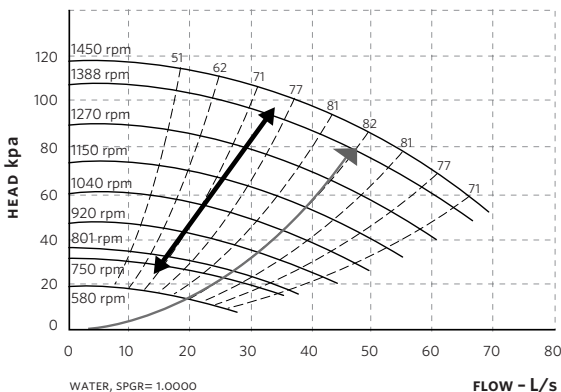

IV Constant curve mode - Potentiometer speed control

If a potentiometer is to be installed for manual control of pump speed then the control connections will be as follows:

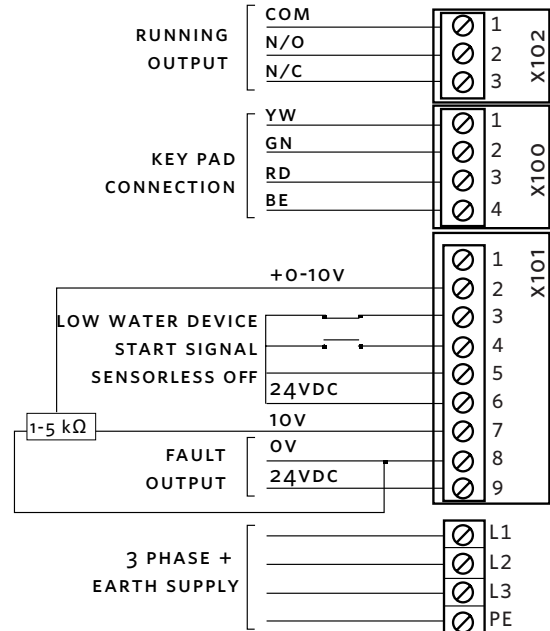

The recommended minimum speed for Design Envelope pumps is 580 rpm. Running for long periods below this speed can damage the mechanical seal.

6.0 PROGRAMMING, MONITORING AND DIAGNOSTICS

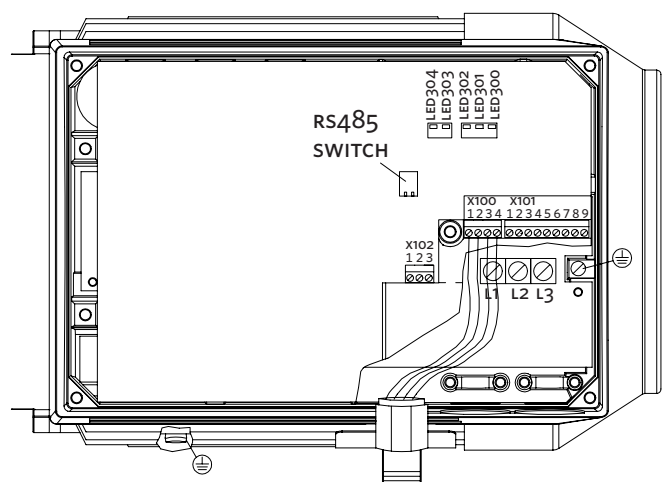

A key pad tool (LCP) is available for Design Envelope Pumps as an option. The LCP gives the user full programming and monitoring capabilities and it is recommended that at least one LCP and cable kit are purchased for each installation site.

The LCP is connected via a cable to the 'plug kit' mounted in one of the inverter cable entries as shown above.

6.1 LCP FUNCTIONS AND OPERATION

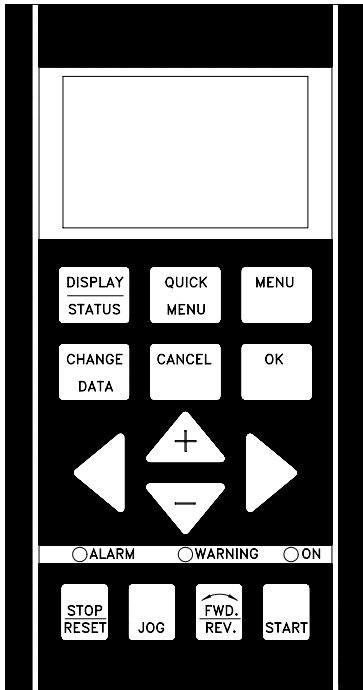

The functions of the control panel can be divided into three groups:

- Display
- Keys for changing program parameters
- Keys for local operation

All data is indicated by means of a 4 -line alphanumeric display, which in normal operation is able show 4 measurements and 3 operating conditions continuously. During programming, all the information required for quick, effective parameter Setup of the Design Envelope Pump will be displayed. As a supplement to the display, there are three LEDs for voltage, warning and alarm. All program parameters of the Design Envelope Pump can be changed immediately from the control panel, unless this function has been blocked via parameter o18.

6.1.1 DISPLAY

The LCD-display has rear lighting and a total of 4 alpha - numeric lines together with a box that shows the direction of rotation (arrow) and the chosen Setup as well as the Setup in which programming is taking place if that is the case.

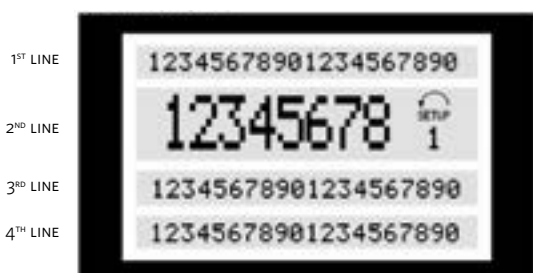

1st line shows up to 3 measurements continuously in normal operating status or a text which explains the 2nd line.

2nd line shows a measurement with related unit continuously, regardless of status (except in the case of alarm/warning).

3rd line is normally blank and is used in the menu mode to show the selected parameter number or parameter group number and name.

4th line is used in operating status for showing a status text or in data change mode for showing the value of the selected parameter.

An arrow indicates the direction of rotation of the pump (factory set). Furthermore, the Setup which has been selected as the Active Setup in parameter 004 is shown. **12** When programming another Setup than the Active Setup, the number of the Setup which is being programmed will appear to the right. This second Setup number will flash.

6.1.2 LED'S

At the bottom of the control panel is a red alarm LED and a



yellow warning LED, as well as a green voltage LED.

If certain threshold values are exceeded, the alarm and/or warning lamp lights up together with a status and alarm text on the control panel. The voltage LED is activated when the Design Envelope Pump receives voltage; at the same time the rear lighting of the display will be on.

6.1.3 CONTROL KEYS

The control keys are divided into functions. This means that the keys between display and indicator LEDs are used for parameter Setup, including choice of display indication during normal operation.

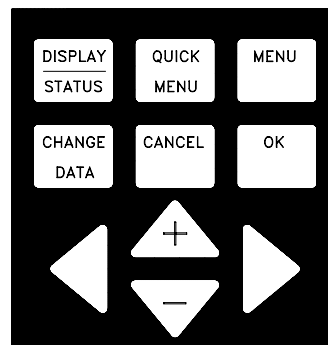

Keys for local control are found under the indicator LEDs.

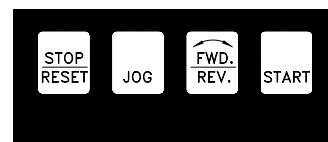

Control key functions

- DISPLAY / STATUS** **[DISPLAY / STATUS]** is used for selecting the mode of display or for changing back to Display mode from either the Quick menu mode or the Menu mode.
- QUICK MENU** **[QUICK MENU]** is used for programming the parameters that belong under the Quick menu mode. It is possible to switch directly between Quick menu mode and Menu mode.
- MENU** **[MENU]** is used for programming all parameters. It is possible to switch directly between Menu mode and Quick menu mode.
- CHANGE DATA** **[CHANGE DATA]** is used for changing the parameter selected either in the Menu mode or the Quick menu mode.
- CANCEL** **[CANCEL]** is used if a change of the selected parameter is not to be carried out.
- OK** **[OK]** is used for confirming a change of the parameter selected.
- +/-** **[+/-]** is used for selecting parameter and for changing the chosen parameter or for changing the read out in line 2.
- <>** **[<>]** is used for selecting group and to move the cursor when changing numerical parameters.
- STOP / RESET** **[STOP / RESET]** is used for stopping or for resetting the pump after a drop-out (trip). Can be selected via parameter 014 to be active or inactive. If stop is activated, line 2 will flash, and **[START]** must be activated.

ATTENTION:

Pressing **[STOP/RESET]** will prevent the pump from running also with disconnected LCP. Restarting is only possible via the LCP **[START]** key.

- JOG** **[JOG]** overrides the output frequency to a preset frequency while the key is kept down. Can be selected via parameter 015 to be active or inactive.
- FWD. / REV.** **[FWD. / REV.]** changes the direction of rotation of the motor, which is indicated by means of the arrow on the display although only in Local. This key is inactive by default.
- START** **[START]** is used for starting the pump after stop via the **[STOP]** key. Is always active, but cannot override a stop command given via the terminal strip.

6.1.4 DISPLAY MODE

In normal operation, up to 4 different operating variables can be indicated continuously: 1,1 and 1,2 and 1,3 and 2, and in line 4 the present operating status or alarms and warnings that have arisen.



There are three options in connection with the choice of read-out state in the Display mode - I, II and III. The choice of read-out state determines the number of operating variables read out.

READ-OUT STATE:	I	II	III
Line 1	Description for operating variable in line 2	Data value for 3 operating variables in line 1	Description for 3 operating variables in line 1

The table below gives the units linked to the variables in the first and second line of the display (see parameter 009).

OPERATING VARIABLE	UNIT
Reference	[%]
Reference	[unit]*
Feedback	[unit]*
Frequency	[Hz]
Frequency x scaling	[-]
Motor current	[A]
Torque	[%]
Power	[kW]
Power	[HP]
Motor voltage	[V]
dc-link voltage	[V]
fc thermal	[%]
Hours run	[Hours]
Input status, dig. Input	[Binary code]
External reference	[%]
Status word	[Hex]
Heat sink temp.	[°C]
Alarm word	[Hex]
Control word	[Hex]
Warning word 1	[Hex]
Warning word 2	[Hex]
Analog input 1	[mA]
Analog input 2	[V]
Sensorless power	[W]
Sensorless flow	[l/s]
Sensorless head	[kPa]

* Select in parameter 416. The unit is shown in readout state 1 line 1 otherwise 'U' is shown.

20

Operating variables 1,1 and 1,2 and 1,3 in the first line, and operating variable 2 in the second line are selected via parameter 009, 010, 011 and 012.

Read-out state I:

This read-out state is standard after starting up or after initialisation.

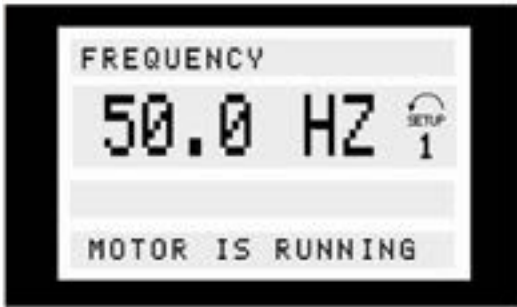

Line 2 gives the data value of an operating variable with related unit, and line 1 provides a text which explains line 2, cf. table. In the example, Frequency has been selected as variable via parameter 009.

During normal operation another variable can immediately be read out by using the [+/-] keys.

Read-out state II:

Switching between read -out states I and II is effected by pressing the [DISPLAY / STATUS] key.

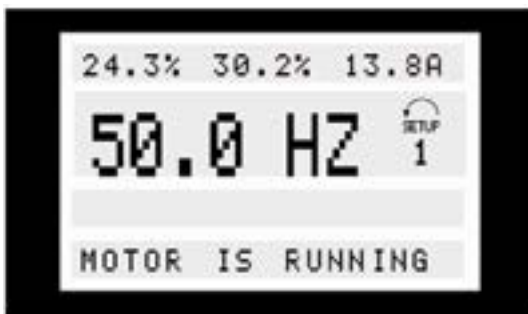

In this state, data values for four operating values are shown at the same time, giving the related unit, cf. table. In the example, Reference, Torque, Current and Frequency are selected as variables in the first and second line.

Read-out state III:

This read-out state can be held as long as the [DISPLAY / STATUS] key is pressed. When the key is released, the system switches back to Read-out state II, unless the key is pressed for less than approx. 1 sec.



This is where parameter names and units for operating variables in the first line are given - operating variable 2 remains unchanged .

6.1.5 QUICK MENU

Quick menu gives access to a limited number of parameters but does not include parameters that may need to be changed when utilising sensorless control. It is therefore recommended that parameter changes are made in the standard menu.

6.1.6 MENU MODE

The Menu mode makes it possible to select and change all parameters at the user's option.

However, some parameters will be missing, depending on the choice of configuration (parameter 100), e.g. open loop hides all the PID parameters.

In addition to having a name, each parameter is linked up with a number which is the same regardless of the programming mode. In the Menu mode, the parameters are divided into groups, with the first digit of the parameter number (from the left) indicating the group number of the parameter in question. Regardless of the mode of programming, a change of a parameter will take effect and be visible both in the Menu mode and in the Quick menu mode.

The Menu mode is started by pressing the [MENU] key, which produces the following readout on the display:



Line 3 on the display shows the parameter group number and name.

Parameter Groups

This read-out state is standard after starting up or after initialisation.

In the Menu mode the parameters are divided into groups. Selection of parameter group is effected by means of the [↔] keys.

The following parameter groups are accessible:

GROUP NO.	PARAMETER GROUP:
0	Operation & display
1	Load & motor
2	References & limits
3	Inputs & outputs
4	Special functions
5	Serial communication
6	Technical functions
7	Sensorless control

When the desired parameter group has been selected, each parameter can be chosen by means of the [+/-] keys:



The 3rd line of the display shows the parameter number and name, while the status/value of the selected parameter is shown in line 4.

Changing Data

Regardless of whether a parameter has been selected under the Quickmenu or the Menu mode, the procedure for changing data is the same. Pressing the [CHANGE DATA] key gives access to changing the selected parameter, following which the underlining in line 4 will flash on the display. The procedure for changing data depends on whether the selected parameter represents a numerical data value or a text value.

Changing a Text Value

If the selected parameter is a text value, the text value is changed by means of the [+/-] keys.



The bottom display line shows the text value that will be entered (saved) when acknowledgement is given [OK].

Infinitely variable change of numeric data value

If the chosen parameter represents a numeric data value, a digit is first selected by means of the [↔] keys.



Then the chosen digit is changed infinitely variably by means of the [+/-] keys:



The chosen digit is indicated by the digit flashing. The bottom display line shows the data value that will be entered (saved) when signing off with [OK].

MENU STRUCTURE

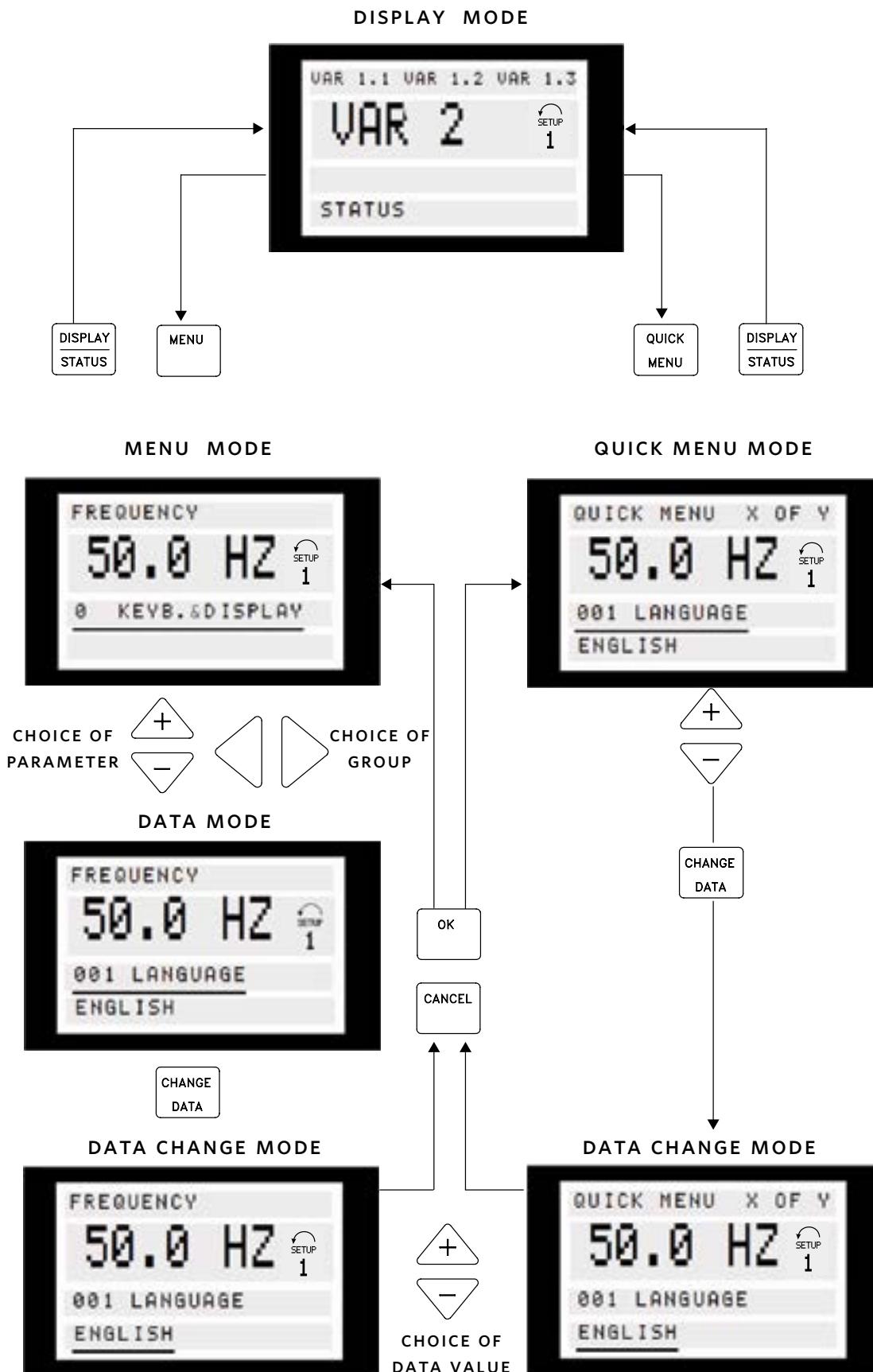

7.0 SENSORLESS OPERATION

Sensorless control is an innovative concept in glanded circulating pumps. Pump performance and characteristic curves for ten different speeds are embedded in the memory of the speed controller during manufacture. This data includes power, pressure and flow across the flow range of the pump. During operation, the power and speed of the pump are monitored, enabling the controller to establish the hydraulic performance and position in the pumps head-flow characteristic.

These measurements enable the pump to continuously identify the head and flow at any point in time, giving accurate pressure control without the need for external feedback signals. Patented software technology within the controller ensures trouble-free operation in all conditions. Incorporating the pumps hydraulic data into the controller and removing sensors results in true integration of all components and removes the risk of sensor failure.

7.1 DEFAULT OPERATING MODE - QUADRATIC PRESSURE CONTROL

The default control mode for Design Envelope pumps 'Quadratic Pressure Control' where the controller is set to control the speed according to a 'control curve' between max and min flow

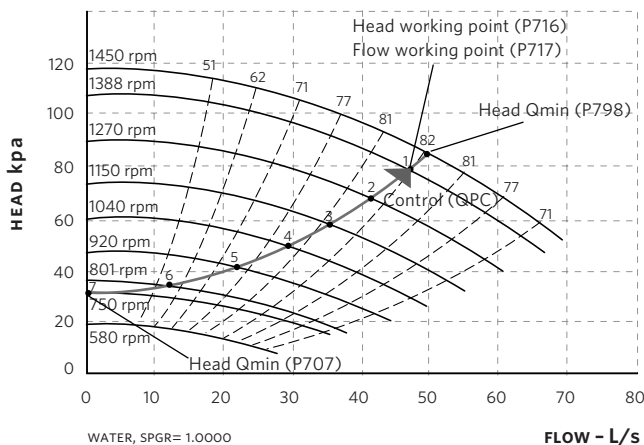

(see above diagram). It is widely recognised that fitting a differential pressure sensor at the most remote load, across the supply piping and return piping encompassing the valve & coil set, is the best installation scheme for energy efficiency.

Design Envelope pumps can replicate this control without the need for the remote sensor. As the flow required by the system is reduced, the pump automatically reduces the head developed according to the pre-set control curve. It is often found that using a remote differential pressure sensor to sense the pressure across a remote load could theoretically result in loads close to the pump being underpumped.

The situation would be where the load at a loop extremity is satisfied and the control valve closes while a load close to the pump needs full flow.

The probability of this occurring is remote but it is possible. One answer to this is to move the sensor closer to the pump (two-thirds out in the system is a popular recommendation) although physically re-positioning the sensor at commissioning stage can be a costly exercise. With Sensorless pump control it is possible to replicate the moving of a sensor by adjusting the head setting 'Head Q_{min} '.

7.1.1 DESCRIPTION OF SETTINGS

The design duty head and flow of the pump (provided at time of order) is defined by the controller as 'head working point' and 'flow working point'. The minimum head (Head Q_{min}) is defined as a percentage of the head working point. The maximum controllable head (Head Q_{max}) is the head developed when the pump reaches full speed and is calculated by the other two head settings.

7.1.2 SETTING PARAMETERS FOR QUADRATIC PRESSURE CONTROL

- **Parameter 716** - Enter the head (kPa) at design flow.
- **Parameter 717** - Enter the design flow (l/s).
- **Parameter 707** - Enter the minimum head requirement (as a percentage of P716).
- **Parameter 705** - Quadratic Head should be set to 'ON'.
- **Parameter 798** - This is a calculated value from the settings above and should not be changed.

7.2 CONSTANT PRESSURE CONTROL

Design Envelope pumps can be configured to maintain a constant pressure in a system as the demand varies. This effectively simulates the mounting of a differential pressure sensor at, or near, the pump.

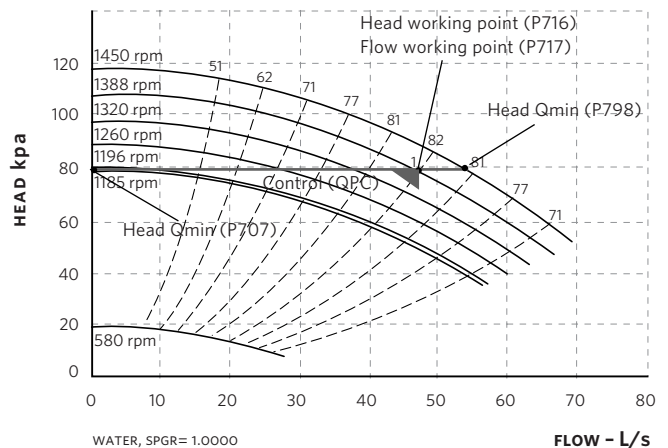

7.2.1 SETTING PARAMETERS FOR CONSTANT PRESSURE CONTROL

- **Parameter 716** - Enter the head (kPa) at design flow.
- **Parameter 717** - Enter the design flow (l/s).
- **Parameter 707** - Enter the minimum head requirement (as a percentage of P716), which will be 100% for constant pressure.
- **Parameter 705** - Quadratic Head should be set to 'OFF'.
- **Parameter 798** - This is a calculated value from the settings above and should not be changed.

7.3 PROPORTIONAL PRESSURE CONTROL

Where a linear reduction in head is required with reducing flow then the quadratic curve should be turned off.

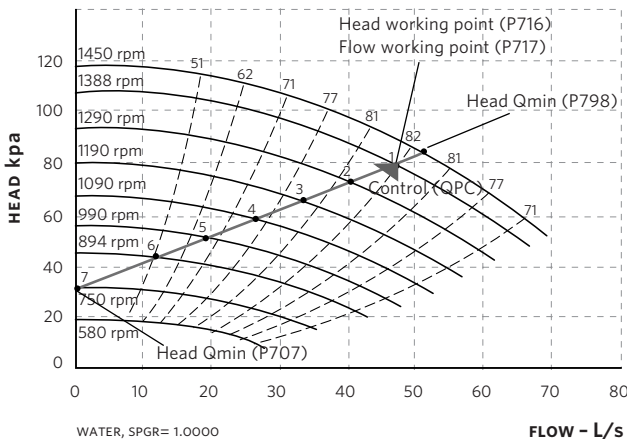

7.3.1 SETTING PARAMETERS FOR PROPORTIONAL PRESSURE CONTROL

- **Parameter 716** - Enter the head (kPa) at design flow.
- **Parameter 717** - Enter the design flow (l/s).
- **Parameter 707** - Enter the minimum head requirement (as a percentage of P716).
- **Parameter 705** - Quadratic Head should be set to 'OFF'.
- **Parameter 798** - This is a calculated value from the settings above and should not be changed.

8.0 CONTROL USING EXTERNAL FEEDBACK (CLOSED LOOP CONTROL).

Design Envelope pumps can be configured (using the keypad) to accept a feedback signal from a remote sensor (e.g. temperature transmitter for constant temperature). The connection of an external device will depend on the device itself although typical devices are 4-20mA, 2 wire where the supply will be provided by 24V DC on terminal 6 of x101 and the output signal connected to terminal 1 of x101.

The parameter list following this section gives typical settings for closed loop control.

8.1 PARAMETER GROUPS AND DESCRIPTIONS.

GROUP 0 - OPERATION AND DISPLAY.

Language/Local Control - Parameters 001,002, 003
Not normally changed.

Active Set-up - Parameter 004

It is possible to program two separate sets of data for controlling the inverter.

Program Set-up - Parameter 005

The active set-up can be either set-up 1, set-up 2 or can be remotely switched between the two.

Copying of Set-ups - Parameter 006

A copy is made from the set-up selected in parameter 005 and copied to the set-up selected in parameter 006.

Copying of Set-ups Between Inverters - Parameter 007

- Connect key pad to the inverter from which the desired set-up is to be copied.
- Select 1 in parameter 007 to upload all parameters into the key pad.
- Connect key pad to the inverter to which the desired set-up is to be copied.
- Select 3 in parameter 007 to download all parameters into the inverter.
- By selecting 3 in parameter 007, copying from one size of inverter to a different size will not affect the power settings.

Display Scaling - Parameter 008

Multiplication factor of frequency (normally set at 1).

Display Configuration - Parameters 009-012

Allows choice of data to displayed in lines 1 and 2 of the key pad.

Local Operations - Parameters 013 -019

Not normally changed.

GROUP 1 - LOAD AND MOTOR.

Configuration - Parameter 100

Sets the configuration under which the inverter is controlled.

ATTENTION:

Set to **Process Closed Loop** for control via the 4 -20mA transducer feedback input set to **Speed Open Loop** for Potentiometer, BMS or Sensorless control.

Motor Settings – Parameters 101-141

ATTENTION:

Are motor related parameters and are not normally changed.

GROUP 2 – REFERENCE AND LIMITS.

Rotation Direction – Parameter 200

ATTENTION:

Sets rotation direction, normally set at 132 HZ counter clockwise.

Minimum Output Frequency – Parameter 201

Minimum output frequency is normally set at 0 to 21 HZ dependant on the mode of operation.

Maximum Output Frequency – Parameter 202

Maximum output frequency is normally set at 50 HZ. This figure should not be exceeded as the inverter could be overloaded.

Reference Feedback – Parameter 203

Set to Min-Max and not normally changed.

Minimum Reference – Parameter 204

If operating in closed loop mode, set to minimum scale of the feedback sensor, normally set to 0.0.

NOTE:

Units of measurement are selected in parameter 416.

If operating in open loop mode, the units can only be displayed as HZ, normally set to minimum speed 0.0 HZ.

Ramp Up/Down Times – Parameters 207, 208, 211, 212

Ramp up times normally set to 10 seconds.

ATTENTION:

Ramp down times normally set to 3 seconds. Longer times should be used with higher kW motors.

Jog Frequency – Parameter 213

Normally set to 50 HZ when the jog function is activated it will override the normal reference input and run the pump at the preset jog reference.

Reference Function – Parameter 214

Set to Sum. Not normally changed.

Preset Reference 1 – Parameter 215

(Set Point) if operating in closed loop mode, this parameter should be set to the required set point as a percentage of the maximum range of the feedback sensor. i.e. Sensor range 0 -4.0 Bar, set point required 2.0 Bar, parameter would be set to 50%. If operating in open loop mode or sensorless mode this parameter should be set to 0%.

Preset Reference 2 – Parameter 216

Set to 0% and not normally used.

Catch Up/Slow Down – Parameter 219

Set to 0% and not normally used.

Frequency Bypass Bandwidth – Parameter 229

If a skip frequency is entered at parameter 230 or 231 a % bandwidth either side of these frequencies can be defined in this parameter.

Frequency Bypass – Parameters 230-231

If resonance problems occur at particular frequencies, It is possible to program two frequencies to be avoided.

GROUP 3 – INPUTS AND OUTPUTS.

Inputs and Outputs – Parameters 317-340

These parameters are not normally changed.

GROUP 4 – SPECIAL FUNCTIONS.

Special Functions – Parameters 400-446

These parameters are not normally changed.

GROUP 5 – SERIAL COMMUNICATIONS.

Bus Address – Parameter 500

This parameter allows specification of the address for each inverter. Used in conjunction with PLC/PC connection. Address 0 is used for the master unit, addresses 1-126 for slave units. A repeater unit will be required if the total number of slave units exceeds 30.

Baudrate – Parameter 501

Sets the speed of communication, set to a value that corresponds with the transmission speed of the PLC/PC.

Drive Control – Parameters 502-508

Allows control via terminal inputs and/or the Bus.

Bus Jog Frequency – Parameters 509-510

Activates the jog frequency via the Bus.

Protocol – Parameter 512

Selects the control word profile 0=Profidrive, 1=FC Drive.

Data Output – Parameters 513-635

Read only values of various functions.

For further information on serial communication, contact Armstrong.

GROUP 6 – TECHNICAL FUNCTIONS.

Operating Hours - Parameter 600

Readout of inverter operating time, updated hourly.

Run Hours - Parameter 601

Readout of inverter running time, updated hourly.

Power Ups - Parameter 603

Readout of number of power-ups.

Over Temperatures - Parameter 604

Readout of temperature faults.

Over Voltages - Parameter 605

Readout of over-voltage faults.

Fault Log - Parameter 615

Readout of last 10 trip codes, the lowest log number contains the latest fault. (See Page 5 for Fault Code list).

Fault Log Time - Parameter 616

Readout shows total number of operating hours before trip occurred. The lowest log number contains the latest data.

Fault Log Value - Parameter 617

Readout shows current or voltage when the trip occurred.

Reset Hours Run Counter - Parameter 619

To reset the hours run counter in parameter 601 to zero select 1.

Inverter Data - Parameters 620-635

Read only values of inverter identification numbers.

GROUP 7 – SENSORLESS FUNCTIONS.

Sensorless Control On/Off - Parameter 700

Set to 'ON' for Sensorless control. For all other modes of control set to 'OFF'.

Power Error - Parameter 701

Normally set to 20W, this allows a fast but rough response to the output HZ. Not normally changed.

Delta Frequency - Parameter 702

Normally set to 0.2 HZ, as parameter 701, this allows a fast but rough response to the output HZ. Not normally changed.

Integral Power - Parameter 703

Normally set to 20, this allows more precise adjustments to the output HZ. Not normally changed.

Integral Frequency - Parameter 704

Normally set to 20, as parameter 703, this allows more precise adjustments to the output HZ. Not normally changed.

Quadratic Head - Parameter 705

Normally set to 'ON'. In the 'OFF' position a linear curve between Min/Max head is produced. In the 'ON' position a quadratic curve between Min/Max head is produced.

Head Minimum - Parameter 707

Normally set to 40%. This will provide a 60% reduction in head at 'No Flow' conditions. Set to 100% if a constant head is required across the full flow range.

Power Consumption - Parameter 708

Normally set to 0 option correction factor that mainly affects the head reference at high flow values.

Temperature Rise Rated - Parameter 710

Normally set to 80°C. This specifies the estimated difference in rotor temperature from idle running conditions to maximum loaded conditions.

TAU Therm. - Parameter 711

Normally set to 300 Seconds. This specifies the estimated time it will take the rotor temperature to rise from idle temperature to 67% of the maximum temperature, at maximum loaded conditions.

Slip 0°C - Parameter 712

Normally set to 0%. This specifies the estimated change in motor slip at the idle temperature compared with the nominal slip of the motor at idle load.

Slip 100°C - Parameter 713

Normally set to 0%. This specifies the estimated change in motor slip at the temperature 100°C above the idle temperature, compared with the nominal slip of the motor at maximum load.

Head Working Point - Parameter 716

Design duty head value (kPa)

Flow Working Point - Parameter 717

Design duty flow value (l/s)

Head Maximum - Parameter 798

Shows the maximum controlled head (at max speed). This parameter is automatically calculated using parameter 716, 717 and 707.

Protocol - Parameter 561

Fieldbus Communication: FC Protocol, Modbus RTU

DESCRIPTION	PARAMETER	SENSORLESS	OPEN LOOP	CLOSED LOOP
Language	001	English	English	English
Local/remote control	002	Local	Remote	Remote
Local reference	003	0.000	0.000	0.000
Active setup	004	Multi setup	Setup 1	Setup 1
Programming setup	005	Active setup	Active setup	Active setup
Copying of setups	006	No copy	No copy	No copy
LCP copy	007	No copy	No copy	No copy
Display scaling of motor frequency	008	1.00	1.00	1.00
Display line 2	009	Frequency [Hz]	Frequency [Hz]	Frequency [Hz]
Display line 1.1	010	Sensorless head [kpa]	Reference [%]	Reference [Unit]
Display line 1.2	011	Sensorless power [W]	Motor current [Amps]	Feedback [Amps]
Display line 1.3	012	Sensorless flow [L/s]	Power [kW]	Power [kW]
Local control/configuration	013	LCP dig control/par 100	LCP dig control/Par 100	LCP dig control/par 100
Local stop	014	Enable	Enable	Enable
Local jog	015	Enable	Disable	Disable
Local reversing	016	Disable	Disable	Disable
Local reset of trip	017	Enable	Enable	Enable
Lock for data change	018	Not locked	Not locked	Not locked
Operating state at power up, Local control	019	Auto restart	Local = Stop	Local = Stop
Configuration	100	Speed open loop	Speed open loop	Process closed loop
Torque characteristics	101	Constant torque	Variable torque - med	Variable torque - med
Motor power	102	Unit dependant	Unit dependant	Unit dependant
Motor voltage	103	Unit dependant	Unit dependant	Unit dependant
Motor frequency	104	Unit dependant	Unit dependant	Unit dependant
Motor current	105	Unit dependant	Unit dependant	Unit dependant
Rated motor speed	106	Unit dependant	Unit dependant	Unit dependant
Resonance damp	117	Off	Off	Off
dc braking time	126	10.0 seconds	10.0 seconds	10.0 seconds
dc brake cut -in frequency	127	Off	Off	Off
Motor thermal protection	128	Disable	Disable	Disable
dc braking voltage	132	Off	Off	Off
Start voltage	133	Motor dependant	Motor dependant	Motor dependant
Start compensation	134	100.0%	100.0%	100.0%
u/F ratio	135	Motor dependant	Motor dependant	Motor dependant
Slip compensation	136	0.00%	100.0%	100.0%
dc holding voltage	137	Off	0%	0%
Brake cut -out frequency	138	3.0HZ	3.0HZ	3.0HZ
Brake cut -in frequency	139	3.0HZ	3.0HZ	3.0HZ
Rotation direction	200	132HZ ctr-clockwise	132HZ ctr-clockwise	132HZ ctr-clockwise
Minimum frequency	201	21HZ	0HZ	0HZ
Maximum frequency	202	50HZ (60 some models)	50HZ (60 some models)	50HZ (60 some models)
Reference/feedback range	203	Min- max	Min- max	Min- max
Minimum reference	204	0HZ	0HZ	(Sensor min)
Maximum reference	205	50HZ (60 some models)	50HZ (60 some models)	(Sensor max)
Ramp up time 1	207	10.00 seconds	10.00 seconds	10.00 seconds
Ramp down time 1	208	3.0 seconds	3.0 seconds	3.0 seconds
Ramp up time 2	209	3.0 seconds	3.0 seconds	3.0 seconds
Ramp down time 2	210	3.0 seconds	3.0 seconds	3.0 seconds
Jog ramp time	211	10.00 seconds	10.00 seconds	10.00 seconds
Quick stop ramp down time	212	3.0 seconds	3.0 seconds	3.0 seconds
Jog frequency	213	50HZ	50HZ	50HZ
Reference function	214	Sum	Sum	Sum
Preset reference 1 (copy of parameter 241)	215	000.00%	000.00%	As required [%]
Preset reference 2	216	000.00%	000.00%	000.00%
Catch up/slow down value	219	000.00%	000.00%	000.00%
Current limit for motor mode	221	100%	100%	100%
Frequency bypass bandwidth	229	Off	Off	Off
Frequency bypass 1	230	0.00 HZ	0.00 HZ	0.00 HZ
Frequency bypass 2	231	0.00 HZ	0.00 HZ	0.00 HZ
Preset reference 1 (copy of parameter 215)	241	000.00%	000.00%	As required [%]
Preset reference 2 - 7	242 - 247	000.00%	000.00%	000.00%

DESCRIPTION	PARAMETER	SENSORLESS	OPEN LOOP	CLOSED LOOP
Time out	317	10 Seconds	10 seconds	10 seconds
Function after time out	318	Off	Off	Stop and trip
x102 relay function	323	Running	Running	Running
Pulse reference/feedback max frequency	327	5000HZ	5000HZ	5000HZ
Terminal 1, analogue input current	331	No Operation	Feedback	Feedback
Terminal 2, digital input	332	Reference	Reference	Reference
Terminal 3, digital input	333	Quick Stop Inverse	Quick stop inverse	Quick stop inverse
Terminal 4, digital input	334	Stop Inverse	Start	Start
Terminal 5, digital input	335	Setup Select	Setup Select	Jogging
Terminal 1, minimum scaling	336	4.0mA	4.0mA	4.0mA
Terminal 1, maximum scaling	337	20.0mA	20.0mA	20.0mA
Terminal 2, minimum scaling	338	0.0V	0.0V	0.0V
Terminal 2, maximum scaling	339	10.0V	10.0V	10.0V
Output functions	340	Fault	Fault	Fault
Brake function	400	OFF	OFF	OFF
Sleep mode timer	403	OFF	OFF	OFF
Sleep frequency	404	0HZ	0HZ	0HZ
Reset function	405	Automatic x 10	Automatic x 10	Automatic x 10
Boost setpoint	406	100%	100%	100%
Wake up frequency	407	50HZ	50HZ	50HZ
Switching frequency	411	8000 HZ	8000 HZ	8000 HZ
Variable switching frequency	412	Temp. dep. frequency	Temp. dep. frequency	Temp. dep. frequency
Overmodulation function	413	ON	ON	ON
Minimum feedback	414	0.00	0.00	(Sensor min)
Maximum feedback	415	4.00	4.00	(Sensor max)
Reference/feedback unit	416	Bar	Bar	(Sensor unit)
Process PID normal/inverse control	437	N/A	N/A	Normal
Process PID anti-windup	438	N/A	N/A	Enable
Process PID start frequency	439	N/A	N/A	20HZ
Process PID proportional gain	440	N/A	N/A	0.5
Process PID integral time	441	N/A	N/A	1.00 second
Process PID differentiation time	442	N/A	N/A	0.00 second
Process PID differentiation gain limit	443	N/A	N/A	5.0
Process PID lowpass filter time	444	N/A	N/A	0.50
Flying start	445	OK same direction	OK same direction	OK same direction
Switching pattern	446	SFAVM	SFAVM	SFAVM
Feedback conversion	461	Linear	Linear	Linear
Bus address	500	1	1	1
Baudrate	501	9600 Baud	9600 baud	9600 baud
Coasting	502	Logic OR	Logic OR	Logic OR
Quick stop	503	Logic OR	Logic OR	Logic OR
dc-brake	504	Logic OR	Logic OR	Logic OR
Start	505	Logic OR	Logic OR	Logic OR
Reversing	506	Logic OR	Logic OR	Logic OR
Selection of setup	507	Logic OR	Logic OR	Logic OR
Selection of speed	508	Logic OR	Logic OR	Logic OR
Bus jog 1	509	10.0HZ	10.0HZ	10.0HZ
Bus jog 2	510	10.0HZ	10.0HZ	10.0HZ
Telegram profile	512	Fc drive profile	Fc drive profile	Fc drive profile
Bus time interval	513	1 Second	1 second	1 second
Bus time interval function	514	OFF	OFF	OFF
Serial communication parameters	515 - 543	Read out only parameters - not editable		
Technical function parameters	600 - 635	Read out only parameters - not editable		
Sensorless control	700	ON	OFF	OFF
Power error	701	20W	20W	20W
Delta frequency	702	0.2HZ	0.2HZ	0.2HZ
Integral power	703	20	20	20
Integral frequency	704	20	20	20
Quadratic head	705	ON	ON	ON
Head Q _{min}	707	40%	40%	40%
Power consumption	708	0W	0W	0W
Temperature rise rated	710	80°C	80°C	80°C
TAU therm	711	300 seconds	300 seconds	300 seconds
Slip 0°C	712	0	0	0
Slip 100°C	713	0	0	0
Head working point	716	Default	Default	Default
Flow working point	717	Default	Default	Default
Head Q _{max}	798	Default	Default	Default

9.0 WARNINGS AND ALARMS

There are two means of notification of warnings and alarms on an Design Envelope pump. The keypad tool (LCP) will display alarm information and in addition to this there are five status LED's that can be viewed on removal of the inverter cover (see figure 2, page 3). The table below gives the different warnings and alarms and indicates whether the fault locks the pump. After Trip locked, the mains supply must be cut and the fault must be

corrected. Reconnect the mains supply and reset (auto-reset by default) the pump before starting. Wherever a cross is placed under both Warning and Alarm, this can mean that a warning precedes the alarm. It can also mean that it is possible to program whether a given fault is to result in a warning or an alarm. After a trip, alarm and warning will flash, but if the fault is removed, only alarm will flash. After a reset, the pump will be ready to start operation again.

NO.	DESCRIPTION	WARNING	TRIP ALARM	TRIP LOCKED
2	Live zero fault (Live zero error)	x	x	
4	Phase loss (Mains phase loss)	x	x	x
5	Voltage warning high (dc Link voltage high)	x		
6	Voltage warning low (dc Link voltage low)	x		
7	Overvoltage (dc Link overvolt)		x	x
8	Undervoltage (dc Link undervolt)		x	
9	Inverter overload (Inverter time)	x	x	
11	Motor thermistor (Motor thermistor)		x	
12	Current limit (Current limit)	x		
13	Overcurrent (Over temperature)		x	x
14	Earth fault (Earth fault)		x	x
15	Supply fault (Switch mode fault)		x	x
16	Short-circuit (Curr.short circuit)		x	x
17	Standard bus timeout (STD Bus timeout)	x	x	
18	Hpfb bus timeout (HPFB timeout)	x	x	
33	Out of frequency range (Out freq RNG/ROT LIM)	x		
34	HPFB error (HPFB alarm)	x	x	
35	Inrush fault (Inrush fault)		x	x
36	Overtemperature (Over temperature)	x	x	
37	Internal error (Internal error)		x	x

WARNINGS

The display flashes between normal state and warning. A warning comes up on the first and second line of the display.

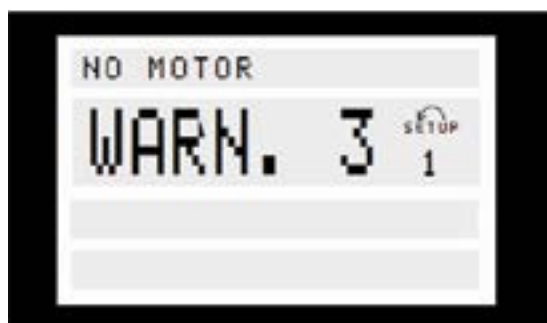

ALARMS

The alarm comes up in the 2. and 3. line of the display.

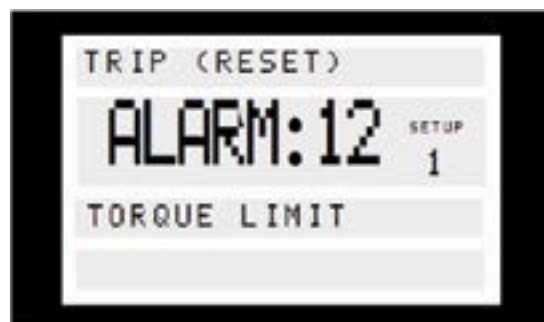

WARNING/ALARM 2, Live zero fault (Live zero error):

The current signal on terminal 1 is less than 50% of the value set in parameter 336 Terminal 1, min. scaling .

WARNING/ALARM 4, Phase loss (Mains phase loss):

Phase missing on the supply side. Check the supply voltage to the inverter.

WARNING 5, Voltage warning high (Dc link voltage high):

The intermediate circuit voltage (DC) is higher than the overvoltage limit of the control system, see table on the next page. The inverter is still active.

WARNING 6, voltage warning low (DC link voltage low):

The intermediate circuit voltage (DC) is below the undervoltage limit of the control system, see table on the next page. The inverter is still active.

ALARM 7, overvoltage (DC over voltage):

If the intermediate circuit voltage (DC) exceeds the inverter overvoltage limit (see table on the next page), the inverter will trip. Furthermore, the voltage will be stated in the display.

ALARM 8, Undervoltage (DC under voltage):

If the intermediate circuit voltage (DC) drops below the inverter lower voltage limit (see table on this page), the inverter will trip after 3 - 28 sec., depending on unit. Furthermore, the voltage will be stated in the display. Check whether the supply voltage matches inverter motor.

WARNING/ALARM 9, Inverter overload (Inverter time):

The electronic, thermal inverter protection reports that the inverter is about to cut out because of an overload (too high current for too long). The counter for electronic, thermal inverter protection gives a warning at 95% and trips at 100%, while giving an alarm. The inverter cannot be reset until the counter is below 90%.

TRIP/ALARM/WARNING LIMITS:

FC motor Series	3 × 380 – 480
Undervoltage	410[VDC]
Voltage warning low	440[VDC]
Voltage warning high	760[VDC]
Overvoltage	760[VDC]*

*760v in 5 sec. or 800v immediately.

The voltages stated are the intermediate circuit voltage of the inverter.

ALARM 11, Motor thermistor (Motor thermistor):

If a thermistor is mounted and parameter 128 is set to Enable [1], the FC motor will trip if the motor gets too hot..

WARNING 12, Current limit (Current limit):

The current is higher than the value in parameter 221 (in motor operation).

ALARM 13, Over Current (Over Current):

The inverter peak current limit (approx. 230% of the rated current) has been exceeded. The inverter will trip, while giving an alarm. Turn off the inverter and check whether the motor shaft can be turned.

ALARM 14, Earth fault (Earth fault):

There is a discharge from the output phases to earth, either between the inverter and the motor or in the motor itself.

ALARM 15, Supply fault (Switch mode fault):

Fault in the switch mode power supply (internal 24 v supply). Contact Armstrong.

ALARM 16, Short-circuiting (Curr. short circuit):

There is short-circuiting on the motor terminals or the motor itself. Contact Armstrong.

ALARM 17, Standard bus timeout (STD Bus timeout):

There is no communication to the inverter (when using serial communications). The warning will only be active when parameter 514 has been set to another value than OFF. If parameter 514 has been set to stop and trip, it will first give a warning and then ramp down until it trips, while giving an alarm.

Parameter 513 Bus time interval could possibly be increased.

WARNING 33, Out of frequency range:

This warning is active if the output frequency has reached parameter 201 Output frequency low limit or parameter 202 Output frequency high limit.

WARNING/ALARM 34, HPFB error (HPFB alarm):

The profibus communication is not working correctly.

ALARM 35, Inrush fault (Inrush fault):

This warning occurs when the unit has been switched on too many times within one minute.

WARNING/ALARM 36, Over temperature (Over temperature):

A warning occurs at 78°C and the inverter trips at 90°C. The unit can be reset when the temperature is below 70°C.

ALARM: 37 Internal error (Internal error):

An error has occurred in the system. Contact Armstrong.

9.1 INTERNAL LED DESCRIPTIONS

The LED's (shown in figure 4, page 15) can be used to determine the status of the Design Envelope pump when an LCP is not available.

SAFETY, RISK OF DEATH



To view the LED's the cover will need to be removed with the power supply switched on. This is very dangerous and all necessary precautions should be taken to eliminate the risk of electrocution.

LED 300-304

- LED 300 (red): Fault trip
- LED 301 (yellow): Warning
- LED 302 (green): Power on
- LED 303-304: Communication (LCP or RS485)

NOTE:

If LED301 flashes slowly then the pump has been given a stop command via an LCP (keypad) and can only be started by an LCP start command.

FAULT FINDING CHART - KEYPAD AVAILABLE

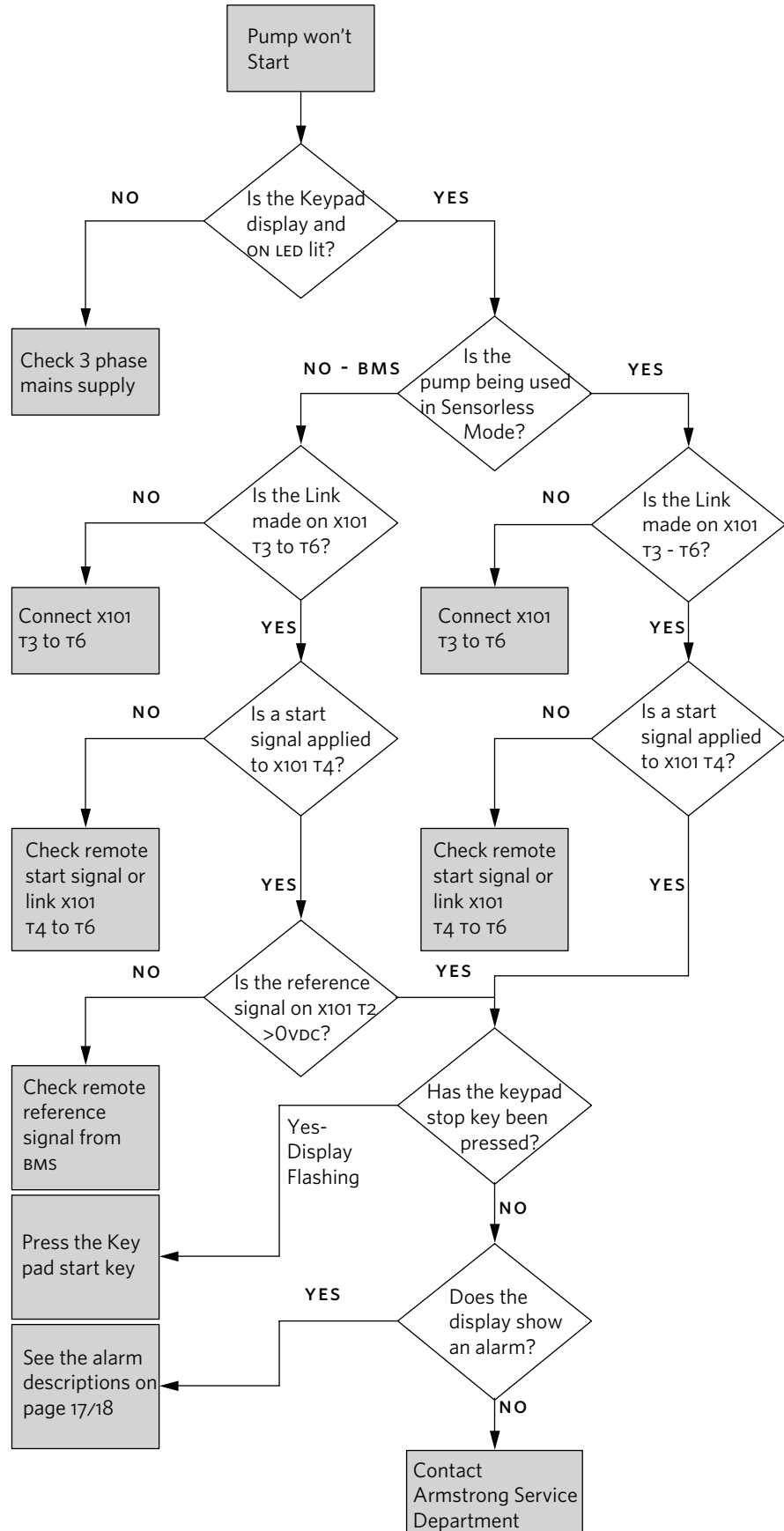

FAULT FINDING CHART - NO KEYPAD AVAILABLE

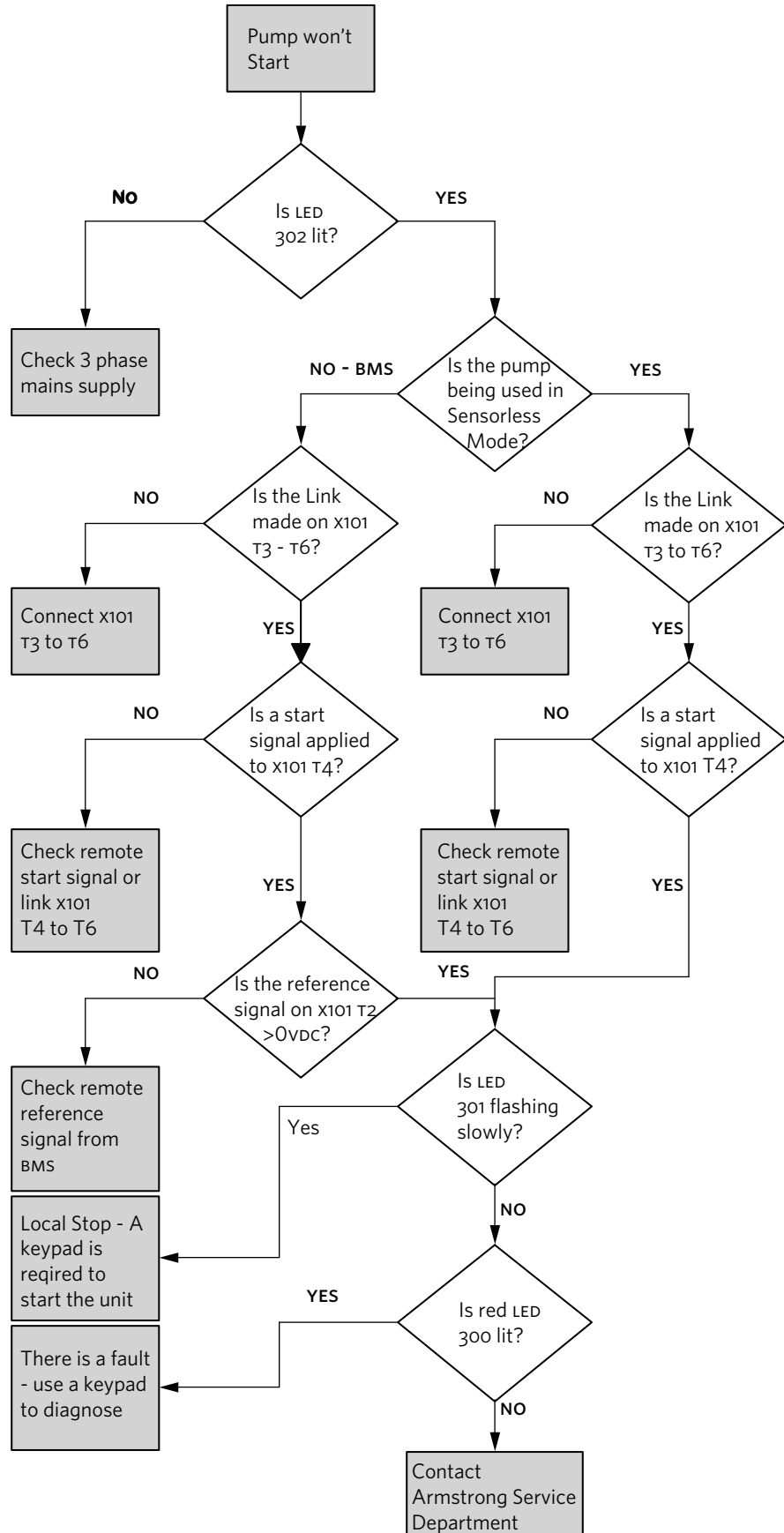

10.0 INTEGRATED CONTROLS

10.1 ENCLOSURE RATING



The standard enclosure rating for Design Envelope 4300 and 4380 integrated controls is IEC IP55. If the pump is to be installed in a wet or dusty environment then a higher enclosure rating may be required (contact Armstrong)

10.2 AMBIENT TEMPERATURE



To avoid the inverter unit getting overheated, the ambient temperature is not to exceed 133°F (45°C). Operating in higher ambient temperatures will require derating of the inverter.

11.0 ELECTRICAL INSTALLATION



All electrical connections should be carried out by a qualified and authorized electrician in accordance with local site regulations and the latest issue of the IEE regulations.

SAFETY, RISK OF DEATH



Before removing the controls cover, the system must be disconnected from the mains supply. After switching off, wait for at least 15 minutes for the capacitors to discharge before opening the cover.

CAUTION



High voltage testing (Megging) of the motor/ controls may cause damage to the electronic components and therefore should not be carried out

11.1 GROUND LEAKAGE CURRENT



Ground leakage current is primarily caused by the capacitance between motor phases and the motor frame. The RFI filter contributes additional leakage current, as the filter circuit is connected to ground through capacitors.

The size of the leakage current to the ground depends on the following factors, in order of priority:

- 1 Switching frequency
- 2 Motor grounded on site or not

The leakage current is of importance to safety during handling / operation of the Design Envelope pump if (by mistake) the on-board inverter has not been grounded.



Since the leakage current is >3.5mA (approx 4-20mA), reinforced grounding must be established which is required by local wiring standards is to be complied with. Never use ELCB relays that are not suitable for DC fault currents (type A).

If ELCB relays are used, they must be:

- Suitable for protecting equipment with a direct current content (DC) in the fault current (three-phase bridge rectifier)
- Suitable for power-up with short charging current to ground
- Suitable for a high leakage current

11.2 START / STOP OF PUMP

The number of starts/stops via the mains voltage must not exceed one-time per minute.

If a higher number of starts/stops is required then the start/stop digital input must be used (mains voltage directly connected). This is the preferred method of starting and stopping Design Envelope pumps.

The three phase mains must be isolated before performing maintenance of the pump.

11.3 ADDITIONAL MOTOR PROTECTION



With the exception of supply fuses / MCB's to protect the installation (for over-current and short-circuit protection), no additional overload or over-temperature protection is required (i.e. thermal overloads). Protection features include:

- Mains phase loss
- Over voltage
- Under voltage
- Electronic thermal motor protection
- Short circuit on motor terminals
- Ground fault on motor terminals
- Over temperature

11.4 SUPPLY VOLTAGE

The supply voltage details can be found on the inverter nameplate. Please ensure that the unit is suitable for the electrical supply on which it is to be used. The mains supply for Design Envelope pumps is as follows:

3 × 380-480V +/- 10%

Supply frequency - 50HZ

11.5 SUPPLY FUSING

Branch circuit protection

In order to protect the installation against electrical and fire hazard, all branch circuits in an installation, switch gear, machines etc., must be short-circuit and over-current protected according to the national/international regulations.

Short circuit protection

The inverter must be protected against short-circuit to avoid electrical or fire hazard. Armstrong recommends using the fuses detailed in the separate **ivs102 Operating Instructions** to protect service personnel or other equipment in case of an internal failure in the unit. The frequency converter provides full short circuit protection in case of a short-circuit on the motor output.

11.6 GROUNDING AND IT MAINS



The ground connection cable cross section must be at least 10 mm² or two rated mains wires terminated separately according to local wiring standards. Always comply with national and local regulations on cable cross sections.



The mains is connected to the main disconnect switch if this has been included.



Check the mains voltage corresponds to the mains voltage of the frequency converter name plate.

IT MAINS

Do not connect frequency converters with RFI-filters



to mains supplies with a voltage between phase and earth of more than 440v for 400v converters. For 440V IT MAINS and delta earth (grounded leg), mains voltage may exceed 440v between phase and earth.

FIG. 4 Terminals for mains and grounding

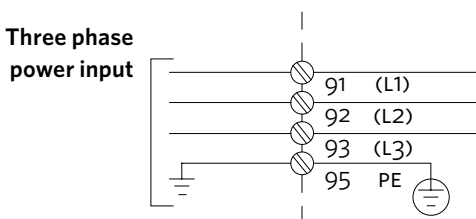

FIG. 5 Mains and grounding connections for A5 units (380-480v 7.5kW and below)

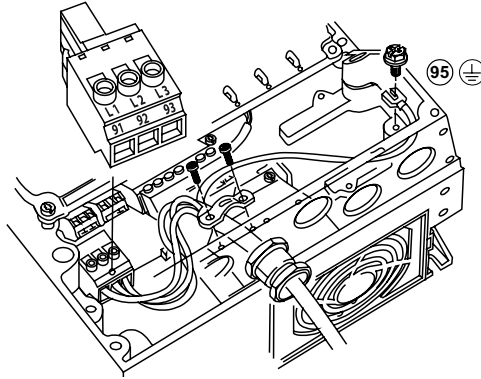

FIG. 6A Mains and grounding connections for B1 and B2 units (380-480v - 11 TO 30 kW)

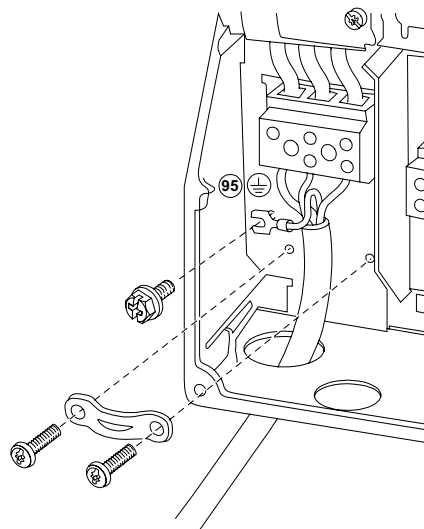

FIG. 6B Mains and grounding connections for C1 and C2 units (380-480v - 37 TO 90kW)

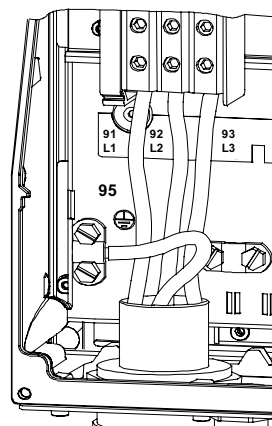
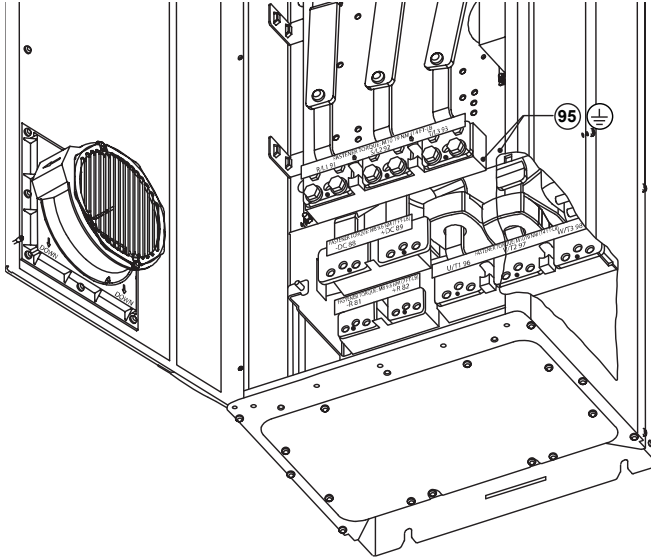

FIG. 4C Mains and grounding connections for D1 and D2 units (380-480V - 110 to 315kW)



The following illustrations identify the location of the relays within specific inverter sizes:

The illustrations in **FIG. 6, 7** and **8** identify the location of the relays within specific inverter sizes:

FIG. 8 Relay connection: terminals for A5, B1 and B2 units

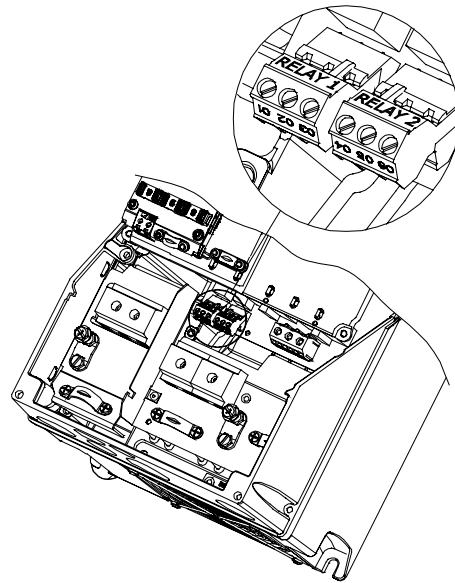

11.7 RELAY CONNECTIONS

The relays on the Design Envelope are configured as follows:

RELAY 1 - RUNNING

- Terminal 01: Common
- Terminal 02: Normal open 240V AC
- Terminal 03: Normal closed 240V AC

RELAY 2 - ALARM

- Terminal 04: Common
- Terminal 05: Normal open 400V AC
- Terminal 06: Normal closed 240V AC

FIG. 7 Relay contact details

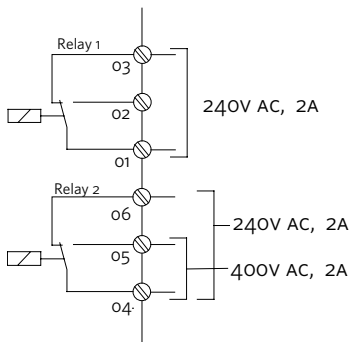

FIG. 9 Relay connection terminals for C1 and C2 units

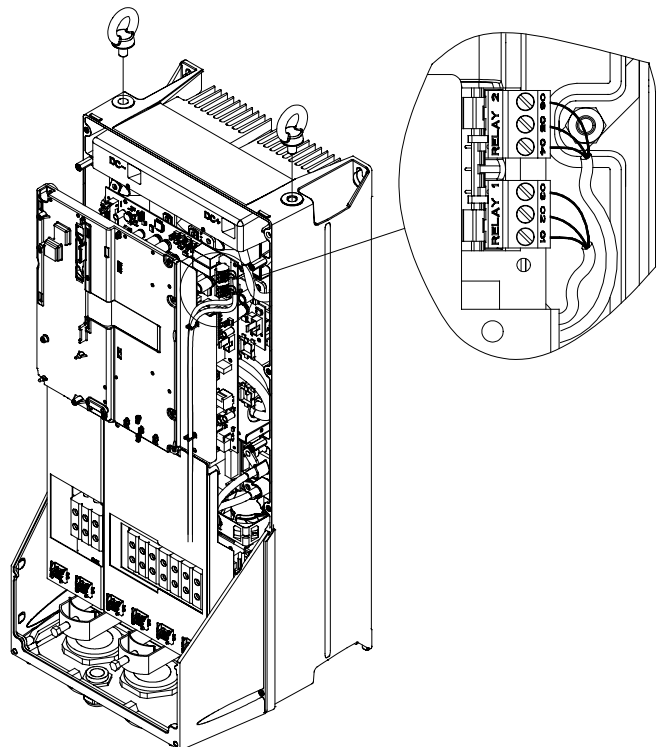
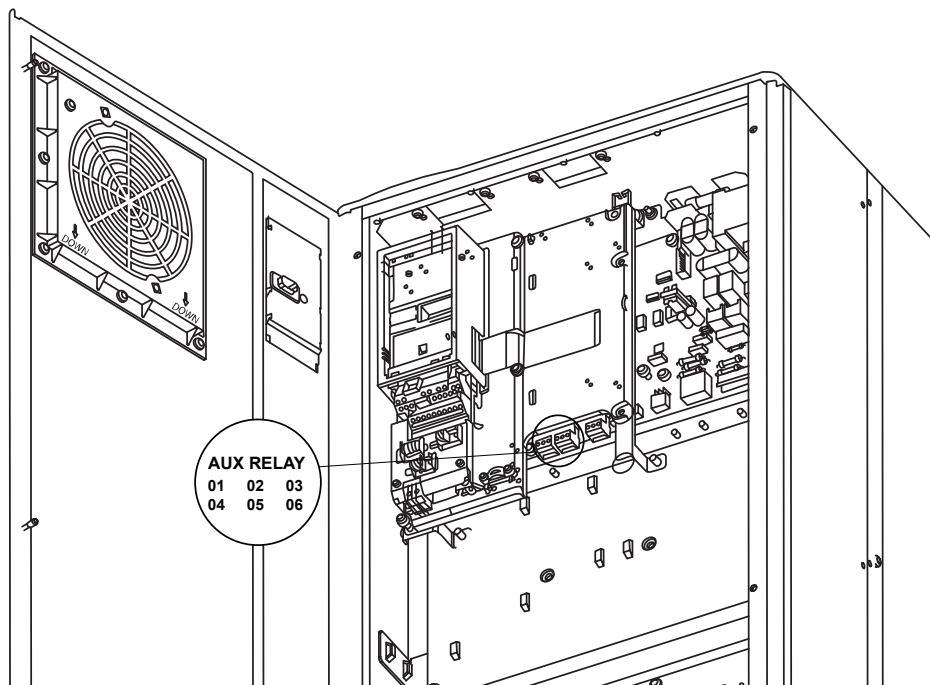

FIG. 8 Relay connection terminals for c1 and c2 units



11.8 CONNECTION TIGHTENING TORQUES

11.8.1 TORQUES SETTINGS (1.1-90kW DRIVES)

Tightening of Terminals

ENCLOSURE	Power [kW]			Torque [Nm]					
	200-240 V	380-480/500 V	525-600 V	LINE POWER	MOTOR	DC CONNECTION	BRAKE	GROUND	RELAY
A2	0.25-2.2	0.37-4.0		1.8	1.8	1.8	1.8	3	0.6
A3	3.0-3.7	5.5-7.5	0.75-7.5	1.8	1.8	1.8	1.8	3	0.6
A4	0.25-2.2	0.37-4.0		1.8	1.8	1.8	1.8	3	0.6
A5	0.25-3.7	0.37-7.5	0.75-7.5	1.8	1.8	1.8	1.8	3	0.6
B1	5.5-7.5	11-15	11-15	1.8	1.8	1.5	1.5	3	0.6
B2	11	18	18	4.5	4.5	3.7	3.7	3	0.6
		22	22	4.5	4.5	3.7	3.7	3	0.6
B3	5.5-7.5	11-15	11-15	1.8	1.8	1.8	1.8	3	0.6
B4	11-15	18-30	18-30	4.5	4.5	4.5	4.5	3	0.6
C1	15-22	30-45	30-45	10	10	10	10	3	0.6
C2	30-37	55-75	55-75	14/24 ¹⁾	14/24 ¹⁾	14	14	3	0.6
C3	18-22	37-45	37-45	10	10	10	10	3	0.6
C4	30-37	55-75	55-75	14/24 ¹⁾	14/24 ¹⁾	14	14	3	0.6

NOTE: 1) For different cable dimensions x/y, where $x \leq 95 \text{ mm}^2$ and $y \geq 4/0 \text{ 95 mm}^2$.

11.8.2 TORQUES SETTINGS (>90KW DRIVES)

When tightening electrical connections, it is important to use a torque wrench to obtain the correct torque. Torque that is too low or too high results in a bad electrical connection.

See the torque settings in Table

FRAME SIZE	TERMINAL	SIZE	TORQUE NOMINAL [NM (IN-LBS)]	TORQUE RANGE [NM (IN-LBS)]	
D1h/D3h/ D5h/D6h	Line power	M10	29.5 (261)	19-40 (168-354)	
	Motor				
	Load sharing				
	Regeneration				
	Ground	M8	14.5 (128)	8.5-20.5 (75-181)	
	Brake				
D2h/D4h/ D7h/D8h	Line power	M10	29.5 (261)	19-40 (168-354)	
	Motor				
	Regeneration				
	Load Sharing				
	Ground	M8		8.5-20.5 (75-181)	
	Brake				
E	Line power	M10	19.1 (169)	17.7-20.5 (156-182)	
	Motor				
	Load Sharing				
	Ground				
	Regen	M8	9.5 (85)	8.8-10.3 (78.2-90.8 in-lbs.)	
	Brake				
F	Line power	M10	19.1 (169)	17.7-20.5 (156-182 in-lbs.)	
	Motor				
	Load Sharing				
	Regen:	DC-	M8	9.5 (85)	8.8-10.3 (78.2-90.8)
		DC+	M10	19.1 (169)	17.7-20.5 (156-182)
	F8-F13 Regen	M10	19.1 (169)	17.7-20.5 (156-182.)	
	Ground	M8	9.5 (85)	8.8-10.3 (78.2-90.8)	
	Brake				

11.9 ELECTRICAL INSTALLATION AND CONTROL CONNECTIONS

FIG. 9 Diagram showing all electrical connections

*Note: terminal 37 is not available on Design Envelope pumps

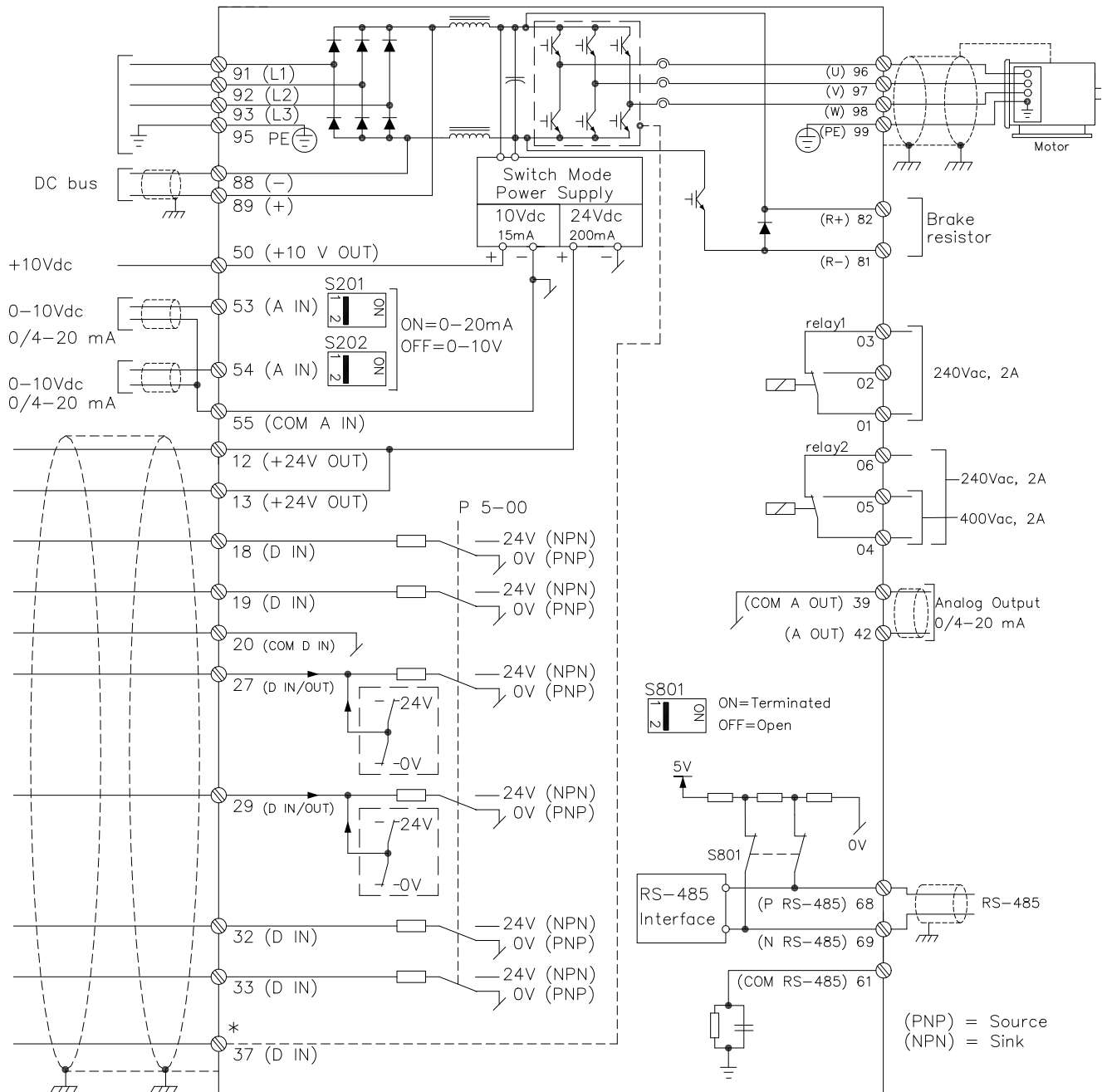

11.9.1 ACCESS TO TERMINALS

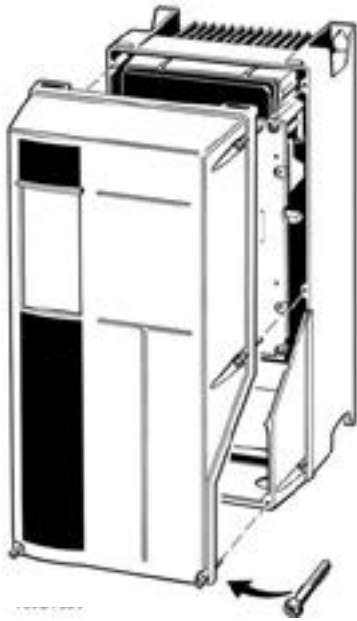

Remove front-cover to access control terminals. For D1 and D2 chassis IVS 102 units access swings open. (see Fig. 2.13). When replacing the front cover, please ensure proper fastening by applying a torque of 2 Nm.

11.9.2 CONTROL TERMINALS

With reference to figure 10:

FIG. 10 CONTROL CONNECTIONS

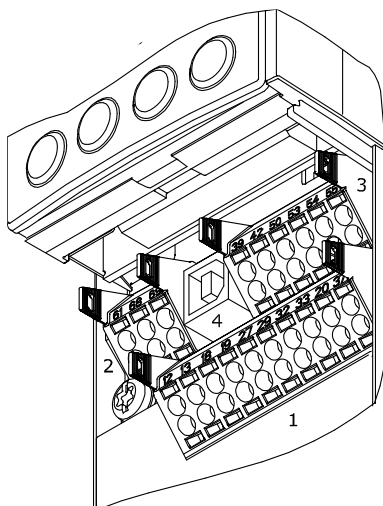

- 1 10-way plug for digital I/O
- 2 3-way plug for RS485 bus
- 3 6-way plug for analogue I/O
- 4 USB connection

Control terminal functions and factory settings are as follows:

TERMINAL NO.	TYPE / DESCRIPTION	FACTORY SETTING
1,2,3	Relay 1	Running
4,5,6	Relay 2	Alarm
12	Supply	+24V DC
13	Supply	+24V DC
18	Digital input	Start
19	Digital input	Pump operating mode
20	Common	OK
27	Digital input	Low water interlock
29	Digital input	No operation
32	Digital Input	No operation
33	Digital input	No operation
37	Digital input	No operation
42	Analogue output	Output frequency (4-20mA - 0-100Hz)
53	Analogue input	Reference (0-10V)*
54	Analogue input	Feedback (0-10V)*

*Note that Analogue inputs AI53 and AI54 can be either Voltage (0-10V) or Current (4-20mA) input and by default both inputs are set to Voltage. Switches S201 and S202 (see figure 9) are used to configure the analogue inputs as follows:

- S201 (AI53) off = Voltage, on = Current
- S202 (AI54) off = Voltage, on = Current

Inserting Cables into Control Terminals

- I Strip 10mm of insulation from the cable:
- II Insert a suitable terminal screwdriver as shown and then push the cable into the terminal.
- III Remove the terminal screwdriver and check the terminal has gripped the cable by gently pulling it.

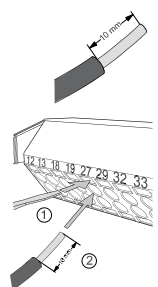

Note: Terminal plugs can be easily removed for improved access when making connections.

11.9.3 CONNECTION EXAMPLES

Design Envelope pumps can be configured in four main ways:

- I Sensorless
 - II Closed loop - with feedback sensor
 - III Constant curve mode - Potentiometer Control
 - IV Constant curve mode - BMS signal
- IV.1 Full speed override**

I SENSORLESS

Design Envelope pumps are factory configured to be connected as shown below.

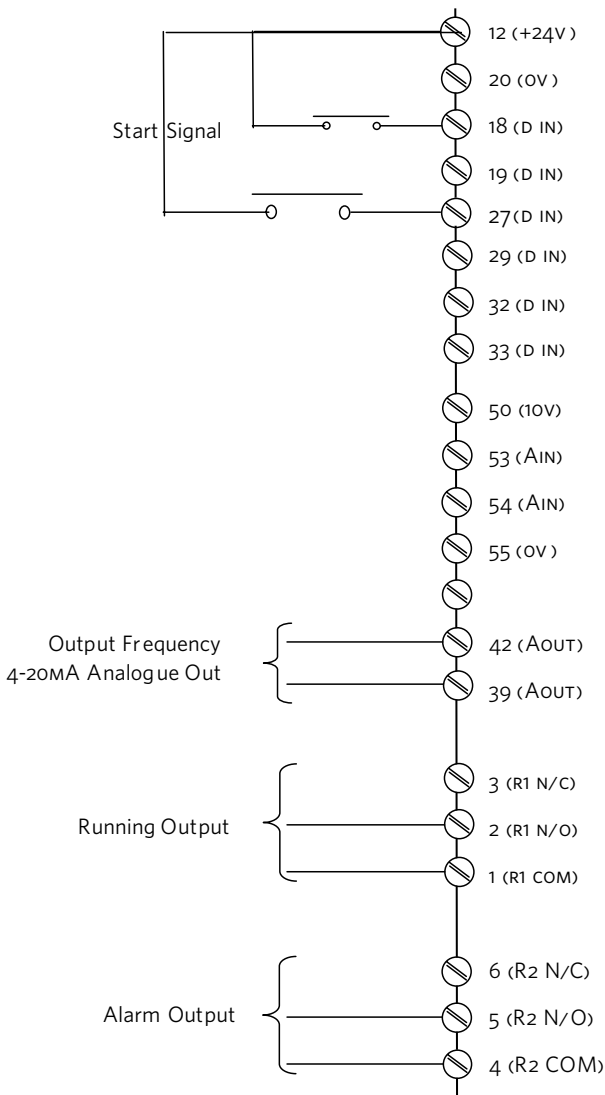

II CLOSED LOOP - WITH SENSOR FEEDBACK

To control the pump based on a 4-20mA feedback signal from a sensor use the following connection.

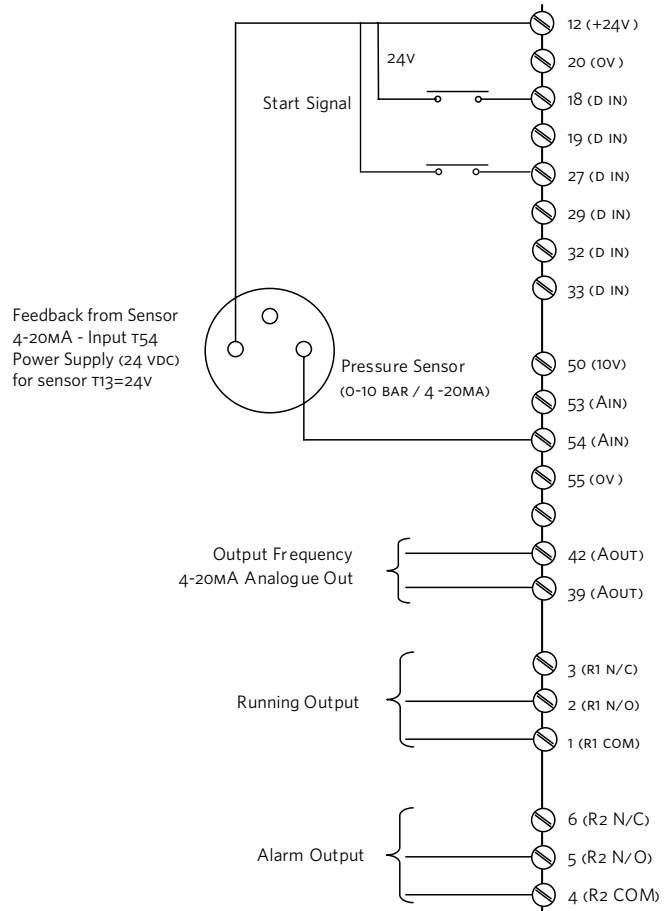

III CONSTANT CURVE MODE - BMS SIGNAL

When the Building Management System is to be used for speed control it is necessary to disable sensorless control and provide the unit with a 0-10VDC speed reference signal.

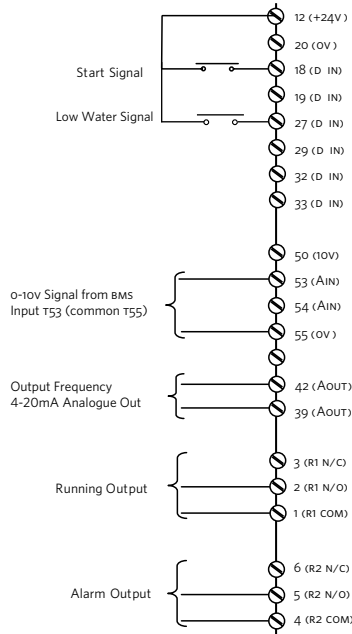

IV CONSTANT CURVE MODE - POTENTIOMETER

To control the pump based on a 0-10V potentiometer signal use the connections below.

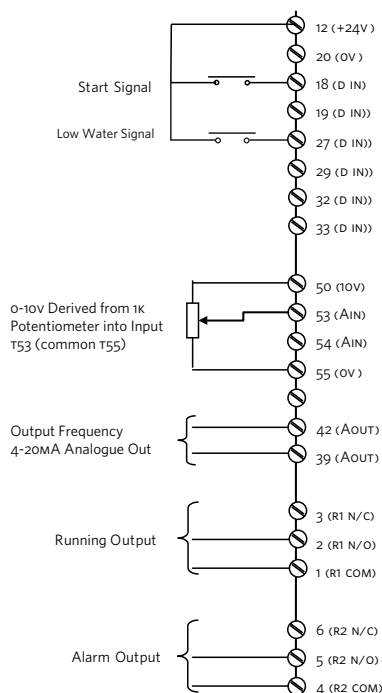

IV.1 FULL SPEED OVER RIDE

It may be required to run the pump at full speed without automatic speed control (eg during system commissioning). This can be achieved without programming changes by making the connections below.

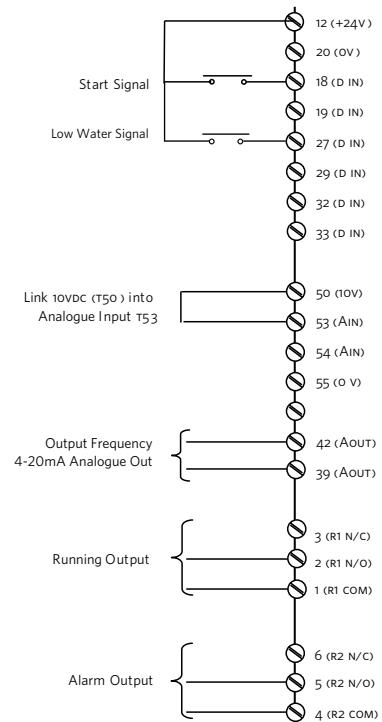

11.9.4 REMOTE LCP KEYPAD WIRING

For large Design Envelope units with remote LCP keypad, see wiring arrangement below.

LCP WIRING ARRANGEMENT

TERMINAL	WIRE COLOR
1	Green
2	Brown
3	Red
4	Yellow
5	Black
6	Orange
7	Blue
8	Purple
9	Grey



12.0 PROGRAMMING, MONITORING AND DIAGNOSTICS

Design Envelope pumps incorporate an integrated graphical local control panel (GLCP).

12.1 GLCP FUNCTIONS AND OPERATION

The GLCP is divided into four functional groups:

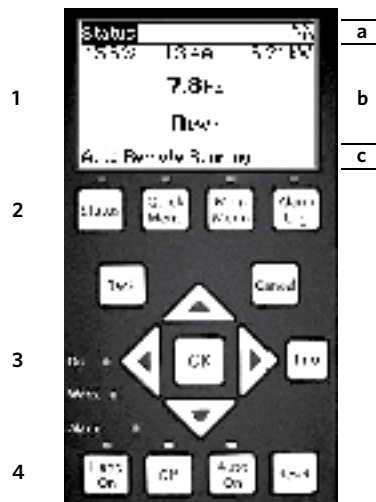

- 1 Graphical display with status lines.
- 2 Menu keys and indicator lights (LEDs) – selecting mode, changing parameters and switching between display functions.
- 3 Navigation keys and indicator lights (LEDs).
- 4 Operation keys and indicator lights (LEDs).

Graphical display:

The LCD-display is back-lit with a total of six alpha-numeric lines. All data is displayed on the LCP which can show up to five operating variables while in **Status** mode.

Display lines:

- a Status line:** Status messages displaying icons and graphics.
- b Line 1-2:** Operator data lines displaying data and variables de-fined or chosen by the user. By pressing the **Status** key, up to one extra line can be added.
- c Status line:** Status messages displaying text.

The display is divided into three sections:

Top section (a) shows the status when in status mode or up to two variables when not in status mode and in the case of ALARM/WARNING.

The number of the Active set-up (Sensorless mode being setup 1) is shown.

The middle section (b) shows up to five variables with related unit, regardless of status. In case of alarm/warning, the warning is shown instead of the variables.

The Bottom section (c) always shows the state of the inverter in Status mode.

It is possible to toggle between three status read-out displays by pressing the **Status** key.

Operating variables with different formatting are shown in each status screen — see below.

Status display I:

This read-out state is standard after start-up or initialisation. Use **Info** to obtain information about the value/measurement linked to the displayed operating variables (1.1, 1.2, 1.3, 2 and 3). See the operating variables shown in the display in this illustration. 1.1,1.2 and 1.3 are shown in small size. 2 and 3 are shown in medium size.

Status display II:

See the operating variables (1.1, 1.2, 1.3 and 2) shown in the display in this illustration.

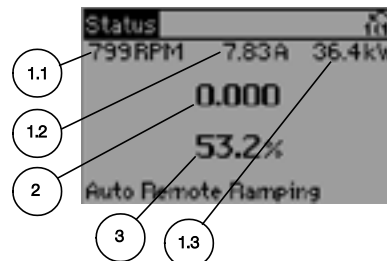

In the example, Speed, Motor current, Motor power and Frequency are selected as variables in the first and second lines. 1.1, 1.2 and 1.3 are shown in small size. 2 is shown in large size.

Display Contrast Adjustment

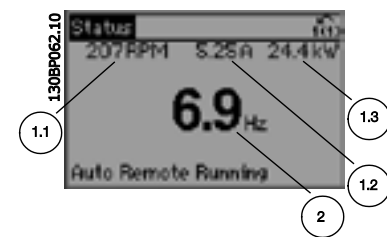

- Press **Status** and [▲] for darker display
- Press **Status** and [▼] for brighter display

12.2 INDICATOR LIGHTS (LEDS)

If certain threshold values are exceeded, the alarm and/or warning LED lights up. A status and alarm text appear on the control panel. The **ON** LED is activated when the frequency converter receives power from mains voltage, a DC BUS terminal, or an external 24v supply. At the same time, the back light is on.

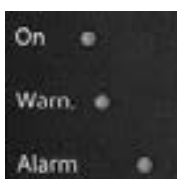

- Green led/**ON**: Control section is working.
- Yellow led/**WARN.**: Indicates a warning.
- Flashing Red led/**ALARM**: Indicates an alarm.

12.3 CONTROL KEYS

Menu keys

The menu keys are divided into functions. The keys below the display and indicator lamps are used for parameter set-up, including choice of display indication during normal operation.



Status

Indicates the status of the frequency converter and/or the motor. Three different readouts can be chosen by pressing the **Status** key: five line readouts, four line readouts or Smart Logic Control.

Use **Status** for selecting the mode of display or for changing back to Display mode from either the Quick Menu mode, the Main Menu mode or Alarm mode. Also use the **Status** key to toggle single or double read-out mode.

Quick Menu

Allows quick set-up of the inverter by access to a limited number of parameters. Quick Menu does not include all the parameters that may need to be changed when utilising Sensorless control and it is therefore recommended that parameter changes are made in Main Menu mode.

Main Menu

Is used for programming all parameters.

Alarm Log

Displays an Alarm list of the five latest alarms (numbered A1-A5). To obtain additional details about an alarm, use the arrow keys to manoeuvre to the alarm number and press **OK**. Information is displayed about the condition of the frequency converter before it enters the alarm mode.

The Alarm log button on the LCP allows access to both Alarm log and Maintenance log.

Back

Reverts to the previous step or layer in the navigation structure.

Cancel

Last change or command will be cancelled as long as the display has not been changed.

Info

Displays information about a command, parameter, or function in any display window. **Info** provides detailed information when needed.



Navigation Keys

The four navigation arrows are used to navigate between the different choices available in **Quick Menu**, **Main Menu** and **Alarm Log**. Use the keys to move the cursor.

OK

Is used for choosing a parameter marked by the cursor and for enabling the change of a parameter.

Operation Keys for local control are found at the bottom of the control panel.



Hand On

Enables control of the pump via the GLCP. It is possible to enter the pump speed data by means of the arrow keys.

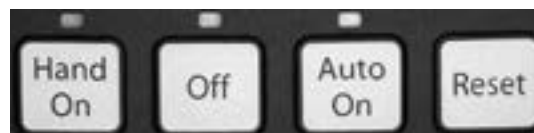

44



The low water device input must be made for the pump to start in either hand mode or auto mode.

Off

Stops the pump.

Auto On

Enables the pump to be controlled via the control terminals and/or serial communication. When a start signal is applied on the control terminals the pump will start.



For the pump to operate in either Sensorless mode or any other automatic control mode it is necessary to have pressed the **Auto On** button.

Reset

Is used for resetting the frequency converter after an alarm (trip).

12.4 PROGRAMMING

Select the Main Menu mode by pressing the **Main Menu** key. The below read-out appears on the display. The middle and bottom sections on the display show a list of parameter groups which can be chosen by toggling the up and down buttons.

Each parameter has a name and number which remain the same regardless of the programming mode. In the Main Menu mode, the parameters are divided into groups. The first digit of the parameter number (from the left) indicates the parameter group number.

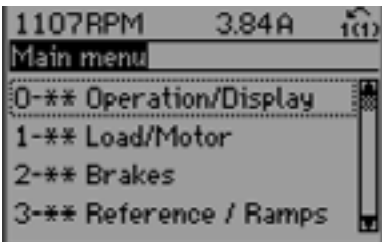

All parameters can be changed in the Main Menu. However, depending on the choice of configuration (Par.1-00 Configuration Mode), some parameters can be hidden.

12.4.1 PARAMETER SELECTION

In the Main Menu mode, the parameters are divided into groups. You select a parameter group by means of the navigation key

The following parameter groups are accessible:

GROUP NO.	PARAMETER GROUP	GROUP NO.	PARAMETER GROUP
0	Operation/display	13	Smart Logic
1	Load/motor	14	Special functions
2	Brakes	15	FC information
3	References/ramps	16	Data readouts
4	Limits/warnings	18	Data readouts 2
5	Digital in/out	20	Drive closed loop
6	Analog in/out	21	Ext. closed loop
8	Com. and options	22	Application functions
9	Profibus	23	Time-based functions
10	CAN Fieldbus	25	Cascade controller
11	LonWorks	26	Analog I/O option MCB 109

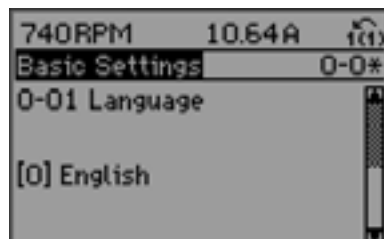

After selecting a parameter group, choose a parameter by means of the navigation keys.

The middle section on the display shows the parameter number and name as well as the selected parameter value.

12.4.2 CHANGING DATA

The procedure for changing data depends on whether the selected parameter represents a numerical data value or a text value.

Changing a text value

If the selected parameter is a text value, change the text value by means of the [▲] [▼] navigation keys.

The up key increases the value, and the down key decreases the value.

Place the cursor on the value you want to save and press **OK**.



Changing Numeric Data Values

If the chosen parameter represents a numeric data value, change the chosen data value by means of the [◀] [▶] navigation keys as well as the [▲] [▼] navigation keys.



Use the [◀] [▶] navigation keys to move the cursor horizontally.

Use the [▲] [▼] navigation keys to change the data value. The up key enlarges the data value, and the down key reduces the data value. Place the cursor on the value you want to save and press **OK**.

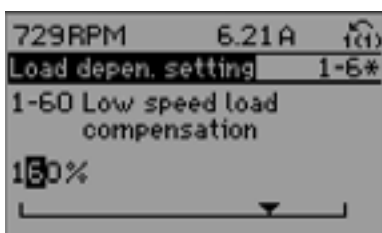

Readout and Programming of Indexed Parameters

Parameters are indexed when placed in a rolling stack.

Par.15-30 Alarm Log: Error code to Par.15-33 Alarm Log: Date and time contain a fault log which can be read out. Choose a parameter, press **OK**, and use the up/down navigation keys to scroll through the value log.

Use Par.3-10 Preset Reference as another example:

Choose the parameter, press **OK**, and use the up/down navigation keys to scroll through the indexed values. To change the parameter value, select the indexed value and press **OK**. Change the value by using the up/down keys. Press **OK** to accept the new setting. Press **Cancel** to abort.

Press **Back** to leave the parameter.

13.0 SENSORLESS OPERATION

Sensorless control is an innovative concept in circulating pumps. Pump performance and characteristic curves are embedded in the memory of the speed controller during manufacture. This data includes power, speed, head and flow across the flow range of the pump. During operation, the power and speed of the pump are monitored, enabling the controller to establish the hydraulic performance and position in the pumps head-flow characteristic.

These measurements enable the pump to continuously identify the head and flow at any point in time, giving accurate pressure control without the need for external feedback signals. Patented software technology within the controller ensures trouble-free operation in all conditions.

Incorporating the pumps hydraulic data into the controller and removing sensors results in true integration of all components and removes the risk of sensor failure.

13.1 DEFAULT OPERATING MODE — QUADRATIC PRESSURE CONTROL

The default control mode for Design Envelope pumps is 'Quadratic Pressure Control' where the controller is set to control the speed according to a 'control curve' between max and min flow (see below diagram). It is widely recognised that fitting a differential pressure sensor at the most remote load, across the supply piping and return piping encompassing the valve & coil set, is the benchmark scheme for energy efficiency.

FIG. 11 QUADRATIC CONTROL SETTINGS

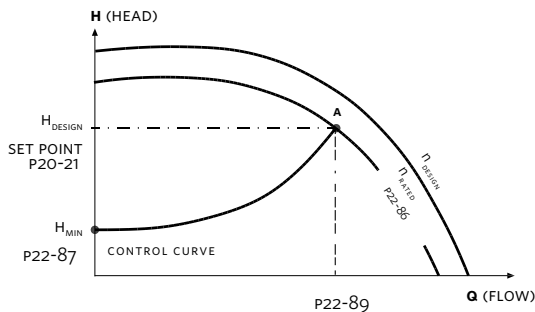

Design Envelope pumps can replicate this control without the need for the remote sensor. As the flow required by the system is reduced, the pump automatically reduces the head developed according to the pre-set control curve.

It is often found that using a remote differential pressure sensor to sense the pressure across a remote load could theoretically result in loads close to the pump being under-pumped. The situation would be where the load at a loop extremity is satisfied and the control valve closes while a load close to the pump needs full flow. The probability of this occurring is remote but it is possible. One answer to this is to move the sensor closer to the pump (two-thirds out in the system is a popular recommendation) although physically re-positioning the sensor at commissioning stage can be a costly exercise. With Sensorless pump control it is possible to replicate the moving of a sensor by increasing the head setting H_{MIN} .

13.1.1 SETTINGS FOR QUADRATIC (CONTROL CURVE) PRESSURE CONTROL

The design duty head and flow of the pump (provided at time of order) is shown as point 'A' in figure 11 in column 1.

FIG. 12 CURVE APPROXIMATION SETTINGS

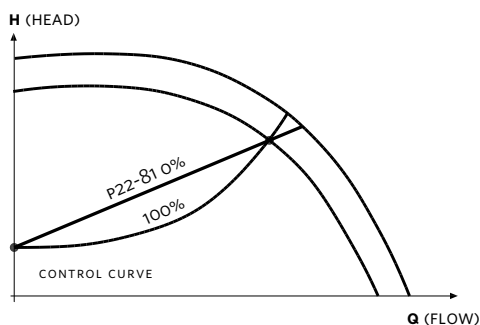

In order for the controller to determine the true fit and position of the control curve it is necessary to set some specific parameters with data relating to specific points within the operating range of the pump. There are two ways of programming the

parameters depending on whether the speed at the design duty is known or unknown.

Speed at Required System Design Point is known (Refer to FIG. 11):

- 1 Set the design head, H_{DESIGN} , value in par. 20-21 (Setpoint 1), after setting unit of head in par. 20-12 (Reference/Feedback unit)
- 2 Set the speed of the pump at design head, H_{DESIGN} , and design flow using par. 22-86 (Speed at Design Point [Hz])
- 3 Set the minimum head required, H_{MIN} , using par. 22-87 (Pressure at No-Flow Speed).
- 4 Adjust the shape of the control curve if required using par. 22-81 as shown in figure 12.

13.2 CONSTANT PRESSURE CONTROL

Design Envelope pumps can be configured to maintain a constant pump head in a system as the demand varies. This effectively simulates the mounting of a differential pressure sensor at, or near, the pump.

13.2.1 SETTINGS FOR CONSTANT PRESSURE CONTROL

- 1 To revert to this mode of control simply follow these steps: Set the design head, H_{DESIGN} , value in par. 20-21 (Setpoint 1). In the units set in par.20-12 (Reference/feedback unit.)
- 2 Turn off flow compensation by setting par. 22-80 to 'Disabled' [o]

13.3 CHANGING CONTROL MODES

13.3.1 CHANGE TO EXTERNAL SENSOR CONTROL

- 1 Change parameter 0-10 from 1 to 2
- 2 Connect the sensor to terminals 54 (+) and 55 (-)
- 3 Move switch s202 (beside terminal input 54) to ON if the speed command is 4-20mA, or leave it OFF if it's 0-10Vdc
- 4 If the sensor signal is neither 0-10Vdc nor 4-20mA, enter the correct voltage or input range in parameters 6-10 to 6-13
- 5 Enter the sensor and setpoint data in the parameters listed below

PARAM.	NAME	SETUP 2 (EXTERNAL SENSOR)	
0-10	Active set-up	2	
6-24	Terminal 54 low ref./feedback value	Minimum sensor value	
6-25	Terminal 54 high Ref./feedback value	Maximum sensor value	
20-02	Feedback 1 source unit	Unit of external sensor	
20-12	Reference/feed-back unit	Unit of external sensor	
20-13	Minimum reference/feedback	Low limit of sensor	
20-14	Maximum reference/feedback	Upper limit of sensor	
20-21	Setpoint 1	Design setpoint	
20-93	PID proportional gain	Needs to be fine tuned on site	Start at 2
20-94	PID Integral Time	Needs to be fine tuned on site	Start at 1
22-43	Wake Up Speed [Hz]	Need to be fine tuned on site	Start at 20

13.3.2 CHANGE TO OPEN LOOP (BAS) CONTROL

- 1 Change parameter 0-10 from 1 to 3
- 2 Connect the BAS command on terminals 53 (+) and 55 (-)
- 3 Move switch s201 (beside terminal input 53) to ON if the speed command is 4-20mA, or leave it OFF if it's 0-10Vdc
- 4 If the reference signal is neither 0-10Vdc nor 4-20mA, enter the correct voltage or input range in parameters 6-10 to 6-13
- 5 The maximum speed (at 20mA or 10Vdc) can be adjusted in parameter 3-03
- 6 The drive ON/OFF status can be read as a dry contact between terminals 05 and 06
- 7 The drive alarm status can be read as a dry contact between terminals 01 and 02
- 8 Terminals 42(+) and 39(-) can provide a 0/4-20mA output which by default is disabled, but can be configured to provide speed feedback or sensorless flow

13.3.3 CHANGE TO SENSORLESS CONTROL

- 1 Change parameter 0-10 to 1
The unit will start controlling based on the pump design data
- 2 If the pump operation point needs to be changed, see the parameters that need to be modified in Section 6.1 Sensorless

14.0 WARNINGS AND ALARMS

A warning or an alarm is signalled by the relevant led on the front of the inverter and indicated by a code on the display. A warning remains active until its cause is no longer present. Under certain circumstances operation of the pump may still be continued. Warning messages may be critical, but are not necessarily so.

In the event of an alarm, the inverter will have tripped. Alarms must be reset to restart operation once their cause has been rectified. In many cases the auto reset function will restart the pump. Alternatively, the **Reset** button on the control panel can be pressed.



After a manual reset using the **Reset** button on the control panel, the **Auto On** button must be pressed to restart the pump.

If an alarm cannot be reset, the reason may be that its cause has not been rectified, or the alarm is trip-locked (see also table on following page).

Alarms that are trip-locked offer additional protection, means that the mains supply must be switched off before the alarm can be reset. After being switched back on, the inverter is no longer blocked and may be reset as described above once the cause has been rectified.

Alarms that are not trip-locked can also be reset using the automatic reset function in par. 14-20 Reset Mode (Warning: automatic wake-up is possible!) If a warning and alarm is marked against a code in the table on the following page, this means that either a warning occurs before an alarm, or it can be specified whether it is a warning or an alarm that is to be displayed for a given fault. This is possible, for instance, in par. 1-90 Motor Thermal Protection. After an alarm or trip, the motor carries on coasting, and the alarm and warning flash on the inverter. Once the problem has been rectified, only the alarm continues flashing.

14.1 FAULT MESSAGES

WARNING 1, 10 Volts low:

The 10 v voltage from terminal 50 on the control card is below 10 v. Remove some of the load from terminal 50, as the 10 v supply is over-loaded. Max. 15 mA or minimum 590 Ω.

WARNING/ALARM 2, Live zero error:

The signal on terminal 53 or 54 is less than 50% of the value set in par.6-10 Terminal 53 Low Voltage, par. 6-12 Terminal 53 Low Current, par.6-20 Terminal 54 Low Voltage, or par. 6-22 Terminal 54 Low Current respectively.

WARNING/ALARM 3, No motor:

No motor has been connected to the output of the inverter.

WARNING/ALARM 4, Mains phase loss:

A phase is missing on the supply side, or the mains voltage imbalance is too high. This message also appears in case of a fault in the input rectifier on the inverter. Check the supply voltage and supply currents to the inverter.

WARNING 5, DC link voltage high:

The intermediate circuit voltage (DC) is higher than the over-voltage limit of the control system. The inverter is still active.

WARNING 6, DC link voltage low:

The intermediate circuit voltage (DC) is below the under voltage limit of the control system. The inverter is still active.

WARNING/ALARM 7, DC over voltage:

If the intermediate circuit voltage exceeds the limit, the inverter trips after a time.

WARNING/ALARM 8, DC under voltage:

If the intermediate circuit voltage (DC) drops below the "voltage warning low" limit, the inverter checks if 24 v back-up supply is connected. If no 24 v backup supply is connected, the inverter trips after a given time depending on the unit.

WARNING/ALARM 9, Inverter overloaded:

The inverter is about to cut out because of an overload (too high current for too long). The counter for electronic, thermal inverter protection gives a warning at 98% and trips at 100%, while giving an alarm. You cannot reset the inverter until the counter is below 90%. The fault is that the inverter is overloaded by more than nominal

WARNING/ALARM 10, Motor ETR over temperature:

According to the electronic thermal protection (ETR), the motor is too hot. You can choose if you want the inverter to give a warning or an alarm when the counter reaches 100% in par. 1-90 Motor Thermal Protection. The fault is that the motor is overloaded by more than nominal current for too long. Check that the motor par. 1-24 Motor Current is set correctly.

WARNING/ALARM 11, Motor thermistor over temp:

The thermistor or the thermistor connection is disconnected. You can choose if you want the inverter to give a warning or an alarm in par. 1-90 Motor Thermal Protection. Check that the thermistor is connected correctly between terminal 53 or 54 (analog voltage input) and terminal 50 (+ 10 Volts supply), or between terminal 18 or 19 (digital input pnp only) and terminal 50. If a kty sensor is used, check for correct connection between terminal 54 and 55.

WARNING/ALARM 12, Torque limit:

The torque is higher than the value in par. 4-16 Torque Limit Motor Mode (in motor operation) or the torque is higher than the value in par.4-17 Torque Limit Generator Mode (in regenerative operation).

WARNING/ALARM 13, Over Current:

The inverter peak current limit (approx. 200% of the rated current) is exceeded. The warning will last approx. 8-12 sec., then the inverter trips and issues an alarm. Turn off the inverter and check if the motor shaft can be turned and if the motor size matches the inverter.

ALARM 14, Earth fault:

There is a discharge from the output phases to earth, either in the cable between the inverter and the motor or in the motor itself. Turn off the inverter and remove the earth fault.

ALARM 15, In-complete hardware:

A fitted option is not handled by the present control board (hardware or software).

ALARM 16, Short-circuit:

There is short-circuiting in the motor or on the motor terminals. Turn off the inverter and remove the short-circuit.

WARNING/ALARM 17, Control word timeout:

There is no communication to the inverter. The warning will only be active when par. 8-04 Control Timeout Function is **not** set to off. If par. 8-04 Control Timeout Function is set to Stop and Trip, a warning appears and the inverter ramps down to zero speed, while giving an alarm. par. 8-03 Control Timeout Time could possibly be increased.

WARNING 22, Hoist Mech. Brake:

Report value will show what kind it is. 0 = The torque ref. was not reached before timeout1 = There was no brake feedback before timeout.

WARNING 23, Internal fans:

External fans have failed due to defect hardware or fans not mounted.

WARNING 24, External fan fault:

The fan warning function is an extra protection function that checks if the fan is running / mounted. The fan warning can be disabled in par.14-53 Fan Monitor, [0] Disabled.

WARNING 25, Brake resistor short-circuited:

The brake resistor is monitored during operation. If it short-circuits, the brake function is disconnected and the warning appears. The inverter still works, but without the brake function. Turn off the inverter and replace the brake resistor (see par. 2-15 Brake Check).

ALARM/WARNING 26, Brake resistor power limit:

The power transmitted to the brake resistor is calculated as a percentage, as a mean value over the last 120 s, on the basis of the resistance value of the brake resistor (par. 2-11 Brake Resistor (OHM)) and the intermediate circuit voltage. The warning is active when the dissipated braking power is higher than 90%. If Trip [2] has been selected in par. 2-13 Brake Power Monitoring, the inverter cuts out and issues this alarm, when the dissipated braking power is higher than 100%.

WARNING/ALARM 27, Brake chopper fault:

The brake transistor is monitored during operation and if it short-circuits, the brake function disconnects and the warning comes up. The inverter is still able to run, but since the brake transistor has short-circuited, substantial power is transmitted to the brake resistor, even if it is inactive. Turn off the inverter and remove the brake resistor. Warning: There is a risk of substantial power being transmitted to the brake resistor if the brake transistor is short-circuited.

ALARM/WARNING 28, Brake check failed:

Brake resistor fault: the brake resistor is not connected/working.

WARNING/ALARM 29, Drive over temperature:

If the enclosure ISIP00, IP20/NEMA1 or IP21/type 1, the cut-out temperature of the heat-sink is 203°F +9°F (95°C +5°C). The temperature fault cannot be reset, until the temperature of the heatsink is below 158°F (70°C). The fault could be: -Ambient temperature too high; -Too long motor cable

ALARM 30, Motor phase U missing:

Motor phase U between the frequency converter and the motor is missing. Turn off the frequency converter and check motor phase U.

ALARM 31, Motor phase V missing:

Motor phase V between the inverter and the motor is missing. Turn off the inverter and check motor phase V.

ALARM 32, Motor phase W missing:

Motor phase W between the inverter and the motor is missing. Turn off the frequency converter and check motor phase W.

ALARM 33, Inrush fault:

Too many power ups have occurred within a short time period.

WARNING/ALARM 34, Fieldbus communication fault:

The fieldbus on the communication option card is not working.

WARNING/ALARM 36, Mains failure:

This warning/alarm is only active if the supply voltage to the inverter is lost and par. 14-10 Mains Failure is **not** set to off. Possible correction: check the fuses to the frequency converter

WARNING/ALARM 37, Phase Imbalance:

There is a current imbalance between the power units.

ALARM 38, Internal fault:

Contact your local Armstrong supplier.

ALARM 39, Heatsink Sensor:

No feedback from the heatsink sensor.

WARNING 40, Overload of Digital Output Terminal 27:

Check the load connected to terminal 27 or remove short-circuit connection. Check par. 5-00 Digital I/O Mode and par. 5-01 Terminal 27 Mode.

WARNING 41, Overload of Digital Output Terminal 29:

Check the load connected to terminal 29 or remove short-circuit connection. Check par. 5-00 Digital I/O Mode and par. 5-02 Terminal 29 Mode.

WARNING 42, Overload of Digital Output On x30/6 :

Check the load connected to x30/6 or remove short-circuit connection. Check par. 5-32 Term X30/6 Digi Out (MCB 101).

WARNING 42, Overload of Digital Output On x30/7 :

Check the load connected to x30/7 or remove short-circuit connection. Check par. 5-33 Term x30/7 Digi Out (MCB 101).

ALARM 46, Pwr. card supply:

The supply on the power card is out of range.

WARNING 47, 24 v supply low:

The external 24 v dc backup power supply may be overloaded, otherwise contact your Armstrong supplier.

ALARM 48, 1.8 v supply low:

Contact your Armstrong supplier.

WARNING 49, Speed limit:

The speed has been limited by range in par. 4-11 Motor Speed Low Limit [RPM] and par. 4-13 Motor Speed High Limit [rpm].

ALARM 50, AMA calibration failed:

Contact your Armstrong supplier.

ALARM 51, AMA check Unom and Inom:

The setting of motor voltage, motor current, and motor power is presumably wrong. Check the settings.

ALARM 52, AMA low Inom:

The motor current is too low. Check the settings.

ALARM 53, AMA motor too big:

The motor is too big for the ama to be carried out.

ALARM 54, AMA motor too small:

The motor is too small for the ama to be carried out.

ALARM 55, AMA par. out of range:

The par. values found from the motor are outside acceptable range.

ALARM 56, AMA interrupted by user:

The ama has been interrupted by the user.

ALARM 57, AMA timeout:

Try to start the ama again a number of times, until the ama is carried out. Please note that repeated runs may heat the motor to a level where the resistance r_s and r_r are increased. In most cases, however, this is not critical.

WARNING/ALARM 58, AMA internal fault:

Contact your Armstrong supplier.

WARNING 59, Current limit:

The current is higher than the value in par. 4-18 Current Limit.

WARNING 60, External Interlock:

External Interlock has been activated. To resume normal operation, apply 24 v dc to the terminal programmed for External Interlock and reset the inverter (via Bus, Digital I/O or by pressing **Reset**).

WARNING/ALARM 61, Tracking Error:

Tracking error. Contact your supplier.

WARNING 62, Output Frequency at Maximum Limit:

The output frequency is limited by the value set in par. 4-19 Max Output Frequency

WARNING 64, Voltage Limit:

The load and speed combination demands a motor voltage higher than the actual dc link voltage.

WARNING/ALARM/TRIP 65, Control Card Over Temperature:

Control card over temperature: The cut-out temperature of the control card is 176°F (80°C).

WARNING 66, Heatsink Temperature Low:

The heat sink temperature is measured as 32°F (0°C). This could indicate that the temperature sensor is defective and thus the fan speed is increased to the maximum in case the power part or control card is very hot. If the temperature is below 59°F (15°C) the warning will be present.

ALARM 67, Option Configuration has Changed:

One or more options has either been added or removed since the last power-down.

ALARM 68, Safe Stop:

Safe Stop has been activated. To resume normal operation, apply 24 vdc to terminal 37 then send a Reset signal (via Bus, Digital I/O or by pressing **Reset**).

ALARM 69, Pwr. Card Temp:

Power card over temperature.

ALARM 70, Illegal Frequency Converter Configuration:

Actual combination of control board and power board is illegal.

ALARM 90, Feedback Mon.:

ALARM 91, Analogue Input 54 Wrong Settings:

Switch s202 has to be set in position off (voltage input), when a kty sensor is connected to the analogue input terminal 54.

ALARM 92, No Flow:

A no load situation has been detected for the system. See parameter group 22-2*.

ALARM 93, Dry Pump:

A no flow situation and high speed indicates that the pump has run dry. See parameter group 22-2*.

ALARM 94, End of Curve:

Feed back stays lower than the set point, which may be indicates a leak-age in the pipe system. See parameter group 22-5*.

ALARM 95, Broken Belt:

Torque is below the torque level set for no load indicating a broken belt. See parameter group 22-6*.

ALARM 96, Start Delayed:

Start of the motor has been delayed due to short cycle protection is active. See parameter group 22-7*.

ALARM 250, New Spare Part:

The power or Switch Mode Power Supply has been exchanged. The inverter type code must be restored in the eeprom. Select the correct type code in par. 14-23 Type code Setting according to the label on unit. Remember to select 'Save to eeprom' to complete.

ALARM 251, New Type Code:

The frequency converter has got a new type code.

15.0 ACOUSTIC NOISE AND VIBRATION

If the pump or the pipework close to the pump is making noise or vibrations at certain frequencies, try the following:

- Speed Bypass, parameters 4-6*
- Over-modulation, parameter 14-03 set to off
- Switching pattern and frequency parameters 14-0*
- Resonance Dampening, parameter 1-64

TABLE 1 Alarm/warning code list

NO.	DESCRIPTION	WARNING	ALARM /TRIP	ALARM /TRIP LOCK	PARAMETER REFERENCE
1	10 volts low	x			
2	Live zero error	(x)	(x)		Par. 6-01 Live zero time-out function
3	No motor	(x)			Par. 1-80 Function at Stop
4	Mains phase loss	(x)	(x)	(x)	Par. 14-12 Function at mains imbalance
5	dc link voltage high	x			
6	dc link voltage low	x			
7	dc over voltage	x	x		
8	dc under voltage	x	x		
9	Inverter overloaded	x	x		
10	Motor ETR over temperature	(x)	(x)		Par. 1-90 Motor thermal protection
11	Motor thermistor over temperature	(x)	(x)		Par. 1-90 Motor thermal protection
12	Torque limit	x	x		
13	Over current	x	x	x	
14	Earth fault	x	x	x	
15	Incomp. HW		x	x	
16	Short circuit		x	x	
17	Control word timeout	(x)	(x)		Par. 8-04 Control time-out function
23	Internal fans				
24	External fans				
25	Brake resistor short circuited	x			
26	Brake resistor power limit	(x)	(x)		Par. 2-13 Brake power monitoring
27	Brake chopper short circuited	x	x		
28	Brake check	(x)	(x)		Par. 2-15 Brake check
29	Power board over temp	x	x	x	
30	Motor phase U missing	(x)	(x)	(x)	Par. 4-58 Missing motor phase function
31	Motor phase V missing	(x)	(x)	(x)	Par. 4-58 Missing motor phase function
32	Motor phase W missing	(x)	(x)	(x)	Par. 4-58 Missing motor phase function
33	Inrush fault		x	x	
34	Fieldbus communication fault	x	x		
36	Mains failure				
38	Internal fault		x	x	

NO.	DESCRIPTION	WARNING	ALARM /TRIP	ALARM /TRIP LOCK	PARAMETER REFERENCE
40	Overload T27				
41	Overload T29				
42	Overload x30/6-7				
47	24v supply low	x	x	x	
48	1.8v supply low		x	x	
49	Speed limit				
50	AMA calibration failed		x		
51	AMA check U_{nom} and I_{nom}		x		
52	AMA low I_{nom}		x		
53	AMA motor too big		x		
54	AMA motor too small		x		
55	AMA parameter out of range		x		
56	AMA interrupted by user		x		
57	AMA timeout		x		
58	AMA internal fault	x	x		
59	Current limit	x			
60	External interlock				
62	Output frequency at maximum limit	x			
64	Voltage limit	x			
65	Control board-over temperature	x	x	x	
66	Heat sink temperature low	x			
67	Option configuration has changed		x		
68	Safe stop activated		x		
70	Illegal Fc configuration				
80	Drive initialized to Default Value		x		
92	No-flow	x	x		Par. 22-2*
93	Dry pump	x	x		Par. 22-2*
94	End of curve	x	x		Par. 22-5*
95	Broken belt	x	x		Par. 22-6*
96	Start delayed	x			Par. 22-7*
97	Stop delayed	x			Par. 22-7*
98	Clock fault	x			Par. 0-7*

TABLE 2 IVS 102 parameter settings

	PAR.	NAME	SETUP 1 (SENSORLESS)	SETUP 2 (EXTERNAL SENSOR)	SETUP 3 (EXTERNAL BMS)
OPERATION/ DISPLAY	0-20	Display line 1.1 Small	Reference [unit]	Reference [unit]	Reference [%]
	0-21	Display line 1.2 Small	Frequency	Frequency	Frequency
	0-22	Display line 1.3 Small	Power (kW or hp depending on site)	Power (kW or hp depending on site)	Power (kW or hp depending on site)
	0-23	Display line 2 large	Feedback 1 [unit]	Feedback 1 [unit]	Feedback 1 [unit]
	0-24	Display line 3 large	Sensorless Readout	Sensorless Readout	No Function
LOAD AND MOTOR	1-00	Configuration mode	Closed Loop	Closed Loop	Open Loop
	1-03	Torque characteristics	Variable Torque	Variable Torque	Variable Torque
	1-20	Motor power [kW]	Motor nameplate power	Motor nameplate power	Motor nameplate power
	1-22	Motor voltage	Motor nameplate Volts	Motor nameplate Volts	Motor nameplate Volts
	1-23	Motor frequency	60 or 50 per nameplate	60 or 50 per nameplate	60 or 50 per nameplate
	1-24	Motor current	FLA per nameplate	FLA per nameplate	FLA per nameplate
	1-25	Motor nominal speed [rpm]	Motor nameplate speed	Motor nameplate speed	Motor nameplate speed
1-73	Flying start	Enabled	Enabled	Enabled	
BRAKES	2-17	Over-voltage control	Enabled	Enabled	Enabled
REFERENCE/ RAMPS	3-02	Minimum reference	0	No operation	0
	3-03	Maximum reference	Hdesign [in unit of mapped perf data]	No operation	Max frequency of app (50 or 60Hz)
	3-15	Reference 1 source	No operation	No operation	Analog input 53
	3-16	Reference 2 source	No operation	No operation	No operation
	3-17	Reference 3 source	No operation	No operation	No operation
	3-41	Ramp up time	Desired ramp time (60s typical)	Desired ramp time (60s typical)	Desired ramp time (60s typical)
3-42	Ramp down time	Desired ramp time (60s typical)	Desired ramp time (60s typical)	Desired ramp time (60s typical)	
LIMITS/ WARNINGS	4-10	Motor speed direction	Clockwise	Clockwise	Clockwise
	4-11	Motor speed low limit [rpm]			
	4-12	Motor speed low limit [hz]	Min frequency of application	Min frequency of application	Min frequency of application
	4-14	Motor speed high limit [hz]	Max frequency of application	Max frequency of application	Max frequency of application
DIGITAL IN/OUT	5-01	Terminal 27 mode	Input	Input	Input
	5-10	Terminal 18 digital input	Start	Start	Start
	5-11	Terminal 19 digital input	No operation	No operation	No operation
	5-12	Terminal 27 digital input	Run Permissive	Run Permissive	Run Permissive
	5-13	Terminal 29 digital input	Jog	Jog	Jog
	5-14	Terminal 32 digital input	No operation	No operation	No operation
	5-15	Terminal 33 digital input	No operation	No operation	No operation
	5-16	Terminal x30/2 digital input	No operation	No operation	No operation
	5-17	Terminal x30/3 digital input	No operation	No operation	No operation
	5-18	Terminal x30/4 digital input	No operation	No operation	No operation
	5-40	Function relay 1	No operation	No operation	Alarm
5-40	Function relay 2	No operation	No operation	Running	

	PAR.	NAME	SETUP 1 (SENSORLESS)	SETUP 2 (EXTERNAL SENSOR)	SETUP 3 (EXTERNAL BMS)
ANALOG IN/OUT	6-00	Live zero timeout time	No operation	1s	No operation
	6-01	Live zero timeout function	No operation	Stop	No operation
	6-10	Terminal 53 low voltage	No operation	No operation	0.07
	6-11	Terminal 53 high voltage	No operation	No operation	10
	6-12	Terminal 53 low current	No operation	No operation	4
	6-13	Terminal 53 high current	No operation	No operation	20
	6-14	Terminal 53 low ref./feedb. value	No operation	No operation	0
	6-15	Terminal 53 high ref./feedb. value	No operation	No operation	50
	6-20	Terminal 54 low voltage	No operation	0.07	No operation
	6-21	Terminal 54 high voltage	No operation	10	No operation
	6-22	Terminal 54 low current	No operation	4	No operation
	6-23	Terminal 54 high current	No operation	20	No operation
	6-24	Terminal 54 low ref./feedb. value	No operation	minimum sensor value	0
	6-25	Terminal 54 high ref./feedb. value	No operation	maximum sensor value	50
	6-50	Terminal 42 output	No operation	No operation	No operation
COMM. AND OPTION	8-30	Protocol	FC, MC	Depends on controller	Depends on controller
	8-31	Address	1	Depends on controller	Depends on controller
	8-32	Baud rate	9600	Depends on controller	Depends on controller
	8-33	Parity/stop bits	Even Prity, 1 Stop bit	Depends on controller	Depends on controller
SPECIAL FUNCTIONS	14-10	Mains failure	[0] No function	[0] No function	[0] No function
	14-11	Main voltage at mains fault	Set to 83.5% of site voltage	Set to 83.5% of site voltage	Set to 83.5% of site voltage
	14-12	Function at mains imbalance	[0] No function	[0] No function	[0] No function
	14-60	Function at over temperature	[1] Derate	[1] Derate	[1] Derate
	14-61	Function at inverter overload	[1] Derate	[1] Derate	[1] Derate
	14-62	Inverter overload derate current (%)	95	95	95
DRIVE CLOSED LOOP	20-00	Feedback 1 source	Sensorless Pressure	Analog input 54	No operation
	20-02	Feedback 1 source unit	Unit used for feedback 1 source	Unit of external sensor	No operation
	20-12	Reference/feedback unit	Unit of par 2021 (ex: ft WG)	Unit of external sensor	No operation
	20-13	Minimum reference/feedback		Low limit of sensor	No operation
	20-14	Maximum reference/feedback	Max of head and flow mapped	Upper limit of sensor	No operation
	20-20	Feedback function	Minimum	Minimum	No operation
	20-21	Setpoint 1	Design Head in unit in par 2012	Design setpoint	No operation
	20-60	Sensorless unit	Unit of par1850 (ex: GPM)	not used	No operation
	20-70	Closed-loop type	not used	Fast Pressure	No operation
	20-71	pid performance	not used	Normal	No operation
	20-93	pid proportional gain	Start at 0.05	Needs to be fine tuned on site	No operation
20-94	pid integral time	Start at 0.1	Needs to be fine tuned on site	No operation	
APPLICATION FUNCTIONS	22-43	Wake up speed [hz]	No operation	Needs to be fine tuned on site	No operation
	22-50	End of curve function	Off	Off	Off
	22-80	Flow compensation	Enabled	No operation	Disabled
	22-81	Square-linear curve approximation	100%	No operation	100%
	22-84	Speed at no-flow [hz]	No operation	Frequency at no flow and minimum head set	No operation
	22-86	Speed at design point [hz]	No operation	No operation	No operation
	22-87	Pressure at no-flow speed	40% of maximum system head	No operation	No operation
	22-89	Flow at design point	Flow at Design Point	No operation	No operation

TORONTO

23 BERTRAND AVENUE,
TORONTO, ONTARIO,
CANADA, M1L 2P3
+1 416 755 2291

BUFFALO

93 EAST AVENUE, NORTH
TONAWANDA, NEW YORK,
USA, 14120-6594
+1 716 693 8813

DROITWICH SPA

POINTON WAY, STONEBRIDGE CROSS
BUSINESS PARK, DROITWICH SPA,
WORCESTERSHIRE,
UNITED KINGDOM, WR9 0LW
+44 121 550 5333

MANCHESTER

WOLVERTON STREET, MANCHESTER
UNITED KINGDOM, M11 2ET
+44 161 223 2223

BANGALORE

#18, LEWIS WORKSPACE, 3RD FLOOR,
OFF MILLERS - NANDIDURGA ROAD,
JAYAMAHAL CBD, BENSON TOWN,
BANGALORE, INDIA 560 046
+91 80 4906 3555

SHANGHAI

UNIT 903, 888 NORTH SICHUAN RD.
HONGKOU DISTRICT, SHANGHAI
CHINA, 200085
+86 21 5237 0909

BEIJING

ROOM 1612, NANYIN BUILDING NO.2
NORTH EAST THRID RING ROAD
CHAOYANG DISTRICT, BEIJING,
CHINA 100027
+86 21 5237 0909

SÃO PAULO

RUA JOSÉ SEMIÃO RODRIGUES
AGOSTINHO, 1370 GALPÃO 6 EMBU
DAS ARTES, SAO PAULO, BRAZIL
+55 11 4785 1330

LYON

93 RUE DE LA VILLETTE
LYON, 69003 FRANCE
+33 4 26 83 78 74

DUBAI

JAFZA VIEW 19, OFFICE 402
P.O. BOX 18226 JAFZA,
DUBAI - UNITED ARAB EMIRATES
+971 4 887 6775

JIMBOLIA

STR CALEA MOTILOR NR. 2C
JIMBOLIA 305400, JUD.TIMIS
ROMANIA
+40 256 360 030

FRANKFURT

WESTERBACHSTRASSE 32,
D-61476 KRONBERG IM TAUNUS
GERMANY
+49 6173 999 77 55

ARMSTRONG FLUID TECHNOLOGY®
ESTABLISHED 1934

ARMSTRONGFLUIDTECHNOLOGY.COM