

INSTALLATION AND OPERATING INSTRUCTIONS

**HORIZONTAL SPLIT CASE FIRE PUMPS
INSTALLATION AND OPERATING MANUAL**

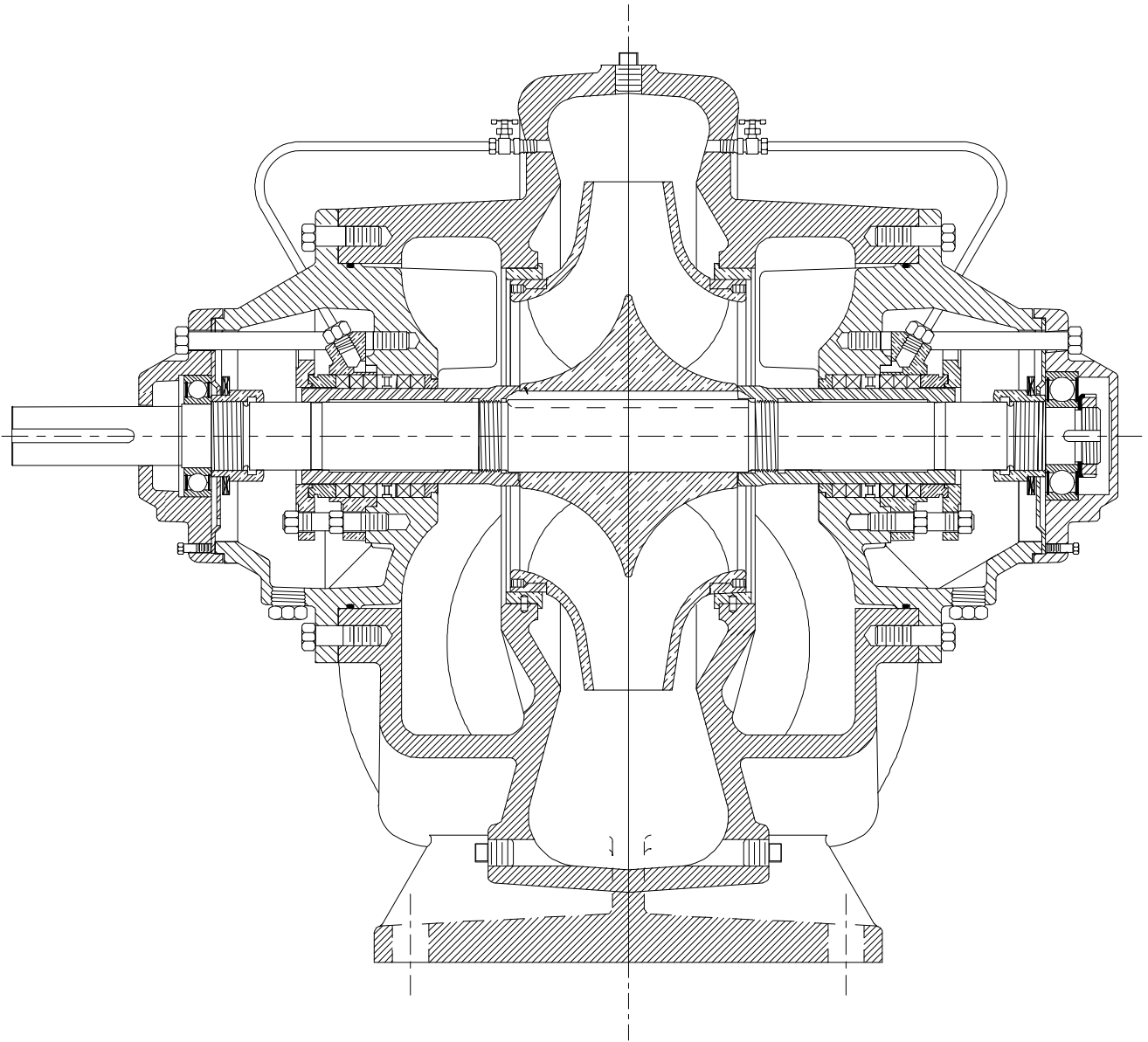

INSTALLATION AND OPERATING MANUAL HORIZONTAL SPLIT CASE FIRE PUMPS

The Armstrong's innovative Series 4600 HSC pump is designed to allow easy maintenance. The pumps same level suction and discharge permits easy-piping layout and pump installation. Design features, such as bearing removal with no special tools, will make the reliable HSC pump a trouble-free pump for many years.

Armstrong series 4600 HSC pumps are thoroughly tested and inspected before shipment, but should be carefully examined for possible damage during transit. Contact your Armstrong Darling representative and the Transport Company immediately if there is any evidence of mishandling.

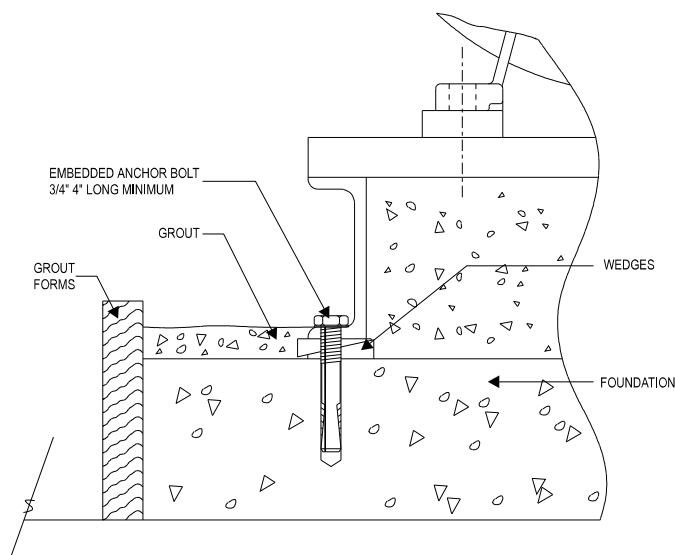

INSTALLATION

1. LOCATION AND STORAGE

- Locate the unit in a dry place as near the city water entrance as practical with a short, direct suction pipe
- Shaft should be rotated by hand 10 to 15 revolutions every one to three months depending on storage conditions

2. FOUNDATION FOR HSC PUMP

- Foundation should be sufficiently substantial to absorb any vibration and to form a permanent, rigid support for the base plate
- Foundation bolts of suitable size should be embedded in the concrete located by a drawing or template
- Place pumping unit on foundation with wedges under base plate leaving approximately 3/4" space for grouting
- Carefully level the unit by adjusting the wedges until shafts of pump and driver are leveled, recreating factory alignment
- Check coupling faces as well as suction and discharge flanges of pump for horizontal or vertical position with a level
- Slight misalignment at this point may be corrected by adjusting the wedges

After unit has been in operation for about a week, check alignment. Any misalignment may be corrected by placing shims between base and driver or pump feet

- **Install foundation bolts**
- **Install grout forms**
- **Fill in base with grouting**

3. PUMP MOUNTING AND PIPING

- Never connect a pump to piping, always start piping from pump
- Use as few bends as possible and preferably long radius piping
- Install good supports under suction and discharge piping with anchors near but independent of the pump
- Make sure piping exerts no strain on pump as this would throw the unit out of alignment or distort the casing
- Increase the size of both suction and discharge pipes at pump nozzle to suit pump capacity and particular conditions of installation
- Use eccentric reducers on suction
- Lay out the suction line with a continual rise towards the pump without high points, thus eliminating possibility of air pockets
- Test suction line for air leaks before starting; this becomes essential with long suction line or high static lift
- Install, at pump suction, a straight pipe of a length equivalent to 4 or 6 times its diameter
- Install gate valve close to pump in both suction and discharge lines on flooded suction application; this is used mainly to isolate the pump for inspection or repair
- Install a check valve in discharge line between pump and gate valve

CAUTION: Discharge valve only must be used to reduce the flow or shutoff the pump

PRESSURE SENSING LINE CONNECTION FOR FIRE PUMP CONTROLLERS

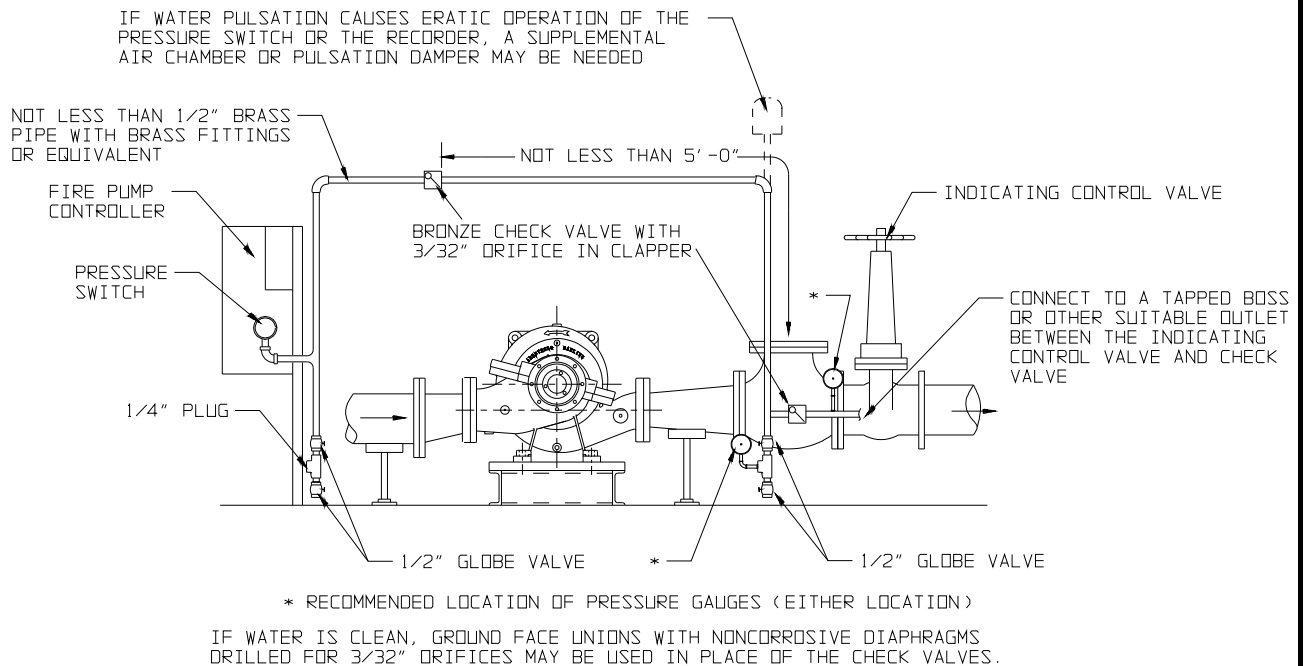

Ref.: NFPA Pamphlet 20, Fig. A-7-5.2.1

4. ALIGNMENT

The flexible coupling compensates for temperature changes and permits shafts end movement without interference; it will not compensate for misalignment. Faulty alignment will result in noisy pump operation, reduced bearing life, excessive coupling wear.

- Carefully verify the alignment after the foundation bolts have been properly tightened
- Alignment should be again verified after piping is installed and unit has operated under normal conditions at operating temperature
- To verify alignment, place a straight edge across the coupling as shown; this must rest evenly on both rims at top, bottom and both sides
- With a pair of inside calipers or thickness gauge, check distance between coupling halves at points where straight edge was used; distance must be equal at all points

5. MINIMUM FITTINGS

If minimum fittings recommended by N.F.P.A. 20 are supplied loose, they should be installed as follows:

CIRCULATION RELIEF VALVE (not supplied with diesel driven pumps)

- Install Circulation Relief Valve at the casing discharge (always before the check valve)
- Set pressure at the minimum suction pressure plus the pump rated pressure raised to the next higher 5 lb. increment
- Circulation relief valve and stuffing box should then be piped to drain

AUTOMATIC AIR RELEASE VALVE

- Install automatic air release valve on top of pump casing to vent casing and suction piping of air and vapor before start-up.

SUCTION AND DISCHARGE GAUGES

- The following gauges are required to measure both suction and discharge pressures, and must be supplied with all fire pumps to ensure close check on pump performance:
 - a. 3 ½ " dial combination pressure and vacuum suction gauge
 - b. 3 ½ " dial discharge pressure gauge
 - c. ¼ " cocks with lever handle

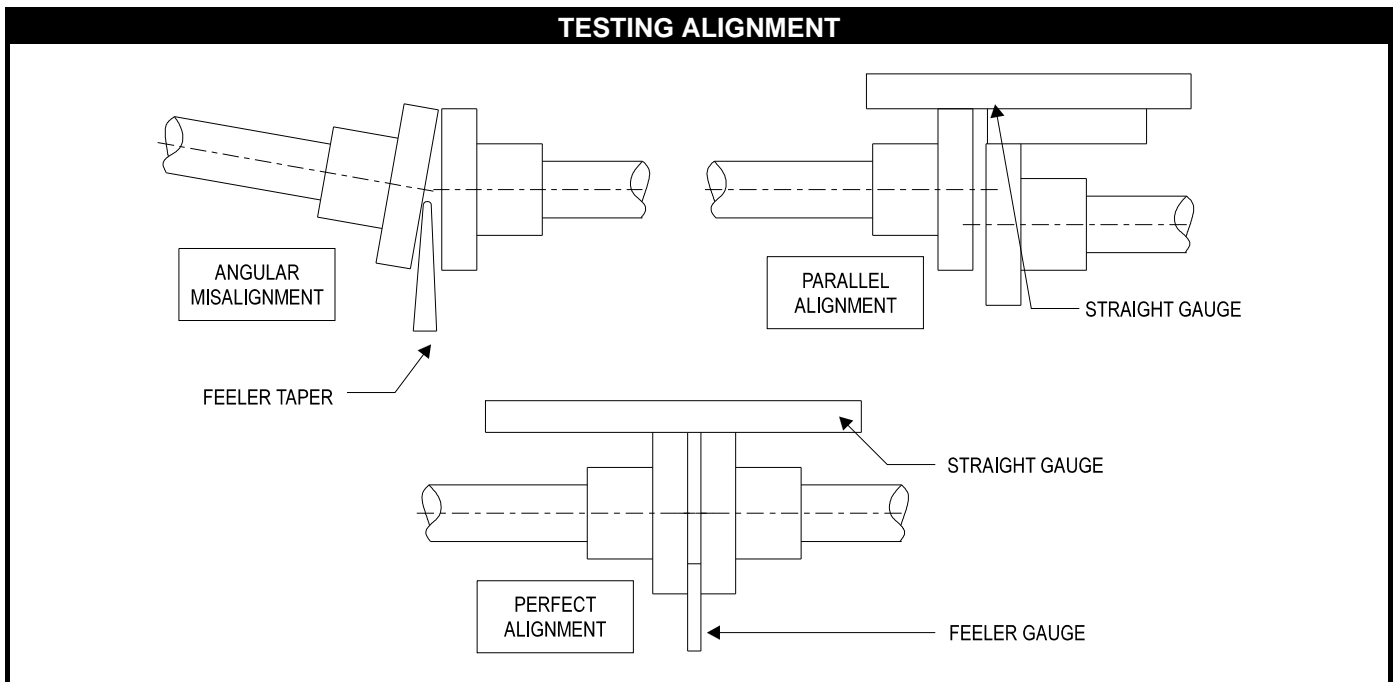

TYPICAL FIRE PUMP & CONTROLLER ARRANGEMENT HORIZONTAL SPLIT CASE - ELECTRIC DRIVEN

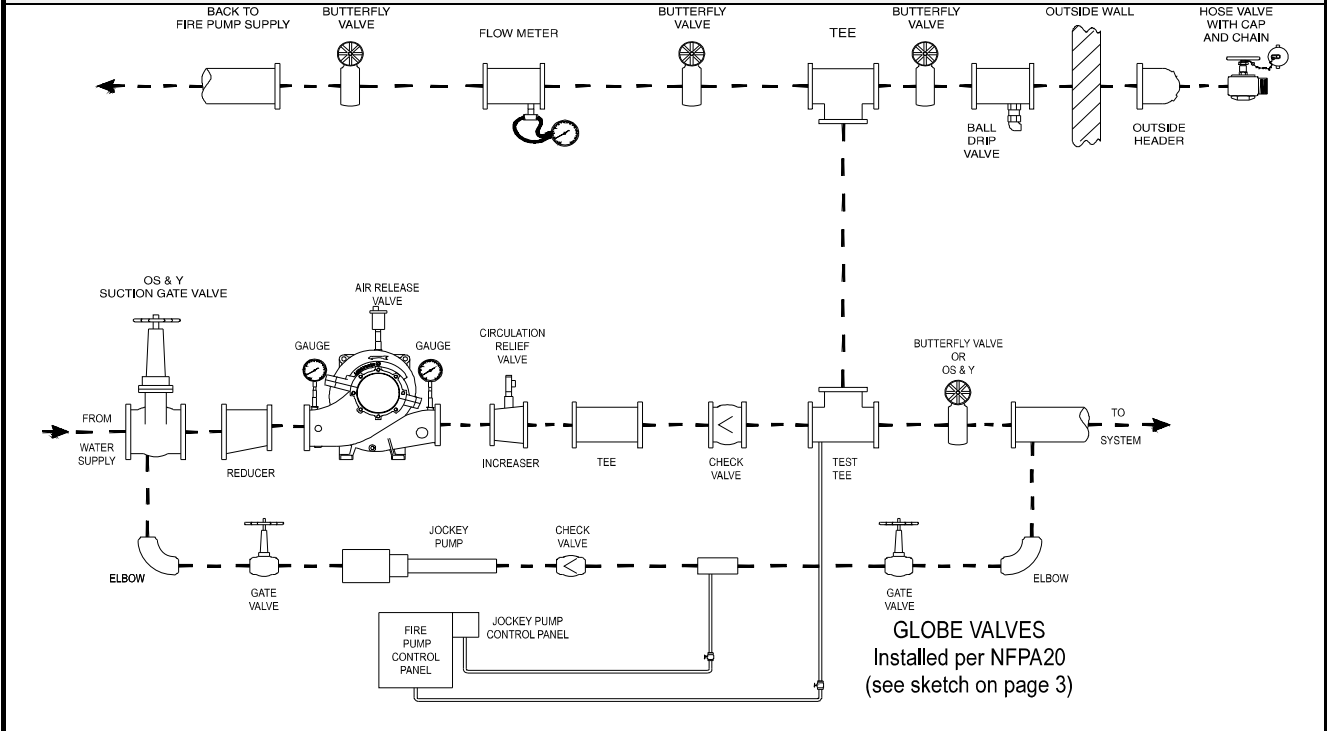

TYPICAL FIRE PUMP & CONTROLLER ARRANGEMENT HORIZONTAL SPLIT CASE - DIESEL DRIVEN

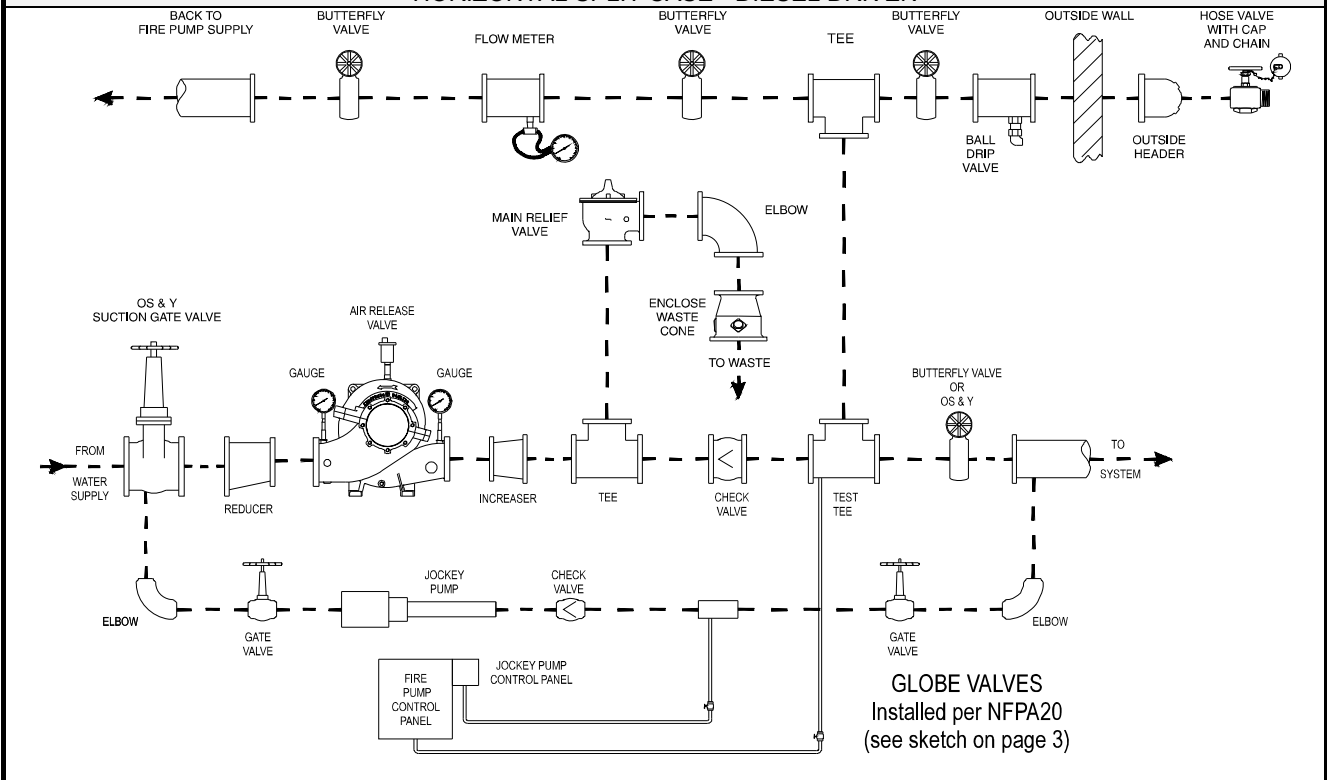

NOTE: ALL VALVES SHALL BE LISTED FOR FIRE APPLICATION These drawings are a suggested arrangement and are issued for information purposes only.

OPERATION-ELECTRIC DRIVEN

Set pressure switches to the following setting values:

◇ Fire Pump Stop Point (FSP)	⇒ FSP	= Fire Pump Shut Off Pressure + MIN. Static Suction Pressure
◇ Jockey Pump Stop Point (JSP)	⇒ JSP	= FSP
◇ Jockey Pump Start Point (JSTRT)	⇒ JSTRT	= JSP - 10 PSI
◇ Fire Pump Start Point (FSTRT)	⇒ FSTRT	= JSTRT - 5 PSI

1. PRESTART-UP

Fill out "PRESTART-UP CHECK LIST"

2. PRESSURE SWITCH SETTING

The pressure switch to start the fire pump is normally located in the lower left-hand side of fire pump controller. Similarly the pressure switch to start the Jockey pump is located in the Jockey pump controller.

Make sure that pump shutoff + MAX. suction pressure does not exceed system rated pressure or its components. If it does, a main relief valve should be installed at the pump discharge.

3. CIRCULATION RELIEF VALVE

The circulation relief valve should be set in the field at pressure to the lowest suction pressure, plus the rated pressure of the unit raised to the next higher 5 lbs increment.

4. START-UP PROCEDURE - (PUMP SEQUENCE)

CAUTION: In case of electrical control circuit problem use the emergency disconnect lever to bypass control circuits

ELECTRIC DRIVEN

- Open suction gate valves
- Check that pump is full of water and that all air contained in pump has been allowed to escape through the air release valve
- Compress packing evenly with gland (Gland nut should be finger tight)
- Lower setting of pressure switch (senses discharge pressure) to prevent pump from starting
- Place the main disconnect switch in the "ON" position
- Place circuit breaker in the "ON" position and check if "POWER ON" light is illuminated
- Check direction of driver rotation by pressing momentarily the "Start" and then "Stop" push buttons on the controller (proper direction is indicated by arrow on pump casing); for in-line pump use a light on shaft to see rotation (this is clockwise looking down from top of motor). If rotation is wrong interchange motor leads in panel per instructions in panel
- Bring the timer setting down to one (1) minute for automatic start test purpose
- Open system butterfly valve
- Bleed the system by opening a valve on the pressure sensing line to create a pressure drop
- As soon as fire pump starts check if full load current value is within the electric motor nameplate rating with service factor taken into account
- Check packing adjustment to obtain slight leak of approximately 1 drop per second
- After running for one minute (time set on the running period timer), stop pump with stop button. If you try stopping it before the time set on the timer, the pump will not stop
- Bleed again until desired start-up pressure is attained

- Allow Jockey Pump to stop automatically at pressure switch setting

START-UP PROCEDURE - (FLOW TEST PROCEDURE IF REQUIRED BY AUTHORITIES)

- Close system butterfly valve.
- Open gate valve to hose outside header for flow test or flow meter discharge valve
- Press start button to start pump
- Adjust flow by the quantity of hose valves opened or with pump discharge valve if using flow meter
- Take gauge and ammeter readings at 150% of rated flow, shutoff and other intermediate flows
- When test is finished, close gate valve

REMINDER

- Leave the disconnect switch "ON" and the circuit breaker "ON" (The "Power On" light must be lit)
- Bring timer setting back to required value one) minute for each 10HP, maximum 10 minutes

DIESEL ENGINE DRIVEN

- Open suction gate valves
- Check that pump is full of water and that all air contained in pump has been allowed to escape through the air release valve
- Compress packing evenly with gland (Gland nut should be finger tight)
- Close the Main Relief Valve using the maximum spring pressure
- Bring the timer setting down to one minute for automatic start test purpose
- Start engine manually on either battery
- Adjust Main Relief Valve (MRV) spring to allow valve to fully open
- Stop engine and open system butterfly valve
- Bleed the system by opening a valve on the pressure sensing line to create a pressure drop
- As soon as fire pump starts check engine speed and adjust to pump rated speed with throttle
- Check packing adjustment to obtain slight leak of approximately 1 drops per second
- After running for one minute (time set on the running period timer), stop pump with stop button. If you try stopping it before the time set on the timer, the pump will not stop
- Bleed again until desired start-up pressure is attained
- Allow Jockey Pump to run to stop pressure setting

START-UP PROCEDURE - (FLOW TEST PROCEDURE IF REQUIRED BY AUTHORITIES)

- Close system butterfly valve.
- Open gate valve to hose outside header for flow test or flow meter discharge valve
- Press start button to start pump
- Adjust flow by the quantity of hose valves opened or with pump discharge valve if using flow meter

- Take gauge and ammeter readings at 150% of rated flow, shutoff and other intermediate flows
- When test is finished, close gate valve

5. AUTOMATIC OPERATION

- Open system butterfly valve and turn all the isolating valves to the fully open position
- Place the main disconnect switch on the "ON" position
- Switch fire pump circuit breaker to the "ON" position
- Switch the jockey pump to "AUTO" (the "Power On" light must be lit)

NOTE

- When the operating differential of pressure switches do not permit these settings, the settings should be as close as equipment will permit
- The settings should be established by pressures observed on test gauges
- All devices are preset at the factory and should normally require no further adjustment
- A final adjustment may be made on any control to match the exact system requirements

AFTER START-UP, MAKE SURE ...

- To open system butterfly valve
- To bring minimum run timer back to 30 minutes
- Valve on pump suction must be fully open as throttling on suction side is harmful to the pump
- Pump will not run dry. Most centrifugal pumps have close clearances and cannot run dry without serious damage resulting

MAINTENANCE

HSC pumps are built to operate without periodic maintenance. A systematic inspection made at regular intervals, giving special attention to the following, will ensure years of trouble-free operation.

1. GENERAL CARE

- Keep unit clean
- Provide the motor with adequate overload protection
- Keep flying chips or other loose particles away from the ventilating openings of the motor
- Avoid operating the unit in overheated surroundings

2. BEARINGS

- SEALED GREASED FOR LIFE BEARINGS are fitted on your pump.
- No particular attention is required
- No need for greasing since the bearings are greased for the entire bearing life
- If abnormal noises come from the bearing during normal operation, replace bearings

3. STUFFING BOX WITH PACKING

STUFFING BOX DISMANTLING

- Adjust pressure of packing gland to obtain a slight leak of 6 to 8 drops per minute for suction pressures up to 20 PSIG (The increase in suction pressure causes proportional increase in leakage through the stuffing box)
- Remove flush line connection from stuffing box extension
- Remove gland plate from stuffing box
- Remove stuffing box extension

PACKING REPLACEMENT

- When removing old packing, make sure bottom rings are completely removed
- Clean thoroughly the stuffing box and check condition of shaft sleeve (A badly worn or corroded shaft sleeve will never seal properly)
- Cut packing into lengths allowing 1/8" between ends when installed
- Place first ring around shaft and press firmly and evenly into stuffing box
- Continue in the same manner staggering ring joints one quarter of a turn until stuffing box is filled
- Make certain lantern ring is in correct position under pipe connection

STUFFING BOX ASSEMBLY

- Install back stuffing box extension
- Install flush line connection on stuffing box extension
- Install gland plate and compress evenly leaving it finger tight
- Compress packing evenly with gland and leave gland nut finger tight
- With pump running adjust gland with recommended leakage rate

CAUTION: Packing should not be pressed too tight, as this may result in burning the packing and scoring the shaft sleeve.

PUMP DISASSEMBLY

WARNING!!

Whenever any disassembly work is to be done on pump, disconnect power source to driver to eliminate any possibility of starting unit

TO REMOVE ROTATING ASSEMBLY

1. Remove coupling guard and disconnect coupling halves
2. Disconnect flush line from upper half casing
3. Remove bolting from bearing covers and jack the (2) screws to help remove bearing covers
4. Remove bearing locknut on opposite side of motor
5. Remove bearing by holding shaft in place and turning nut behind bearing; bearing will slide out
6. Remove gland plate and split gland
7. Remove stuffing box extension
8. Remove packing, lantern ring and bushing
9. Remove top casing bolting
10. Screw (2) jack screws down to separate upper and lower case
11. Turn jack screws back after separation to prevent interference at reassembly
12. Lift upper casing straight up until clear of impeller
13. Place slings around shaft near the bearing housings and lift shaft assembly
14. Place shaft assembly in a clean, dry work area for necessary disassembly

DISASSEMBLY OF ROTATING ELEMENT

1. Remove pump half coupling
 2. Unscrew sleeve on right side of the pump when facing suction flange
 3. Slide impeller on shaft and remove
- NOTE** DIRECTION OF VANES, IMPELLER MUST BE INSTALLED IN SAME DIRECTION
4. Remove impeller key
 5. Unscrew other sleeve

REMOVAL OF IMPELLER RING

It is not necessary to remove impeller from shaft to replace impeller rings

1. Remove rotating element
2. Remove locking set screws from rings

3. Rings may now be pulled from impeller, cut off with a chisel, or turned off if a suitable lathe is available using original shaft centers - DO NOT CUT INTO BODY OF IMPELLER -
4. When new rings are installed, drill and tap new holes for locking set screws - do not attempt to use old half holes in impeller hub

INSPECTION

1. Visually inspect parts for damage affecting serviceability
2. Check "O" rings and gaskets for cracks, nicks or tears
3. Check packing rings for excessive compression, fraying or shredding and embedded particles
4. Replace if defective in any way
5. Mount shaft between the lathe centers to check eccentricity throughout the entire length, runoff should not exceed .002 in.
6. Bearing surface should be smooth and shoulders square and free of nicks
7. Measure OD of impeller hub or impeller wear rings and ID of casing wear ring
8. Compute diametrical clearance (ID minus OD) and compare with original (.0075" to .0085") radial clearance
9. Surfaces must be smooth and concentric
10. Examine impeller passages for cracks, dents or embedded material
11. Examine shaft sleeves for wear

ASSEMBLY IS THE REVERSE OF THE DISASSEMBLY PROCEDURE

1. All parts, inside and out, should be clean since dirt and grit will cause excessive wear, plus needless shutdown
2. Reinstall sleeve in correct position - 8 1/2" from bearing face to sleeve face (see drawing "PUMP ASSEMBLY")
3. Reinstall impeller with vanes in right direction - Impeller vanes slope must be opposite to pump rotation

Pump rotation is defined viewed from the driver's end

1. Do not lock sleeve shaft with impeller key until impeller has been positioned in center of volute; this may be accomplished by moving sleeve
2. Make certain that casing rings are in proper position; the half raised ring should be on the outside and completely in the lower half casing and ensure ring is fully seated
3. Install casing gasket and do not cut overlap before casing cover is in place and bolted
4. Install upper half, cut gasket on each side of the stuffing box and bore after all cap screws are tightened
5. Install stuffing box bracket and packing afterwards. Insure that packing does not block seal water inlet
6. Install packing flush line
7. Reinstall bearings and bearing covers

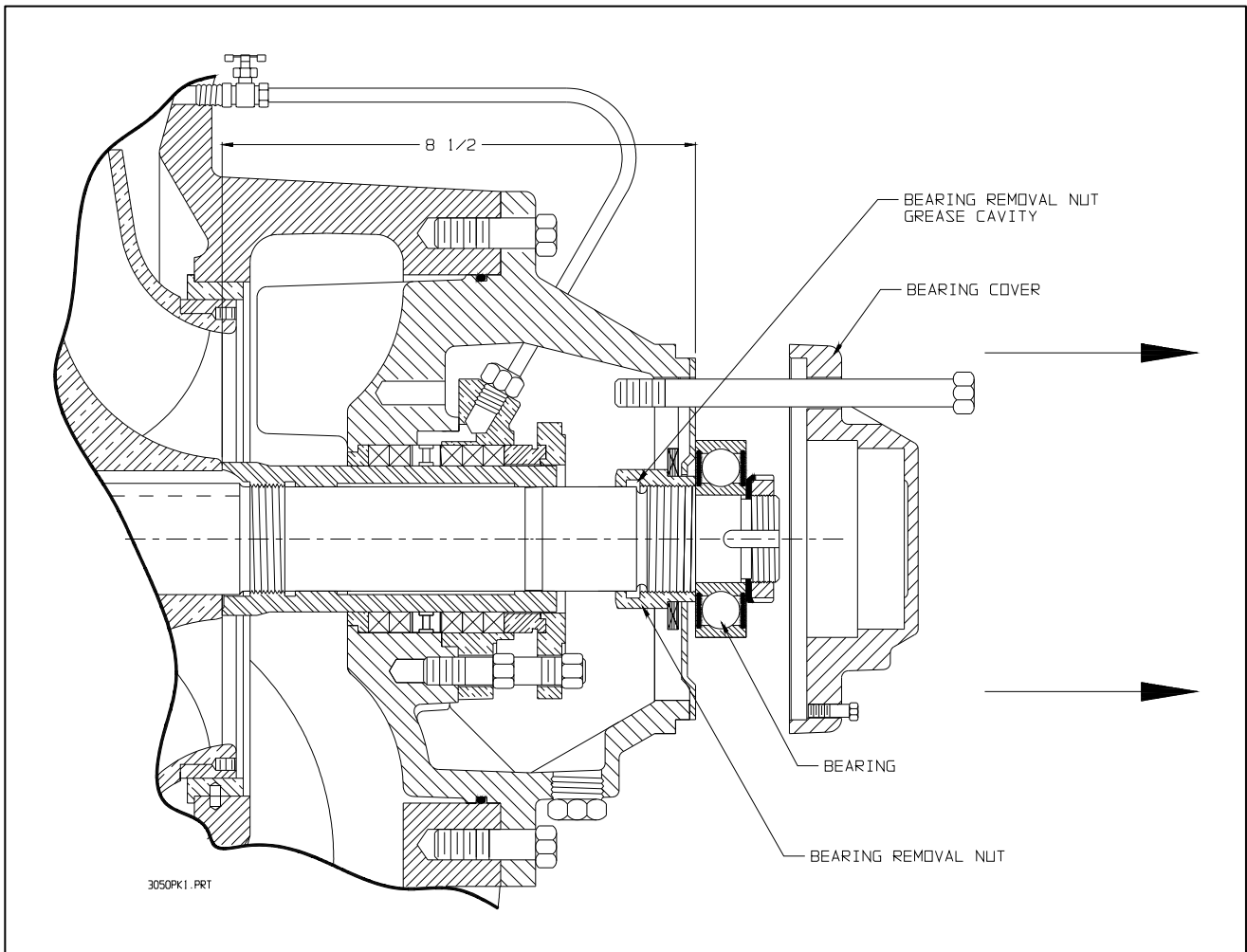

TROUBLE SHOOTING

CAUSES	REMEDY
PUMP WILL NOT START	
Faulty electrical circuit	<ul style="list-style-type: none"> • Make sure both circuit breaker and disconnect switch are in the "ON" position • If the circuit breaker trips when the pump tries to start check horsepower and voltage specified on the schematic and wiring diagram inside the starter door with the pump motor nameplate • Ensure that the pressure switch is working properly and is responding to changes in pressure
Stuffing box too tight or packing improperly installed	<ul style="list-style-type: none"> • Loosen gland swing bolts and remove stuffing box gland halves; replace packing
Impeller locked	<ul style="list-style-type: none"> • Remove obstruction
Excess bearing friction due to wear and dirt	<ul style="list-style-type: none"> • Remove bearings and clean, lubricate, or replace as necessary

PUMP IS NOISY OR VIBRATES	
Stuffing box too tight or packing improperly installed	<ul style="list-style-type: none"> • Loosen gland swing bolts and remove stuffing box gland halves; replace packing
Impeller obstructed	<ul style="list-style-type: none"> • Pressures fall off rapidly when an attempt is made to draw a large amount of water, remove obstruction from impeller
Excess bearing friction due to wear and dirt	<ul style="list-style-type: none"> • Remove bearings and clean, lubricate, or replace as necessary
Foundation not rigid	<ul style="list-style-type: none"> • Tighten foundation bolts or replace foundation if necessary

NO WATER DISCHARGE	
Air pocket or air leakage in suction line	<ul style="list-style-type: none"> • Uncover suction pipe and locate and re-arrange
Suction connection obstructed	<ul style="list-style-type: none"> • Examine suction intake, screen, and suction pipe and remove obstruction
Impeller obstructed	<ul style="list-style-type: none"> • Pressures fall off rapidly when an attempt is made to draw a large amount of water, remove obstruction from impeller
Pump not primed	<ul style="list-style-type: none"> • First warning is a change in pitch of the sound of the driver; shut down the pump

DISCHARGE PRESSURE TOO LOW	
Air leakage in suction line	<ul style="list-style-type: none"> • Uncover suction pipe and locate and re-arrange
Suction connection obstructed	<ul style="list-style-type: none"> • Examine suction intake, screen, and suction pipe and remove obstruction
Stuffing box too tight or packing improperly installed	<ul style="list-style-type: none"> • Loosen gland swing bolts and remove stuffing box gland halves; replace packing
Water seal or pipe to seal obstructed or air leak into pump through stuffing boxes	<ul style="list-style-type: none"> • Loosen gland swing bolt and remove stuffing box gland halves along with the water-seal ring and packing. • Clean the water passage to and in the water seal-ring. Replace water seal-ring, packing gland and packing in accordance with manufacturer's instructions
Impeller obstructed	<ul style="list-style-type: none"> • Pressures fall off rapidly when an attempt is made to draw a large amount of water, remove obstruction from impeller
Speed too low	<ul style="list-style-type: none"> • Check that rated motor speed corresponds to rated speed of pump, voltage is correct, and starting equipment is operating properly
Wrong direction of rotation	<ul style="list-style-type: none"> • With polyphase electric motor drive two wires must be reversed; where two sources of electrical current are available, the direction of rotation produced by each should be checked
Rated motor voltage different from line voltage i.e., 220 or 440 volt motor on 208 or 416 volt line	<ul style="list-style-type: none"> • Obtain motor of correct rated voltage or larger size motor

PUMP WILL NOT STOP	
* Faulty electrical circuit	<ul style="list-style-type: none"> • Is the pressure switch inside the starter properly piped up to the water system? (system side) • Is the stop valve in the piping to the pressure switch open? • Check that pressure switch is working properly by disconnecting one of the pressure switch leads to simulate open contact position • Ensure that pressure switch connection lines have been flushed to clear dirt in piping • Make sure that pressure switch set point is correct according to suction and working pressure • Change manual start handle to automatic
Run period timer defective	<ul style="list-style-type: none"> • Remove jumper if applicable
Pressure too low	<ul style="list-style-type: none"> • Verify pressure switch setting compared to system pressure

* Note: Refer to control panel manufactures installation instructions for other controller related problems.

WARRANTY

Armstrong Darling pumps are guaranteed against defective workmanship and material for a period of twelve months from date of shipment. Should the Armstrong Darling pump fail within the warranty period, our responsibility is limited to the repair or replacement of defective parts provided such are returned to our Plant, transportation prepaid. We do not accept liability for damage or break-down from causes

beyond our control, or the result of reasonable wear nor for repair made, or date attempted to be made without prior sanction, nor for any consequential damage resulting from the failure of a pump. The customer will assume all labor charges incurred in our making the replacement of adjustment of the part.

SERIES 4600 HORIZONTAL SPLIT CASE

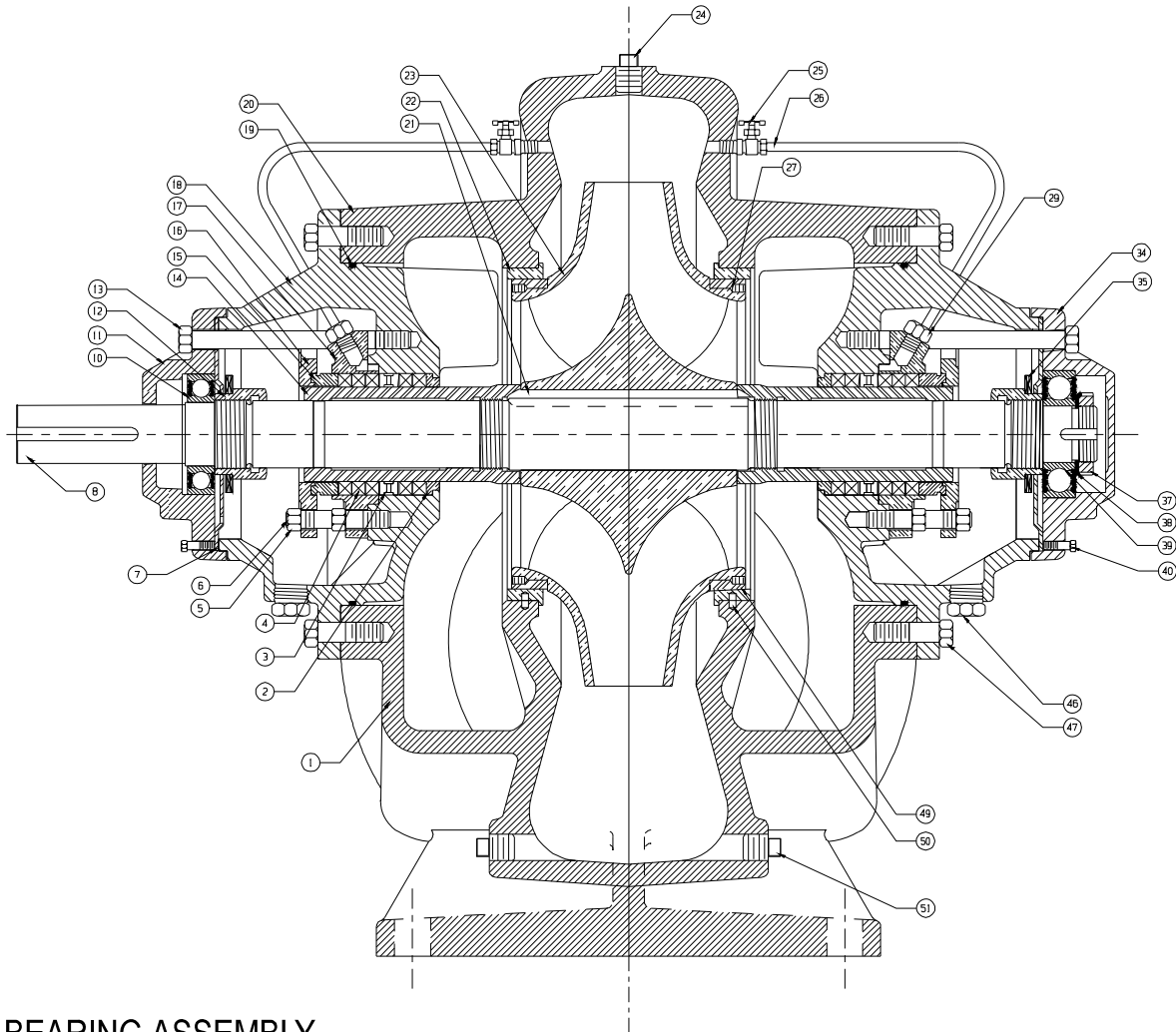

BEARING ASSEMBLY FOR 1 1/8" SHAFT CONSTRUCTION

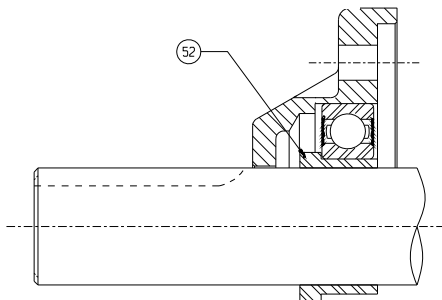

SERIES 4600F HORIZONTAL SPLIT CASE PUMP PARTS LIST

No.	PART LIST	MATERIAL	QTY
1	CASING - LOWER	CAST IRON	1
2*	STUFFING BOX BUSHING	BRONZE	2
3	LANTERN RING	TEFLON	2
4*	PACKING	GRAPHITE	
5	GLAND NUT	STAINLESS STEEL	4
6	GLAND STUDBOLT	STAINLESS STEEL	4
7	RETAINER BEARING	STAINLESS STEEL	2
8*	SHAFT	CARBON STEEL	1
10*	INBOARD BEARING	NSK	1
11	INBOARD BEARING HOUSING	CAST IRON	1
12*	BEARING REMOVAL NUT	BRONZE	2
13	BEARING HOUSING CAP SCREW	CARBON STEEL	6
14*	SHAFT SLEEVE PACKING	STAINLESS STEEL	2
15	SPLIT RING	BRONZE	2
16	PACKING GLAND	BRONZE	2
17	STUFFING BOX EXTENSION	BRONZE	2
18	STUFFING BOX	CAST IRON	2
19*	STUFFING BOX "O" RING	BUNA N 80 DURO	2
20	CASING - UPPER	CAST IRON	1
21*	IMPELLER KEY	CARBON STEEL	1
22*	CASING RING	BRONZE	2
23*	IMPELLER	BRONZE	1
24*	PLUG	CAST IRON	1
25	NEEDLE VALVE	BRASS	2
26	SEAL PIPING	BRASS	2
27	SET SCREW	STAINLESS STEEL	4
29	TUBE CONNECTOR	BRASS	2
34	OUTBOARD BEARING HOUSING	CAST IRON	1
35*	DEFLECTOR	NEOPRENE	2
37	BEARING LOCK NUT	CARBON STEEL	1
38	BEARING LOCK WASHER	CARBON STEEL	1
39*	OUTBOARD BEARING	NSK	1
40	CAP SCREW	CARBON STEEL	4
46	CONNECTION TO DRAIN	CAST IRON	2
47	CAP SCREW	CARBON STEEL	16
49*	IMPELLER RING (OPTIONAL)	BRONZE	2
50	LOCKING PIN	STAINLESS STEEL	2
51	PIPE PLUG	CAST IRON	1
52	BEARING COLLAR	STAINLESS STEEL	1
	*CASING GASKET (NOT SHOWN)	VELOTHERM	1

* RECOMMENDED SPARES



PRE START-UP / POST START-UP CHECK LIST

CENTRIFUGAL PUMPS

START-UP DATE:		ORDER No.:		SERIAL No.:
PUMP SIZE	MIN. SUCT.PRESS.	FLOW	HEAD	VOLT _____ PHASE _____ Hz _____
CHECK THE FOLLOWING AT PRESTART-UP			OK	REMARKS / CORRECTIVE ACTIONS
1. STORAGE Verify equipment for improper storage or mishandling.			<input type="checkbox"/>	
2. INSTALLATION Compare electrical supply to one indicated on motor nameplate. Compare current rating of overload relays and fuses in controller against full load current value on motor nameplate.			<input type="checkbox"/> <input type="checkbox"/>	
3. ALIGNMENT Verify the alignment of driver to pump. (Horizontal Pumps Only) Verify suction and discharge for pipe strain. Do the flanges meet squarely?			<input type="checkbox"/> <input type="checkbox"/> <input type="checkbox"/>	Indicate alignment reading _____
4. ROTATION Manually turn coupling to assure free rotation of pump and motor.			<input type="checkbox"/>	
5. SYSTEM Insure system is free of foreign matter which could damage the pump. Responsible parties present when equipment is energized.			<input type="checkbox"/> <input type="checkbox"/>	
6. DIESEL DRIVEN FIRE PUMP ONLY Engine coolant filled to the proper level? Engine oil filled to proper level? Fuel line from the tank connected to engine (supply and return)? Fuel tank filled with proper diesel fuel? Silencer properly connected to engine and outside? Engine controller wiring connected to engine junction box? Is engine jacket water heater connected to AC power? Batteries charged (MIN.24 HRS PRIOR TO START-UP) and connected to engine?			<input type="checkbox"/> <input type="checkbox"/> <input type="checkbox"/> <input type="checkbox"/> <input type="checkbox"/> <input type="checkbox"/> <input type="checkbox"/> <input type="checkbox"/>	
CHECK THE FOLLOWING AT POST START-UP			OK	REMARKS / CORRECTIVE ACTIONS
6. VIBRATION Upon the occurrence of excessive vibration or noise, was equipment immediately shut down?			<input type="checkbox"/>	
7. FLOW Has flow been established? Take gauge and amperage readings (if motor driven) ? Packing been adjusted to a slight leakage? If pumps are equipped with mechanical seals, has the establishment of a clear source of water to lubricate the seals been made? Is the lubricating seal water pressure a constant 10 to 15 PSI above the discharge of the pump?			<input type="checkbox"/> <input type="checkbox"/> <input type="checkbox"/> <input type="checkbox"/> <input type="checkbox"/>	
8. READINGS Flow, pressure and amperage readings taken immediately after correction of all problems and restart.			<input type="checkbox"/>	

CUSTOMER'S REPRESENTATIVE(S) WITNESSING TESTS:

ARMSTRONG PUMP DIV., REPRESENTATIVE CONDUCTING TESTS:

WITNESS _____

WITNESS _____

DATE: _____

DATE: _____

S. A. Armstrong Limited
 23 Bertrand Avenue
 Toronto, Ontario
 Canada, M1L 2P3
 T: 416 755 2291
 F: 416 759 9101

Armstrong Integrated Limited
 Wenlock Way
 Manchester
 United Kingdom, M12 5JL
 T: +44 (0) 8444 145 145
 F: +44 (0) 8444 145 146

Armstrong Design Private Limited
 (Unit 1- Armstrong Manufacturing Center)
 490-L, 4th Phase, Peenya Industrial
 Area, Bangalore, India 560 058
 T: +91 (80) 4906 3555
 F: +91 (80) 2334 3535