

INSTALLATION AND OPERATING INSTRUCTIONS

COMMERCIAL PUMPS Series 4610 Base Mounted Pumps

CE CONFORMITIES

For declaration of Conformities, contact Armstrong.

INTRODUCTION

This leaflet contains specific information regarding the safe installation, operation and maintenance of 4610 pumps. These instructions must be read and understood by anyone responsible for the installation, operation and maintenance of the equipment. Our equipment has been designed and constructed to be safe and without risk to health and safety when properly installed, used and maintained, providing that our instructions are carefully adhered to. If clarification is needed on any point please contact Armstrong quoting the equipment serial number.

WARNING SYMBOLS



Safety instruction where an electrical hazard is involved.



Safety instruction where non-compliance would affect safety risk.



Safety instruction relating to safe operation of the equipment. (ATTENTION)

INSTRUCTIONS FOR SAFE USE



No installation of this equipment should take place until this leaflet has been studied and understood. Handling, transportation and installation of this equipment should only be undertaken with the proper use of lifting gear, see diagram.

TEMPERATURE



Where under normal operating conditions, the limit of 68°C/155°F (Restricted Zone) for normal touch, or 80°C/176°F (unrestricted zone) for unintentional touch, may be experienced, steps shall be taken to minimise contact or warn operators/users that normal operating conditions will be exceeded.

NOISE LEVELS



Maximum sound pressure level of 70dB(A) @ 1 meter unless stated otherwise as shown in table below.

Motor kW	30	37	45	55	75	90	110	132	160
2 Pole	74	74	78	78	79	79	81	81	81
4 Pole					74	74	77	77	77

STORAGE

- Store in a dry place.
- Protect against dirt, damage and frost.
- If units are to be stored for long periods then the shaft should be rotated by hand every three months.
- Do not remove suction and delivery blanks until ready to connect pipework.

LIFTING METHOD

Use slings as shown in diagram to lift set. Do not use motor eye bolt to lift set. See delivery note for weight of set.

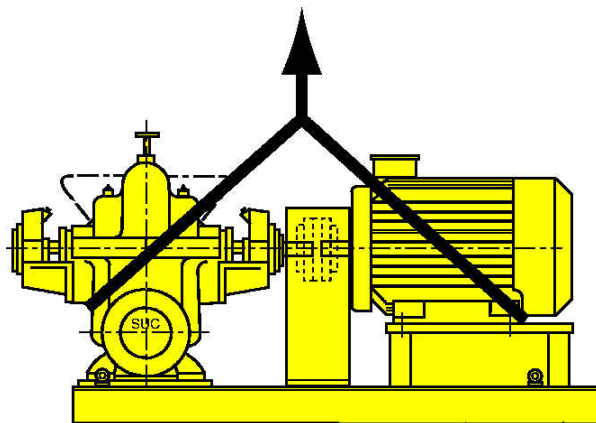

LIMITATIONS

See pump nameplate for speed, duty and maximum pressure/temperature limitations. These limits must not, under any circumstances, be exceeded without prior consultation with Armstrong

LOCATION

Locate the pump so that it is accessible for inspection and maintenance purposes. The ambient air temperature must NOT exceed relevant limitations of BS4999 and BS5000 for ventilation; air movement shall NOT be restricted.

GENERAL

Series 4610 pumps are horizontal split casing pumps. The casing is split along the shaft axis so that normal maintenance work can be carried out without disturbing the position of either the pump or pipework. The primary application of these pumps is water, although other fluids such as ethylene glycol solutions may be pumped when specified with the order. The maximum working pressure of the pumps is stated on the pump nameplate. The standard temperature range is 5°C to 125°C. Temperatures outside this range can be accommodated when a suitable mechanical seal is fitted. The actual temperature limit is shown on the pump nameplate.

The following pump data will be found on the pump nameplate.

- Pump size and model
- Pump serial number
- Pump speed
- Specified flow rate
- Specified head
- Maximum pressure
- Maximum temperature

If in doubt contact Armstrong quoting the pump serial number

SAFETY ELECTRICAL

Before dismantling the pump isolate the power supply to the motor and any automatic starting circuits. The motor should be wired in line with the motor manufacturer's instructions (in terminal box) and existing regulations. When washing down keep any water well away from any electrical connections or electrical devices, unless they are hose proof.

MECHANICAL

- Do not carry out any maintenance on the pump whilst the unit is in operation. (Except motor bearing lubrication: see motor section).
- The surface temperature of the pump might be hot!
- Venting the pump could result in a slight escape of hot water or steam.
- When lifting the pump ensure that, the lifting equipment is adequate to take the weight of the pump. The pump weight is issued with the acknowledgement and can be obtained from Armstrong
- Lift the pump using the eyebolts in the bedplate or use a sling around the major cast components (see earlier illustration) of the pump. Never use the motor eyebolts to lift the whole pump.
- Ensure that the pipework does not put any strain on the pump flanges.
- Ensure all guards are in place before starting the pump.



- Where old gaskets containing asbestos have to be scraped from joint faces, thoroughly wet the material to avoid any dust.
- Use only genuine parts.

INSTALLATION

1. LOCATION

- Locate the pump so that it is accessible for inspection and maintenance purposes. The distance between the air intake of the motor and wall or other machinery must be at least four times the diameter of the air intake opening. The warm exhaust air leaving the motor must not be drawn in again.
- The ambient air temperature should not be allowed to exceed 40°C, unless Armstrong have been consulted and the load on the motor checked.
- The pump should be mounted on a foundation capable of supporting the unit without vibration when the pump is operating. The top surface of the foundation should be well scored and grooved before the concrete sets to provide a bonding surface for the grout. Foundation bolts should be set in the concrete. Allow enough bolt length for grout, shims, lower baseplate flanges, nuts and washers. The foundation should be allowed to cure for several days before the baseplate is shimmed and grouted.

2. BASEPLATE SETTING

- Use blocks and shims under the base for support at the foundation bolts and midway between bolts to position base approximately 25mm above concrete foundation with bolts extending through holes in baseplate.
- By adding or removing shims under base, level the pump shaft and flanges. Draw foundation bolt nuts tight against baseplate and observe pump and motor shafts and couplings for alignment. Check to make sure the piping can be aligned to the pump flanges without placing pipe strain on either flange. Grout baseplate in completely and allow grout to dry thoroughly before attaching pipework to pump.

3. GROUT PROCEDURE

- Grout compensates for uneven foundations, distributes weight of unit and prevents movement. Use an approved, non shrinking grout as follows, after setting and leveling the unit.
- Build a strong form around foundation to contain grout. Soak top of concrete foundation thoroughly and remove surface water. Baseplate should be completely filled with grout and if necessary, drill vent holes to remove trapped air. After the grout has thoroughly hardened, check the foundation bolts for tightness.
- Check alignment after foundation bolts are tightened. Approximately 14 days after or when the grout has thoroughly dried, apply an oil based paint to the exposed edges of the grout to prevent air and moisture from coming into contact with the grout.

4. PIPEWORK

- Care should be taken to ensure that no dirt or foreign matter enters the pump casing during pipework installation.
- The pipework must not put any strain on the pump flanges. *To avoid external stress being imposed it is essential that the weight of the pipe is supported by independent means and that all flanges are square and parallel.* The pipework should be designed to avoid expansion imposing stresses on the pump flanges. The diameter of the suction pipe should not be less than the internal diameter of the pump inlet and should be as straight and free from bends as practicable. It is recommended that isolating valves are fitted on both suction and delivery branches, a non return valve is fitted in the delivery pipe, and a strainer in the suction pipe.

5. CHILLED WATER PUMPS

These pumps - when fitted with a suitable mechanical seal - are suitable for glycol solutions in chilled water systems. However to achieve the maximum seal life it is recommended that glycols are used that are produced specifically for chilled water systems, with a limited amount of inhibitors.

6. FLUSHING

Under no circumstances should the pump be used for flushing out the system. The pump should be out of line or bypassed during flushing. Chemical additives to the system should be drip fed on the *discharge* side of the pump

7. VIBRATION ISOLATION

On sites where it is important that the transmission of vibration to the pipework and building structure is kept to a minimum, it is recommended that the pumps are mounted on a concrete filled inertia base, supplied by Armstrong. The base is then mounted on anti-vibration mountings. Alternatively, the mountings can be used without the inertia base fixed directly to the pump baseplate. Flexible pipe connectors must be used when anti-vibration mountings are used, and should also be used to stop the adjacent pipework imparting forces on the pump flanges during thermal expansion and contraction. See separate instructions for all these products.

8. COUPLING ALIGNMENT

Before despatch from the factory, the pump unit is correctly aligned on its base using laser alignment. However a certain amount of deformation of the bedplate is possible during transit so it is essential to check and adjust if necessary the alignment when the pump is fully installed. A flexible coupling will only compensate for a small amount of misalignment and should not be used to compensate for excessive misalignment of pump and motor. Inaccurate alignment results in vibration and excessive wear on the bearings, sleeve or shaft wear rings. Failure to check alignment before start up will invalidate the pump warranty!

Firstly the two coupling hubs should be just touching the lips on either face of the rubber element. To check parallel misalignment of the coupling place a straight edge across the coupling at the top, bottom and sides. The allowable parallel misalignment is as follows:

Coupling Diameters	Allowable Parallel Misalignment
Up to 124mm	0.25mm
130 to 180mm	0.40mm
Over 180mm	0.50mm

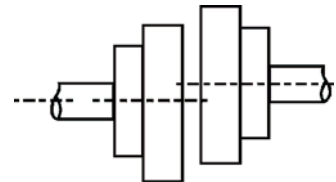
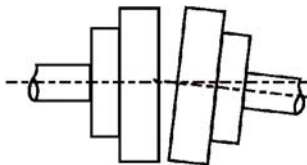

Figure 1 - Parallel Misalignment

These are the maximum figures, and every effort should be made to obtain a more accurate alignment, as this will prolong the life of the bearings and coupling rubber element.

To check *angular misalignment* use outside calipers or a vernier to measure the assembled length (near outside diameter) at the top, bottom and sides. The maximum angular misalignment is 1°. This equates to a maximum difference in length between the opposite sides as shown below:

Coupling Diameters	Allowable Difference in Length
Up to 124mm	1.2mm
130 to 180mm	2.2mm
Over 180mm	3.5mm



Again these are maximum figures, and Armstrong strongly recommend that the most accurate alignment possible is obtained before the pump is run.

Figure 2 - Angular Misalignment

9. GLAND ARRANGEMENT

The normal shaft sealing arrangement is a mechanical seal. However, occasionally gland packing will be used. Gland packing needs special attention during installation and the run in period and specific packing instructions will accompany the pump in these cases.



The motor should be connected and operated in accordance with the motor manufacturer's instructions and should be earthed etc. to comply with the latest I.E.E. regulations.

10. STAR/DELTA MOTOR STARTERS

When used on centrifugal pumps, star/delta starters can cause problems if the setting of the electronic timer gives a dwell period of more than 40 milliseconds when switching from star to delta.

A long dwell period combined with the low inertia of the centrifugal pump rotating element and the high drag effects of the pumping medium can lead to a significant drop in speed during the switch over from star to delta. This results in a large kick as the pump is accelerated almost instantaneously to full delta speed. Where pumps start and stop regularly accumulative damage will occur. Therefore, the starter should be adjusted to, or fixed at, **40 milliseconds** maximum.

It is recommended that mechanical interlocks are fitted between the star and delta contactor blocks on all star/delta starters.

11. OPERATION BEFORE STARTING

Check that the pump has been installed in accordance with the preceding installation instructions. Check that the pump turns freely by hand. Ensure that all protective guarding is in position and securely fixed.



12. PRIMING

The pump must never be run dry or part full as this may damage the internals. On pressurised systems this simply means opening the aircock on top of the pump to expel the air.

Where the pump is to operate with a suction lift, the pump and suction pipework should be filled either using a vacuum pump or manually from a point on the discharge side of the pump. The aircock can then be opened to vent the pump. The water level should remain constant, proving that the foot valve is holding.

13. STARTING

In general, the following procedure should be followed.

- a. Close the discharge valve
- b. Ensure that the suction valves are open
- c. Prime and vent the unit
- d. Start the motor and check the direction of rotation is correct as indicated by the direction arrow. If it is incorrect, change over any two of the three supply leads on a three phase motor. Single phase motors should rotate the correct way. If they do not, then check the inside of the terminal box for instructions
- e. The discharge valve should now be slowly opened
- f. DO NOT operate the pump with a closed discharge valve for more than a few minutes
- g. During the initial run, noise may be due to air in the system. If this occurs open the aircock (when fitted) until the air is exhausted
- h. When a mechanical seal is fitted, no adjustment is necessary, and any slight leakage which may initially occur will be taken up when the seal faces bed in
- i. Check that the motor is not overloaded. Overloading may occur if the pump is discharging into an empty system, when the head will temporarily be lower than that for which the pump was designed
- j. For packed gland pumps see separate instructions

14. STOPPING

- a. Slowly close the delivery valve and shut down driving unit in accordance with the manufacturers instructions.
- b. Shut off external sealing liquid, if supplied, to relieve stuffing box pressure.
- c. Successful operation of the pump depends on accurate alignment of the pump. It is recommended to re-check the alignment after preliminary run.

15. MAINTENANCE - PLANNED MAINTENANCE

The pump should be inspected weekly for leaks and any increase in noise or vibration. The mechanical seal needs no maintenance and should be replaced only if the pump begins to leak or when the pump is stripped. Packed glands need regular maintenance. This is detailed in separate instructions. The recommended bearing maintenance is described below.

After a long period of service, wear will occur in parts of the pump, necessitating the renewal of parts. The most likely to be affected are the mechanical seal or gland packing, impeller, impeller neck rings, bearings, sleeves and coupling element.

We recommend the following spares be kept with the pump to minimise down time:

Two years operation:

Mechanical seal or gland packing, gaskets, bearings.

Three years operation:

Mechanical seal or gland packing, gaskets, bearings, neck rings, sleeves, sleeve nuts, glands and logging rings.

Five years operation:

One rotating element.

16. PUMP BEARING LUBRICATION

The pumps are fitted with high performance ball or roller bearings which require lubrication and a greasing nipple is provided on the bearing housing. Pumps are despatched with the bearings adequately lubricated. The lubricant should be replenished with one shot from a grease gun or one turn of the lubricant cap at 3-6 month intervals, depending on the operating time. The recommended grease is Mobilux No.3 or Mobil Grease MP.

17. MOTOR BEARING LUBRICATION

Sealed for life bearings:

The motor bearings will usually be double shielded ball bearings, and are pre-packed with grease or ("sealed for life"). In the unlikely event of a bearing of this type being faulty the bearings need to be replaced. They cannot be re-greased.

Re-lubrication of bearings:

Some larger motors have open type bearings, and are equipped with greasing nipples for re-lubrication during operation.

The following table gives the recommended re-lubrication intervals in operating hours, of motors with grease nipples. One shot from a grease gun will normally suffice.

Nominal RPM	Frame Size			
	160-180	200-225	250-280	315-355
1450	5000	4000	3000	3000
2900	10000	8000	6000	3000

The following lithium based greases are recommended.

JOK Greases	JON Greases (Higher Temp.)
BP/ENERGREASE LS3	SHELL! AL VANIA G3
MOBIL/MOBILUX 3	SHELL! AL VANIA R3
ARAL/ARALUB HL3	ARAL/ARALUB 4340
ELF/ROLEXA 3	ESSO/BEACON/3

GREASE AND BEARING REPLACEMENT

Irrespective of operating hours, the grease should be completely changed at least every 3 years due to ageing. For re-charging with grease the pump/motor should be dismantled to the extent necessary, the bearing replaced and charged with new grease. Fill the hollow spaces of the bearings with grease, flush with the outside faces. To avoid excessive grease in bearing assemblies, bearing caps should be charged with grease. The amount of grease to be filled in the bearing should be about 1/3 of its internal volume. It is recommended that, when removing bearings, an extraction device is used after slightly heating the inner ring. For installation, heat the ball bearings or the inner ring of the roller bearings to approximately 80°C and slip them on to the shaft. If heating equipment is not available ensure that the bearing is fitted evenly, without crossing, using light blows on the inner ring. Heavy blows will damage the bearings and must be avoided. Use extreme care and ensure clean conditions during dismantling and assembly.

18. DISMANTLING PROCEDURE

- a. Drain the pump by removing the drain plug and opening the air vent
- b. Remove all casing main joint nuts and dowel pins
- c. Remove flush piping
- d. Loosen all insert joint nuts at both ends
- e. Insert a screwdriver or peg bar into the slot between the upper and lower casing halves and separate the halves, lift off the upper casing half
- f. Tap the stuffing box insert with a soft headed hammer to break the seal between the stuffing box insert and the lower half casing and lift out the rotating element from the lower half casing
- g. Remove hexagon head screws from each bearing housing and remove the bearing housing from the bearing
- h. Remove bearing locknut and washer from the non drive end side of the shaft and using a puller, remove the bearing from the shaft. Remove the drive end bearing in the same manner
- i. Remove oil seals and shoulder rings from the shaft
- j. Slide stuffing box inserts off the shaft
- k. Drive mechanical seal seat from the stuffing box inserts

- l. Slide the mechanical seal rotating elements off the shaft. Scribe a line on the shaft flush with the end of each mechanical seal locating ring. Slacken the hexagon socket set screws from the locating rings and slide locating rings off the shaft.
- m. Remove the casing rings from the impeller
- n. Unscrew impeller locknut from the drive end and slide off shaft
- o. Remove impeller, slide back impeller key and remove the other impeller locknut from the drive end. Remove the impeller key

19. ASSEMBLY PROCEDURE

- a. Check 'O' ring for cuts or flaws, discard if faulty, lubricate and roll 'O' ring in groove of each sleeve
- b. Wipe over the shaft with clean light oil. Screw shaft sleeve onto the shaft at the non drive end
- c. Place impeller key into keyway and tap milled end right home under impeller locknut
- d. Check impeller for correct rotation and slide onto shaft from drive end
- e. Screw shaft sleeve onto shaft at drive end and using a spanner lock up tight against the impeller hub and first sleeve
- f. Slip casing rings onto impeller
- g. Slide locating rings and mechanical seal rotating elements onto either end of the shaft. Use the hexagon socket screws to lock the mechanical seal locating ring into position
- h. Press mechanical seal stationary element into each insert
- i. Check 'O' rings for cuts and flaws, discard if faulty. Lubricate and roll 'O' ring into groove in each insert
- j. Slide insert over shaft with guide vane at top position
- k. Fit shoulder ring onto shaft then press oil seal into insert. Ensure no foreign particles should enter the bearing assembly
- l. Heat ball bearing to approximately 80°C using hot plate or oil bath. NOTE: Do not exceed 120°C
- m. Slide the heated bearing onto shaft to abut shoulder ring, non drive end. Place locking washer onto the shaft and screw up bearing locknut using a spanner. Lock up tight against bearing. Bend the washer in the slot of the bearing locknut
- n. Cool the bearing to ambient temperature and coat both sides with 40 grams. of recommended grease
- o. Coat the inside of the bearing housing with grease and slide into place over the bearing. Secure bearing housing to insert with hexagon head screws
- p. At coupling end heat bearing to approximately 80°C using hot plate or oil bath. NOTE: Do not exceed 120°C.
- q. Slide the heated bearing onto the shaft to abut the shoulder ring at the coupling end
- r. Cool the bearing to ambient temperature and coat both sides with 40 grams of recommended grease
- s. Coat the inside of the bearing housing with grease and slide into place over bearing. Secure the bearing housing to the insert with the hexagon head screws
- t. Set rotating element in the pump bottom half casing. Locate both insert tongues in their respective casing grooves. Locate pins in their respective slots. Correct any excessive 'O' ring buckling. Check that the impeller is centralised in the casing +/- 2.5mm and that there are no rubs
- u. Install casing gasket with light coat of grease on both gasket surfaces. Carefully align the inner edge of the gasket with insert 'O' rings
- v. Lower the casing upper half into place and engage casing joint nuts loosely. NOTE: when installing casing upper half make sure that the 'O' rings are not cut or pinched and the gasket is hard against the 'O' rings. Insert casing joint dowels and drive home. Tighten the joint nuts in a diagonal sequence
- w. Rotate the shaft by hand to ensure that the rotating element is free from rubbing and binding

20. FAULT FINDING CHART

Symptoms										Possible Causes	Remedies		
Pump fails to deliver	Low delivery rate	Low developed pressure	Pump delivery fails after start	Pump does not prime	Motor not starting	Protective device trips	Motor overheating	Pump vibrates excessively	Pump noisy			Low motor bearing life	Pump seized
												Pump not primed	Prime the pump. see "Operation- Priming"
												Suction line not filled	Fill the system; Vent the highest point
												Air or vapour pocket in suction line	Vent the system and the pump
												N.P.S.H. available too low (cavitation)	Increase pressure at pump suction
												Inlet of suction pipe insufficiently submerged	Raise the water level and vent the pump
												Blocked suction	Remove blockage
												Suction lift too high	Check pump selection/sizing
												Air leaks in suction line, gland or pump joints	Check foot valve
												Incorrect rotation	See "Operation-Starting -4"
												Speed too low	Check motor wiring against nameplate
												Total head of system higher than that of pump	Consult Armstrong
												Impeller damaged	Replace impeller
												Total head of system lower than that of pump	Increase system resistance
												S.G. too high	Consult Armstrong
												Operation at low capacity	Consult Armstrong
												Poor foundation	Secure in line with "Installation-Mounting"
												Rotating element out of balance	Consult Armstrong
												Shaft running out of concentricity	Re-align or replace shaft
												Misalignment of pipework	Correct in line with "Installation-Pipework"
												Incorrect bearing greasing	Grease in line with "Maintenance-Greasing"
												Starter set incorrectly	Check setting against motor nameplate
												Capacitor failure	Check voltage, replace if necessary
												Loose electrical connections	Check terminal connections
												Supply failure	Check supply to motor terminals
												Motor overload	Reduce load or use larger motor
												Phase failure	Check switchgear and supply circuits
												Incorrect connection on stator windings	Check motor wiring against nameplate
												Short circuit on windings	Check winding insulation resistance

21. Cross Sectional View (Typical)

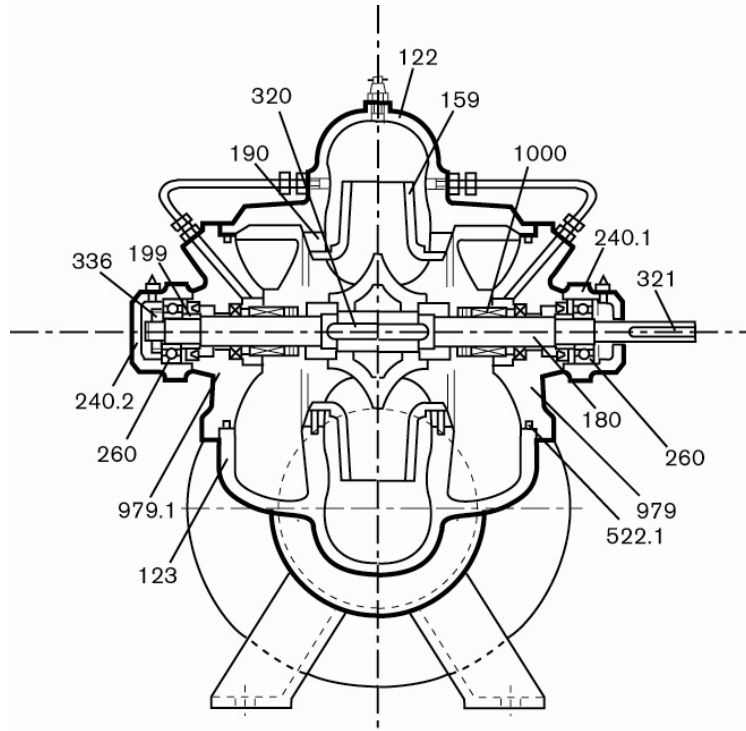

Interchangeability of Components

Part No.	Name of Part	Total No. of Parts	Pump Model																
			Unit 0		Unit I						Unit II								
			50-300A	50-300B	80-300	80-380	100-240	100-290	125-240	125-300A	125-300B	100-380	150-300	150-380A	150-380B	200-300	200-380	250-300	250-380
122	Casing Upper Half	14	1	1	2	3	4	5	6	7	7	8	9	10	10	11	13	12	14
123	Casing Lower Half	14	1	1	2	3	4	5	6	7	7	8	9	10	10	11	13	12	14
159	Impeller	17	1	2	3	4	5	6	7	8	9	10	11	12	13	14	15	16	17
180	Shaft	6	1	1	2	2	2	2	3	3	3	4	4	4	4	5	5	5	6
190	Casing Wear Ring	8	1	1	2	3	4	2	5	5	5	6	6	6	6	7	8	7	8
199	Shoulder Ring	7	1	1	2	2	3	3	3	4	4	4	5	5	5	6	6	7	7
240.1	Bearing Housing (Drive End)	3	1	1	2	2	2	2	2	2	2	3	3	3	3	3	3	3	3
240.2	Bearing Housing (Non Drive End)	3	1	1	2	2	2	2	2	2	2	3	3	3	3	3	3	3	3
260	Bearing	3	1	1	2	2	2	2	2	2	2	3	3	3	3	3	3	3	3
320	Key (Impeller)	6	1	1	2	2	2	2	3	3	3	4	4	4	4	5	5	5	6
321	Key (Coupling)	3	1	1	2	2	2	2	2	2	2	3	3	3	3	3	3	3	3
336	Bearing Locknut	3	1	1	2	2	2	2	2	2	2	3	3	3	3	3	3	3	3
522.1	'O' Ring (Insert)	5	1	1	2	2	2	2	3	3	3	3	3	3	4	5	4	5	
979	Insert (Drive End)	6	1	1	2	2	2	2	3	3	3	4	4	4	4	5	5	5	6
979.1	Insert (Non Drive End)	6	1	1	2	2	2	2	3	3	3	4	4	4	4	5	5	5	6
1000	Mechanical Seal	3	1	1	2	2	2	2	2	2	2	3	3	3	3	3	3	3	3

NOTE: The use of spare parts not supplied by Armstrong will invalidate guarantee. The units must also be installed and maintained as our Operating and Maintenance Manual during the warranty period. Failure to adhere to any of the above will invalidate all guarantees and product responsibility of Armstrong. Pumps must not be used for flushing.

22. Cross Section View (Typical)

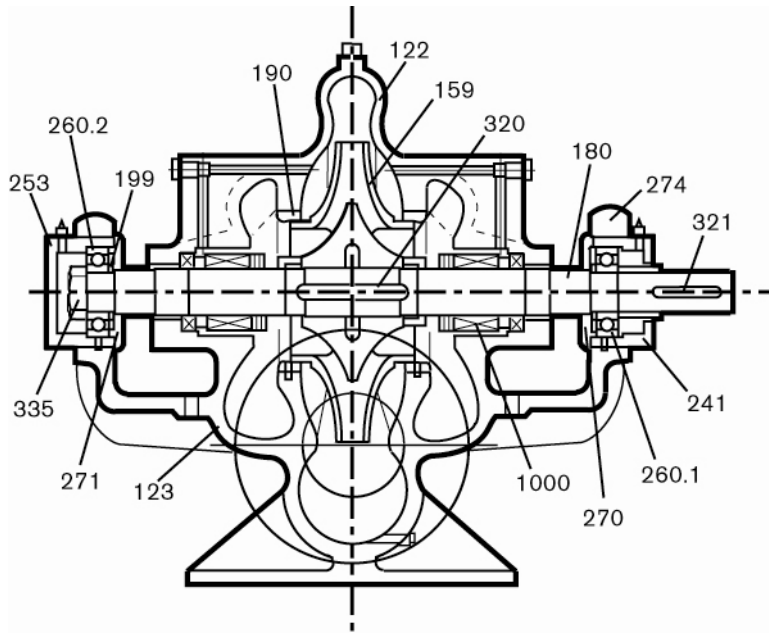

Interchangeability of Components

Part No.	Name of Part	Total No. of Parts	Pump Model					
			150-460	250-460	250-560	300-340	300-390	300-400
122	Casing Upper Half	6	1	2	3	4	5	6
123	Casing Lower Half	6	1	2	3	4	5	6
159	Impeller	6	1	2	3	4	5	6
180	Shaft	4	1	2	3	4	2	3
190	Casing Wear Ring	6	1	2	3	4	5	6
199	Shoulder Ring	2	1	-	-	-	2	-
241	Bearing Cartridge (Drive End)	4	1	2	3	2	3	4
253	Bearing Cartridge (Non Drive End)	4	1	2	3	4	2	3
260.1	Bearing (Drive End)	3	1	2	3	1	2	3
260.2	Bearing (Non Drive End)	3	1	2	3	1	2	3
270	Bearing Cover Drive End	4	1	2	3	4	2	3
271	Bearing Cover Non Drive End	4	1	2	3	4	2	3
274	Bearing Cap D.E. & N.D.E.	4	1	2	3	4	2	3
320	Key (Impeller)	6	1	2	3	4	5	6
321	Key (Coupling)	6	1	2	3	4	5	6
335	Bearing Lock Nut	4	1	1	2	2	2	2
1000	Mechanical Seal	3	1	2	3	3	2	3

Armstrong Holden Brooke Pullen
Wenlock Way
Manchester
United Kingdom, M12 5JL
T: +44 (0) 161 223 2223
F: +44 (0) 161 220 9660

Sales & Service Office
21 Ormside Way
Holmethorpe Industrial Estate
Redhill, Surrey, RH1 2NT
T: +44 (0)173 737 8100
F: +44 (0)173 737 8140

S. A. Armstrong Limited
Bertrand Avenue
Toronto, Ontario
Canada, M1L 2P3
T: (416) 755-2291
F: (416) 759-9101



© S.A. Armstrong Limited 2010