



DESIGN ENVELOPE

6800Q
Booster packages

SOLUTION OUTLINE

FILE NO: 100.141N
DATE: JUNE 2024

SUPERSEDES: NEW
DATE: NEW

DESIGN ENVELOPE VALUE

Armstrong Design Envelope Booster packages combine vertical multi-stage pumps with high-efficiency, variable-speed motors and advanced controls to provide consistent, reliable water pressure.

Assembled and tested to design conditions in an ISO-certified facility

Lowest operating cost

Lowest total cost of ownership

Leading energy efficiency

Compact footprint

Easy to operate and maintain

In buildings of all types, peak levels of demand for water occur in limited time periods. Because of these usage patterns, a booster package operates at part-load for the majority of any given day.

DESIGN ENVELOPE VS. CONSTANT SPEED: ACCURACY IN MATCHING DEMAND

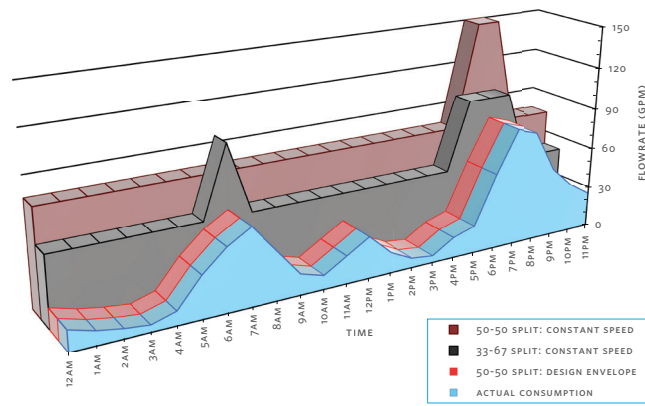

Operating at levels above the current demand causes unnecessary wear on equipment and shortens the operating life. By operating only at the speed required to meet the current flow demands, Design Envelope boosters reduce costs for energy and water and reduce equipment wear.

DESIGN ENVELOPE

UP TO
80%
ENERGY
SAVINGS

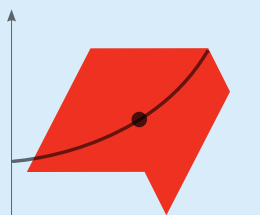
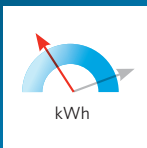

at 50% design flow

Water demand not only shifts throughout the day, it can also change through the life of a building. The demand profile of building can shift over time, due to:

Changes to fixtures

Changes to building design

Installation of backflow preventer

Pipe corrosion and scaling

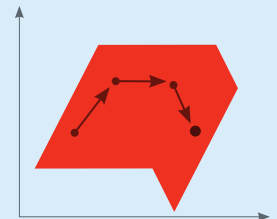

The Design Envelope approach to sizing ensures that booster capacity can accommodate changes in the demand profile over the life of your building. This protects you against costly and time-consuming system rework.



The Advantages of Permanent Magnet Motor Technology in Booster Packages

Booster Packages are the hardest working pumps in a building. Design Envelope Permanent Magnet motors make this vital system better and more cost effective than ever.

Water demand in residential, commercial & industrial buildings

Flow Capacity	Portion of Operating Hours	
	Commercial/ Residential	Industrial
10% or less	30%	1%
30% or less	65%	6%
50% or More	20%	80%

FLOW PROFILES FOR STANDARD COMMERCIAL, RESIDENTIAL & INDUSTRIAL BUILDINGS

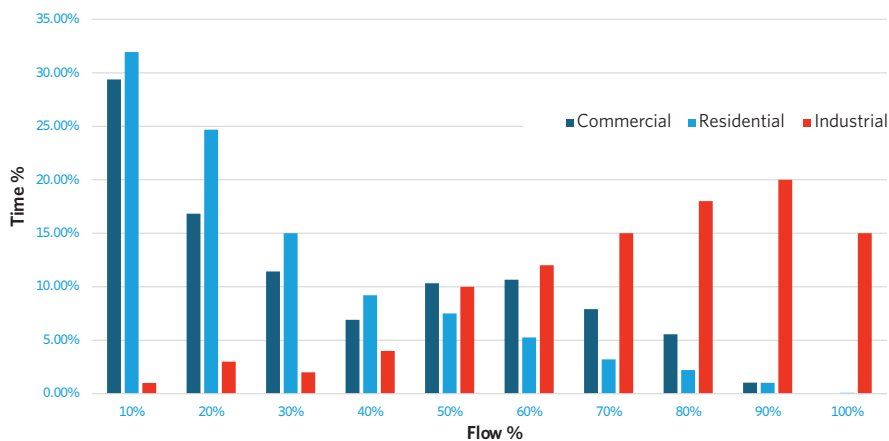

600.00

'C'

5.

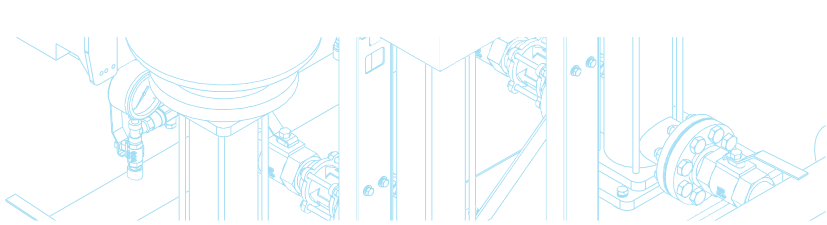
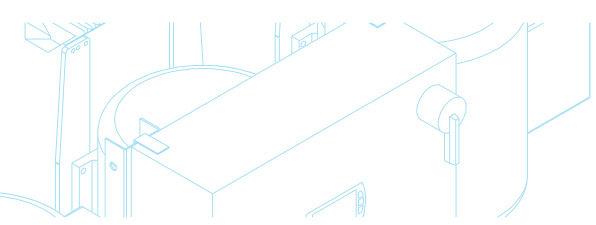

EFFICIENCY & ENERGY SAVINGS DEPM VS IE3 (WITH INVERTER)

Design Envelope Permanent Magnet (DEPM) motors are more efficient than traditional variable speed induction motors.

DEPM motors provide a clear efficiency advantage across the operating range and the difference in efficiency levels is even greater at lower speeds.

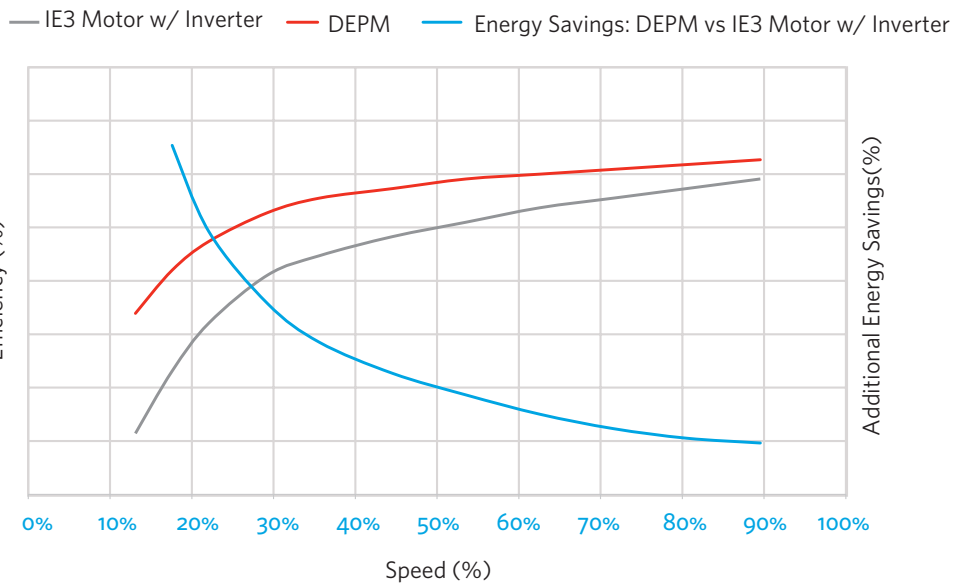

Ownership advantages of DEPM motor technology

- Reduced maintenance requirements
- Longer uninterrupted operating times
- Smaller size and reduced weight
- Ultra-quiet operation
- Larger range of operating speeds
- Maximum design and installation flexibility

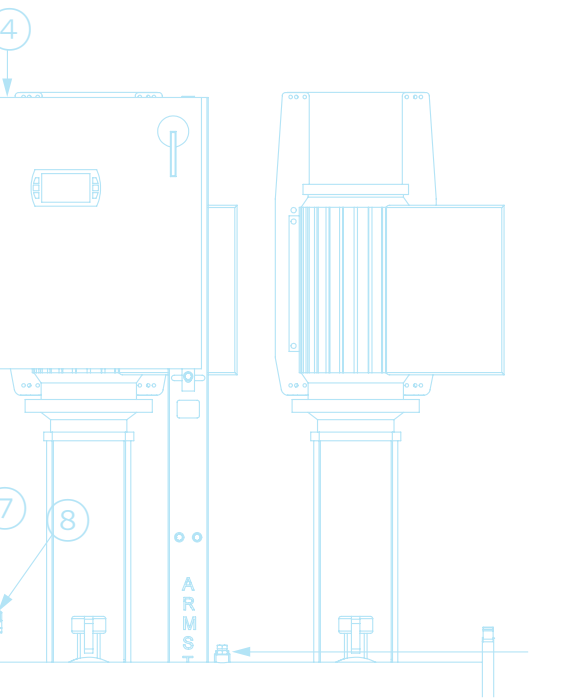

Embedded control logic ensures optimum efficiency at all times, adjusting pump speed and staging pumps on and off as needed during periods of high, low and no demand.

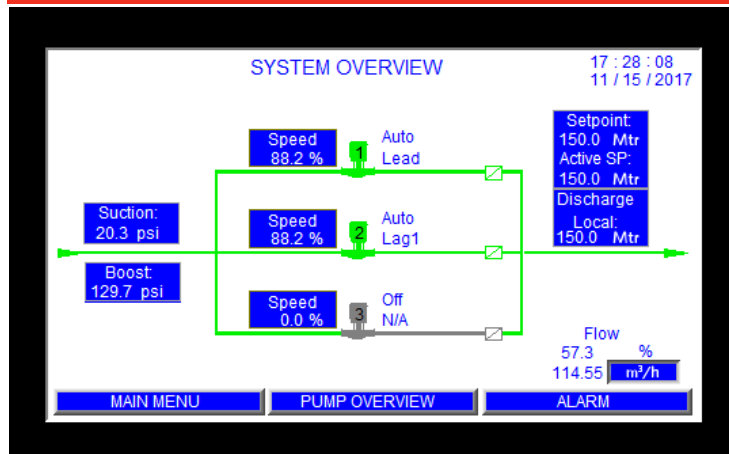
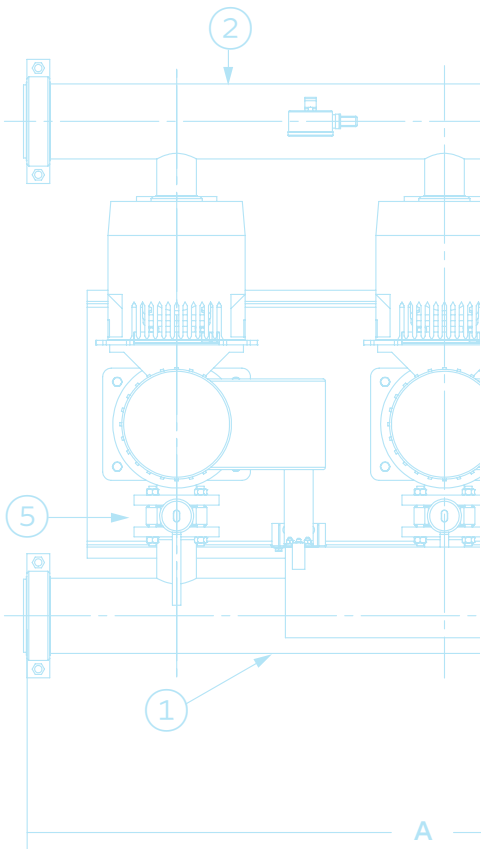

Full integration for advanced mechanical and digital capabilities

Armstrong Design Envelope boosters integrate pumping components with advanced digital controllers for:

Optimal energy savings

Controls curves are programmed at Armstrong's state of the art factory; with every booster undergoing full functional testing to design conditions prior to shipment.

Easy installation

No additional wiring or mounting is required on-site.

Reduced downtime

Individual pumps can be serviced and replaced without the need to interrupt water supply to building occupants.

Single source

Armstrong supplies all components of the booster package.



KEY BENEFITS

LOWEST ENERGY COSTS

Design Envelope Boosters combine advanced controls with IE3 efficiency induction motors and new DEPM motors that surpass IE5 efficiency levels. These designs optimize system-wide pressure boosting efficiency and reduces energy costs.

Best efficiency staging, automatic set-point adjustment and integrated variable frequency drives provide even greater savings.

MINIMAL FOOTPRINT

Armstrong Design Envelope Boosters lead the industry with a compact package design that minimizes floor space requirements and simplifies on-site delivery.

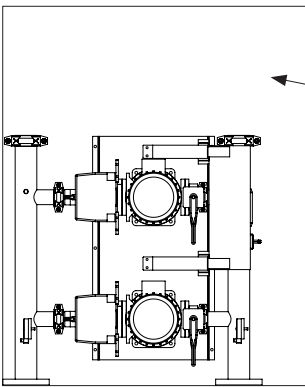

Competing Models

Design Envelope 6800Q* 68" x 40" Competing models 77" x 48"

SPACE SAVINGS OF 25%

* (including Permanent Magnet)

EASY BMS CONNECTIVITY

Supports leading communications protocols, including Modbus/BACnet MSTP/BACnet IP.

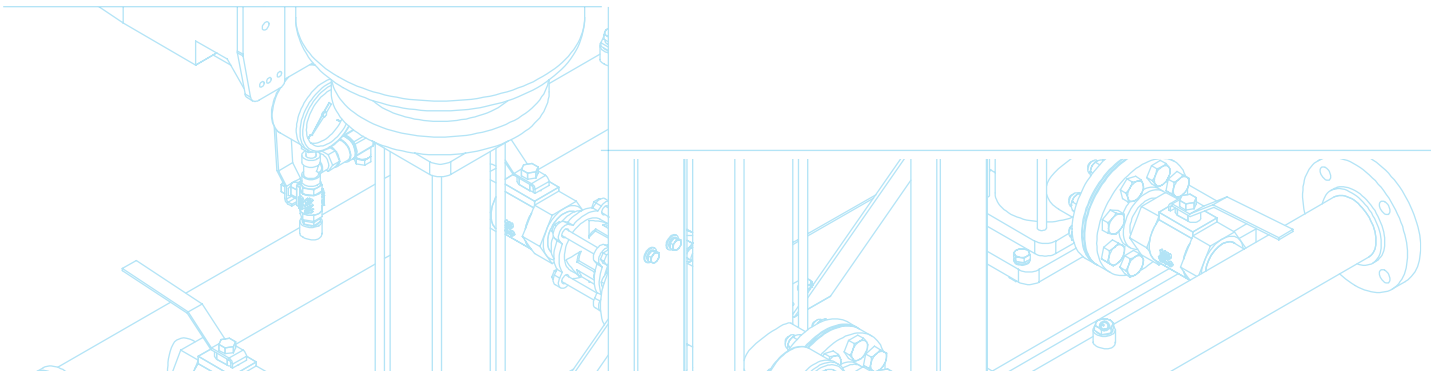

EASY SELECTION

Savings Calculator: New energy performance calculator delivers accurate savings projections.



Online selection software: ADEPT allows users to size booster systems and engage in collaborative system design.

Booster Upgrade Tool: Use readily available building information and flow demand history to size your booster. With proper sizing you can minimize footprint, reduce capital costs and reduce operating costs.

Visit Armstrongfluidtechnology.com/adept

EASY COMMISSIONING

With a simple step-by-step software wizard to guide the process, commissioning your booster is easy.

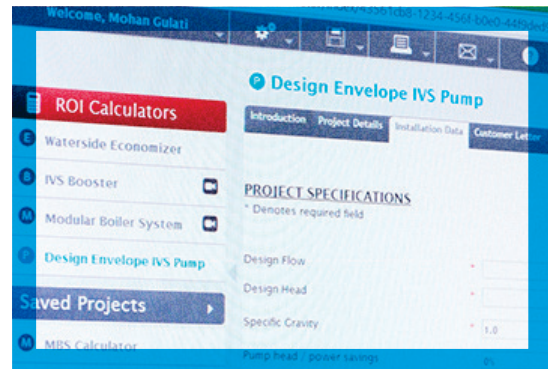

Interchangeable inlet sides: No matter how you configure the booster, addressing design changes doesn't require pipe re-work. You can easily re-orient the suction and discharge headers on site.

KEY FEATURES

Menu-driven setup screens support multiple languages.

Controller has a 4.3-inch color touchscreen and 128MB flash memory.

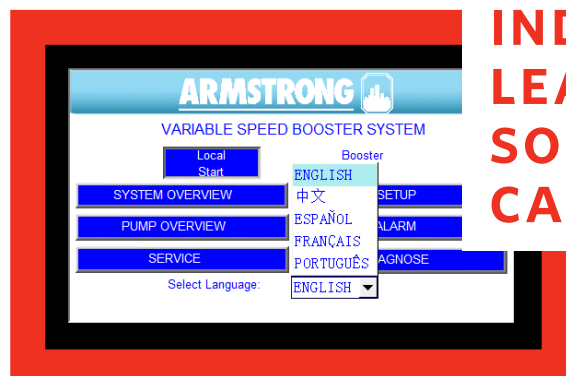

INDUSTRY-LEADING SOFTWARE CAPABILITIES

ENERGY AND WATER CONSUMPTION INSIGHTS

Armstrong Design Envelope Boosters provide detailed reports on operation.

Energy profiling capabilities include:

Monthly and annual energy consumption

Instantaneous kW readings

Reset of stored data

Energy cost reporting is based on programmable cost per kW values

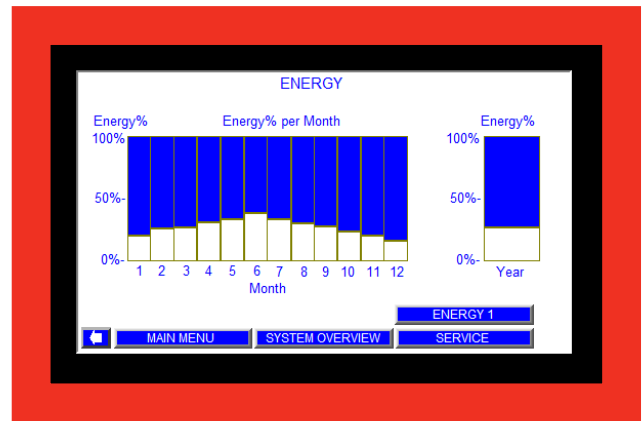

Flow analysis provides

Maximum flow

Current flow

Data charts

Detailed histogram illustrating water consumption patterns

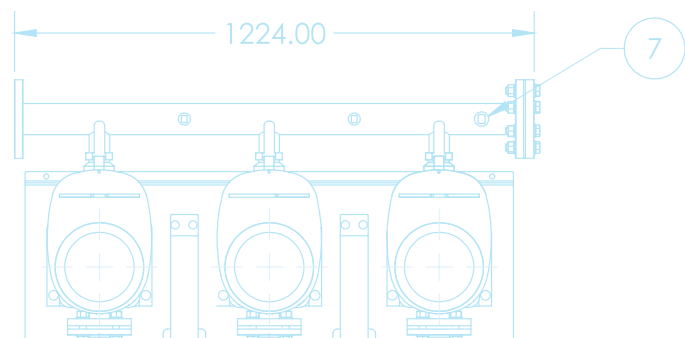
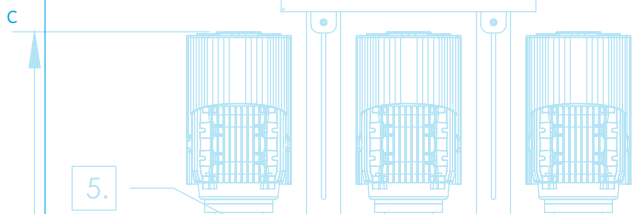
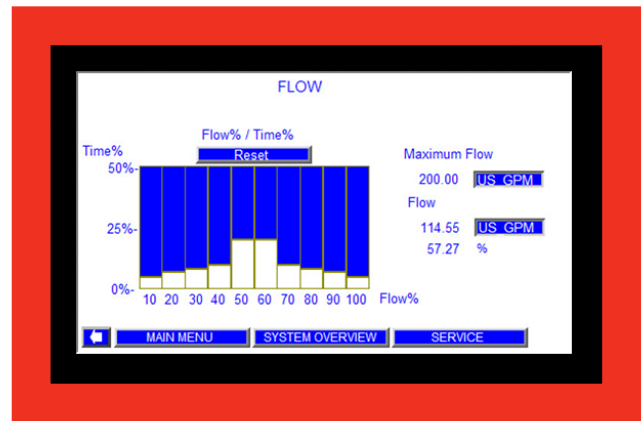

REAL-TIME PUMP DATA

Stores and presents performance data for individual pumps. Control software supports manual control of pump operations.

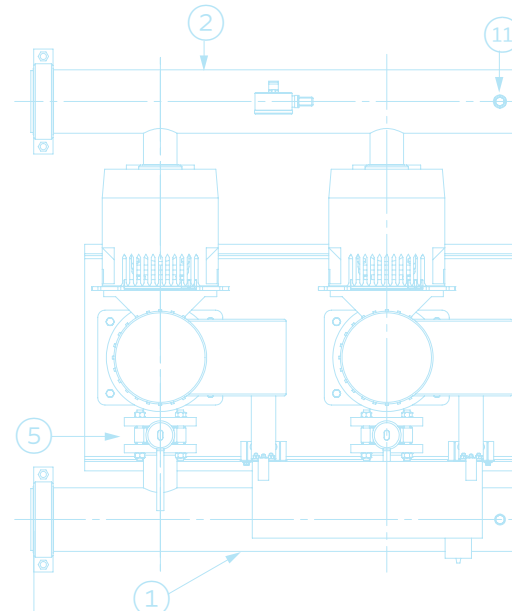
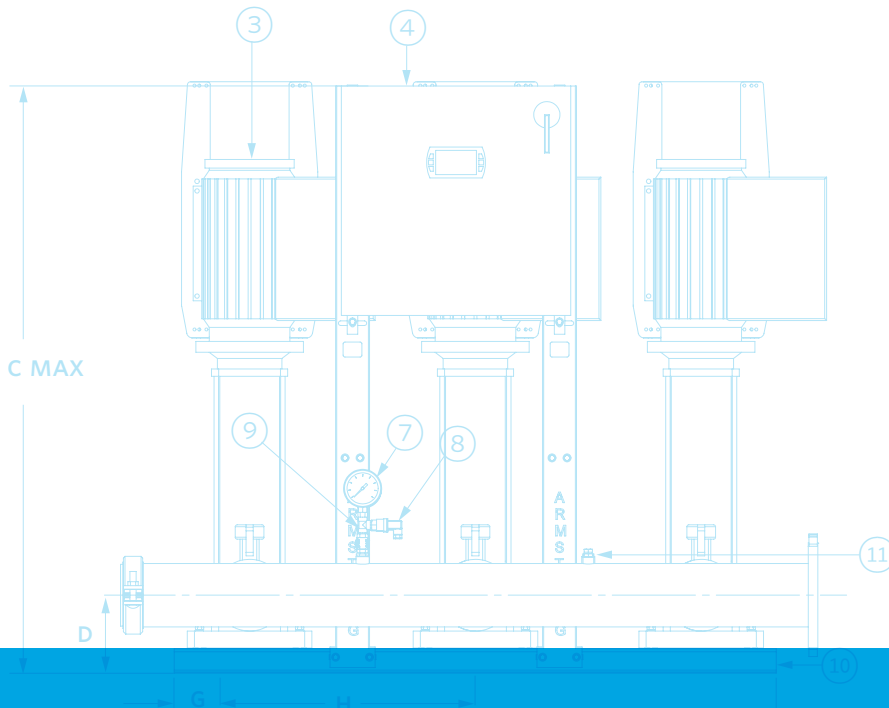
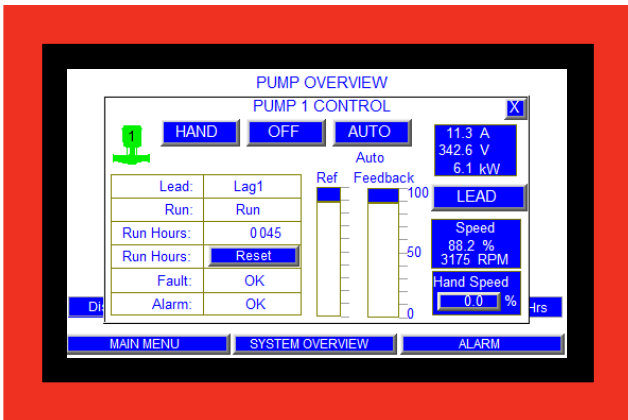

FULL COMPLIANCE WITH ASHRAE 90.1



FULLY COMPLIANT TO GLOBAL DRINKING WATER STANDARDS

No-flow shutdown

Senses when there is no demand in the system and shuts off the booster.

Pressure setback

Built-in logic provides feedback on flow and pressure drop during variable speed operation. This provides all the energy savings without the costs for installation and maintenance of remotely located pressure transducers.

Variable Speed Control Across Wide Operating Range

Design Envelope technology provides energy-efficient operation across a wide range of flow and pressure requirements. Demand for water pressure is met precisely and no energy is wasted on over-pumping.

Design Envelope boosters are constructed of high quality 304 stainless steel structural components making them a long lasting choice for both new and retrofit projects.

Pumps and manifolds are constructed of high grade 304 stainless steel. Drinking water is only in contact with the highest of material standards, ensuring the water delivered by the booster package meets the strictest health requirements.

SOFTFILL

Recharge the system with water after maintenance with no risk of damage to system components.

ALTERNATE SETPOINTS

Have a cooling tower running in the summer or heating boilers on your top floor? Easily select different setpoints for different seasons.

NO-FLOW PRESSURE OPTIMIZATION

Use smaller tanks to address the same demand by enabling 'Tank fill' mode to recharge your tank prior to shutdown.

BOOSTER APPLICATION RANGE

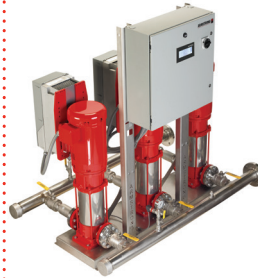

PERFORMANCE

DEPM 6800Q
2-5 PUMPS

DE 6800Q
2-5 PUMPS

DESCRIPTION

The leading solution in the industry

DEPM motors with Design Envelope technology maximize efficiency, reduce noise and ensure reliability

Excellent all-purpose solution for applications requiring higher flowrates and boost pressures

Multiple pump configurations ensure design flexibility and ease of install and commissioning

FLOW RATE	MAX L/s	170
BOOST PRESSURE	MAX m	245
TOTAL POWER	MAX kW	55

170
280
225

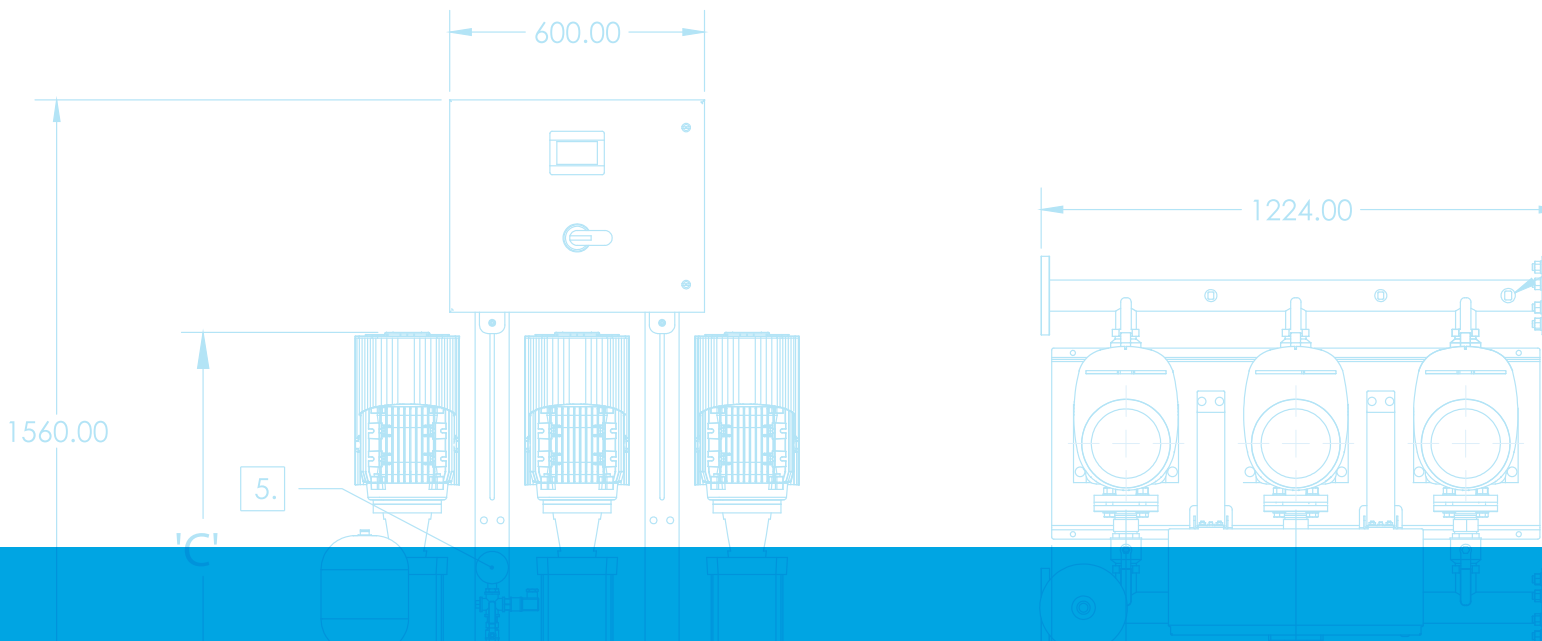

TORONTO

23 BERTRAND AVENUE,
TORONTO, ONTARIO,
CANADA, M1L 2P3
+1 416 755 2291

BUFFALO

93 EAST AVENUE, NORTH
TONAWANDA, NEW YORK,
U.S.A., 14120-6594
+1 716 693 8813

DROITWICH SPA

POINTON WAY, STONEBRIDGE CROSS
BUSINESS PARK, DROITWICH SPA,
WORCESTERSHIRE,
UNITED KINGDOM, WR9 0LW
+44 121 550 5333

MANCHESTER

WOLVERTON STREET, MANCHESTER
UNITED KINGDOM, M11 2ET
+44 161 223 2223

BANGALORE

#18, LEWIS WORKSPACE, 3RD FLOOR,
OFF MILLERS - NANDIDURGA ROAD,
JAYAMAHAL CBD, BENSON TOWN,
BANGALORE, INDIA 560 046
+91 80 4906 3555

SHANGHAI

UNIT 903, 888 NORTH SICHUAN RD.
HONGKOU DISTRICT, SHANGHAI
CHINA, 200085
+86 21 5237 0909

BEIJING

ROOM 1612, NANYIN BUILDING NO.2
NORTH EAST THRID RING ROAD
CHAOYANG DISTRICT, BEIJING,
CHINA 100027
+86 21 5237 0909

SÃO PAULO

RUA JOSÉ SEMIÃO RODRIGUES
AGOSTINHO, 1370 GALPÃO 6 EMBU
DAS ARTES, SAO PAULO, BRAZIL
+55 11 4785 1330

LYON

93 RUE DE LA VILLETTE
LYON, 69003 FRANCE
+33 4 20 10 26 21

DUBAI

JAFZA VIEW 19, OFFICE 402
P.O. BOX 18226 JAFZA,
DUBAI - UNITED ARAB EMIRATES
+971 4 887 6775

JIMBOLIA

STR CALEA MOTILOR NR. 2C
JIMBOLIA 305400, JUD.TIMIS
ROMANIA
+40 256 360 030

FRANKFURT

WESTERBACHSTRASSE 32,
D-61476 KRONBERG IM TAUNUS
GERMANY
+49 6173 999 77 55

For more information, contact your Armstrong
representative or visit us at:

ArmstrongFluidTechnology.com/ContactUs

ARMSTRONG FLUID TECHNOLOGY®
ESTABLISHED 1934

ARMSTRONGFLUIDTECHNOLOGY.COM

