

ARMSTRONG



VERTICAL IN-LINE Pumps

FILE NO:	2-1
DATE:	July 2010
SUPERSEDES:	2-1
DATE:	December 2004

Split Coupled Vertical In-Line pumps



The Armstrong 4300 Series has the greatest floor space savings result when Vertical In-Line pumps are installed with Suction Guides and Flo-Trex valves.

Equivalent base mounted horizontal split case pumps may take 3 times more floor space.

► Installation

Vertical In-Line pumps, being integral components of the pipework, eliminate need for inertia bases, inertia base springs, flexible pipe connectors, field grouting and alignment. Pipe hangers, sized for the weight of pump, piping and fittings, are the only supports required. Pipe stools, with vibration isolating pads, may be installed under each pipe leg.

► Maintenance

The mechanical seal is the critical service item in any pump. Removal of the 4300 Series split spacer coupling allows all mechanical seal components to be withdrawn for servicing, through the resulting space between pump and motor shafts, without disturbing other pump components or motor connection. Re-installing the rigid coupling brings the unit rotating assembly back to factory alignment specifications.

► Reliability

Dynamically balanced impeller, and shaft assembly rotating vertically on the 4300 Series centre-line means a quiet, long lasting pump with minimum vibration, as static shaft deflection is eliminated. There are no pump bearings to service in the Vertical In-Line design. The 4300 Series is a reliable, time-proven unit with less down time.

► Flexibility

Small footprint, low installation costs, reliable and easy to maintain. These features, combined with flow range in excess of 630 l/s (10,000 gpm), affirms the 4300 Series as the most flexible pump design available.

Life cycle value at every turn

► Design features

1. Metric IEC72 standard motor designed for Vertical In-Line operation
2. Heavy cylindrical bracket with 360° register on each flange provides a grid union of pump and motor
3. Motor shaft run-out limited to 0.025 mm (0.001") T.I.R. (Total Indicator Reading)
4. Axially split, spacer type rigid coupling permits seal maintenance without disturbing pump or motor.
Lightweight high tensile aluminum, precision bored and designed to reduce bearing load.
5. Shaft deflection at mechanical seal limited to 0.025 mm (0.002") T.I.R
6. Mechanical seal, accessible and easily replaceable (Outside multi-spring balanced mechanical seal illustrated. See page 5 for mechanical seal options)
7. Gland plate with flush connection ensures liquid at seal faces and positive venting of seal chamber
8. Dynamically balanced impeller assures smooth vibration-free operation
9. Radially split volute with equal suction and discharge flange sizes. Separate drilled and tapped openings for gauge, flush and drain connections
10. Liberal inlet passageways and straightening vanes provide optimum suction performance and quiet operation
11. Ribs cast integral with volute. Machined surface to accept floor support when specified
12. Confined casing gasket to meet stringent industrial temperature and pressure applications
13. Coupling guard fully encloses access openings (Not shown)

► Single Suction

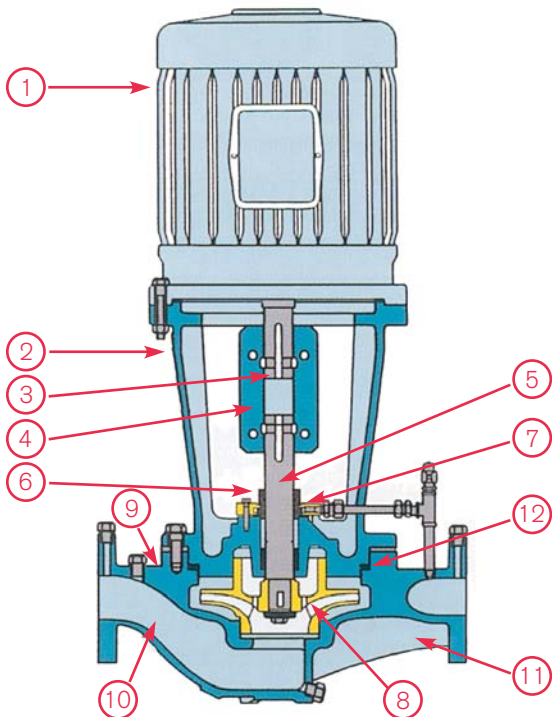

► Double Suction

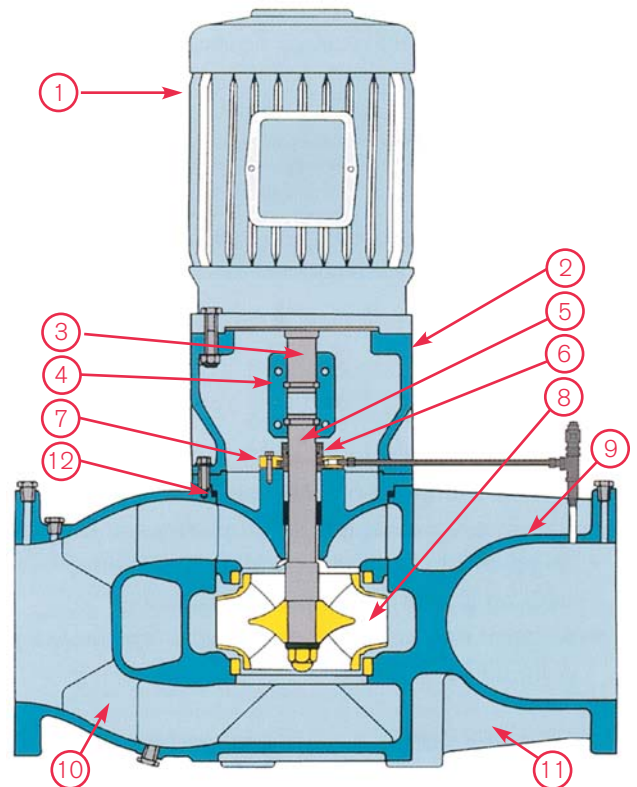

► Split Coupled

The auxiliary split, spacer type rigid coupling permits seal maintenance without disturbing the pump or motor connections. The mechanical seal is accessible and easily replaced. (Outside multi-spring balanced mechanical seal is illustrated)



1) Split coupling with outside seal. Auxially split coupling shown with coupling guard removed. Coupling bolts are still in place. Rotating element of seal is seen below the coupling, above gland plate.



2) Remove the coupling bolts. The coupling halves (with drive and annular positioning keys) are taken from motor and pump shafts. Loosen set screws on seal rotating element and slide from pump shaft. (For inside seal see step (3))



3) Disconnect seal flush line and remove gland plate bolts. The gland plate and seal seat may then be taken out between the space in the shafts. With inside seal the complete seal is removed following the gland plate.



4) New seal may now be installed. Reverse the procedure: Install new seal, replace gland plate, replace coupling and restart pump. Rigid coupling retains factory alignment.

► Material of Construction

Pump Series	Construction	Volute	Gasket	Impeller	Capscrew	Washer	Acorn Nut	Adapter Cover	Adapter Bracket	Stuffing Box Cover	Pump Shaft	Coupling	Gland Plate
4300	BF	CI	F	BZ	S	SS-3	BR-2	CI	CI	CI	SS-6	AL	BR-2
	AI	CI	F	CI	S	SS-3	S	CI	CI	CI	SS-6	AL	SS-4
	AB	BZ	F	BZ	SS-5	SS-5	BR-2	BZ	CI	CI	SS-6	AL	BR-2
	DI	DI	F	CI	S	SS-3	S	DI	DI	BZ	SS-6	AL	SS-4
	DBF	DI	F	BZ	S	SS-3	BR-2	DI	DI	DI	SS-6	AL	BR-2

► Material Construction Code

- AB - All Bronze
- AI - All Iron
- BF - Iron Body, Bronze Fitted
- DI - Ductile Iron
- DBF - Ductile Iron, Bronze Fitted
- AL - High Tensile Aluminum Bar
- BZ - Cast Bronze ASTM B584
grade C84400
- CI - Cast Iron ASTM A48 class 30
- DI - Cast Ductile Iron ASTM A536
grade 65-45-12
- F - Fibre
- N - Neoprene
- S - Steel
- BR-1 - Hard brass tubing ASTM B111
- BR-2 - Brass Bar ASTM B16
- SS-2 - Stainless Steel ASTM F593 Alloy group 2
- SS-3 - Stainless Steel ASTM A276 type 303
- SS-4 - Stainless Steel ASTM A276 type 304
- SS-5 - Stainless steel ASTM A276 type 316
- SS-6 - Stainless Steel ASTM A276 type 416

► Pressure / Temperature Chart

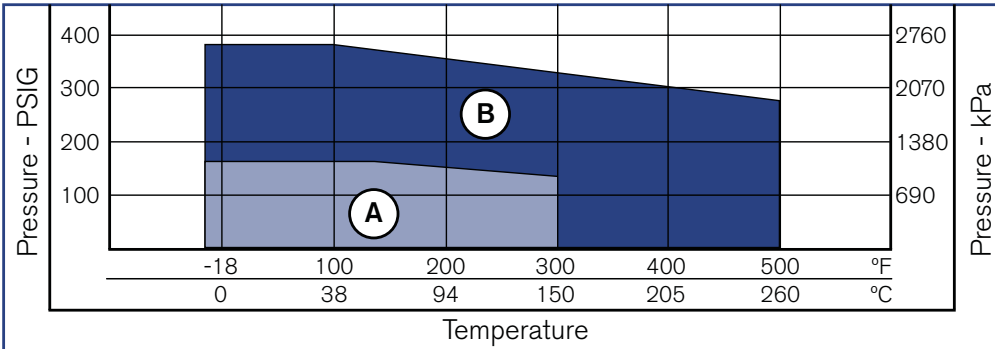

A - 125 lb. Cast Iron/
Cast Bronze
B - 250 lb. Ductile Iron

Note: Refer to Armstrong for mechanical seal pressure/temperature limitations.

► Sealing Arrangements

Armstrong 4300 Series split coupled Vertical In-Line pumps are available with two mechanical seal arrangements. Both can be removed easily and quickly for servicing without costly removal of the motor or pump from the piping. The high performance outside type mechanical seal combines the advantages of a multi-spring balanced seal with premium quality and is the easiest to remove. The inside type mechanical seal provides an economical alternative.

OUTSIDE BALANCED MECHANICAL SEAL ARRANGEMENT

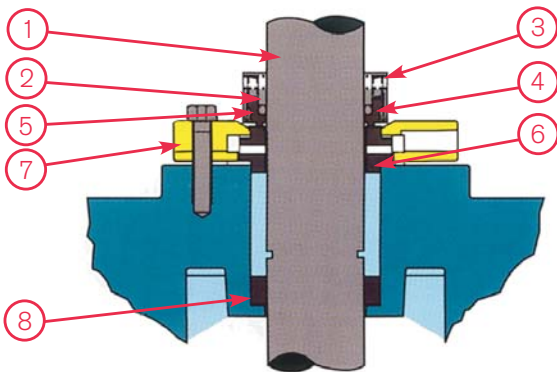

- 1 Pump Shaft
- 2 Rotating Hardware
- 3 Spring(s)
- 4 Secondary Seal
- 5 Rotating Face
- 6 Stationary Seat
- 7 Gland Plate
- 8 Throttle Bushing

INSIDE UNBALANCED MECHANICAL SEAL ARRANGEMENT

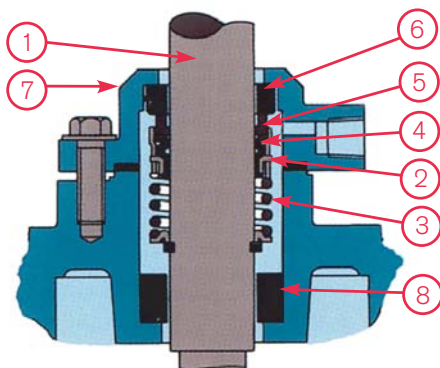

- 1 Pump Shaft
- 2 Rotating Hardware
- 3 Spring(s)
- 4 Secondary Seal
- 5 Rotating Face
- 6 Stationary Seat
- 7 Gland Plate
- 8 Throttle Bushing

► The Armstrong System

Armstrong Vertical In-Line pumps, when installed with Armstrong Suction Guides and Armstrong Flo-Trex combination valves, result in greater added value and lower life cycle costs.

The Armstrong Suction Guide, designed with flow stabilizing plates in the outlet port, allows the guide to be bolted directly onto the pump suction flange, enabling the vertical piping to turn 90° into the pump. A disposable fine mesh start-up strainer and permanent perforated stainless steel strainer complete this valuable fitting.

The Suction Guide eliminates the need for a separate suction strainer, long radius elbow and minimum straight pipe run to the pump suction.

The Armstrong Flo-Trex triple function combination valve is designed to operate equally as a non-slam check valve, a drip-tight isolation valve and a properly designed throttling valve. The Armstrong uniquely designed valve is field convertible from 90° angle type to 180° straight type.

The Flo-Trex combination valve eliminates the need for a discharge elbow, a separate check valve and a throttling type isolation valve. For information on Flo-Trex valves and Suction Guides please refer to leaflet 6-1 in the catalogue.

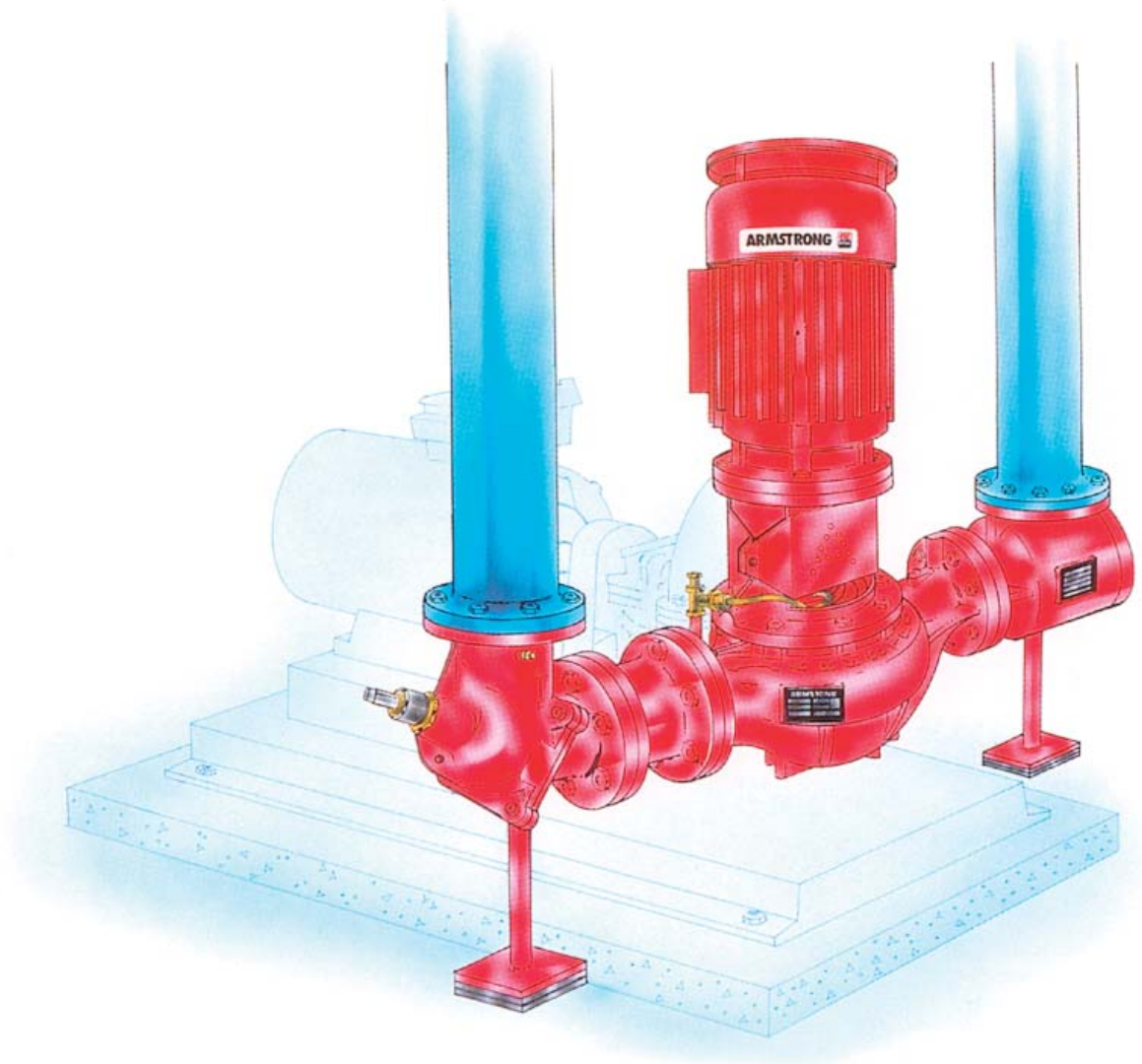

Typical Specifications

4300 Series Vertical in-Line centrifugal Pumps

► 1.0 Pumps - Vertical in-Line centrifugal

- 1.1 Provide Armstrong Vertical In-Line pumps, single stage, single or double suction type, with pump characteristics which provide rising heads to shut off. Refer to pump schedule for pump flows, heads, motor speed, enclosure, efficiency and power requirements.
- 1.2 Pumps shall be 4300 Series split coupled type, with rigid spacer type coupling.

► Pump Construction

1. Pump Casing - Cast Iron for working pressure below 12.05 bar at 65°C (PN16 flange rating) and Ductile Iron for working pressures to 25 bar at 65°C (PN25 flange rating).
Suction and discharge connections shall be flanged and the same size and shall be drilled and tapped for seal flush and gauge connections
2. Impeller - Bronze, fully enclosed type. Dynamically balanced.
3. Shaft - Provide Stainless Steel pump shaft
4. Coupling - Rigid spacer type of high tensile aluminum alloy. Couplings shall be split to allow removal from pump and motor shafts, leaving space between the shafts sufficient to replace all mechanical seal components without disturbing the pump or motor.
5. Mechanical Seals - Shall be Stainless Steel outside multi-spring balanced type with Viton secondary seal. Provide bronze gland plate with Stainless Steel hardware. provide factory installed flush line with manual vent.
6. All split coupled pumps shall be provided with a lower seal chamber throttle bushing.
7. Motor Horsepower - Shown on the schedule are minimum and have been sized for continuous operation without exceeding full load nameplate rating, exclusive of service factor.

► Seal flush line fittings, if required

Supply in the flush line to the mechanical seal a 50 micron cartridge filter and sight flow indicator, to suit the working pressure encountered.

Filters shall be changed, by the installing contractor, after system is flushed and on a regular basis until turned over to the owner.

Alternately, for pumps with differential pressures exceeding 200 kPa:

Supply in the flush line to the mechanical seal a cyclone type separator, with sight flow indicator.

Our policy is one of continuous improvement and we reserve the right to alter our dimensions and specifications without notice

Armstrong Integrated Limited
Wenlock Way
Manchester
United Kingdom, M12 5JL
T: +44 (0) 8444 145 145
F: +44 (0) 8444 145 146

S. A. Armstrong Limited
23 Bertrand Avenue
Toronto, Ontario
Canada, M1L 2P3
T: 001 416 755 2291
F: 001 416 759 9101

