

PUMP SIZE	MOTOR KW	FLC AMPS	PUMP WEIGHT KGS	SET WEIGHT KGS	VESSEL SIZE LTRS	WORKING PRESSURE MAX BAR	TEST PRESSURE MAX BAR	STARTING CURRENT	L MM
SV6601-1	4	8.5	89	395	60	2.4	24	20	926

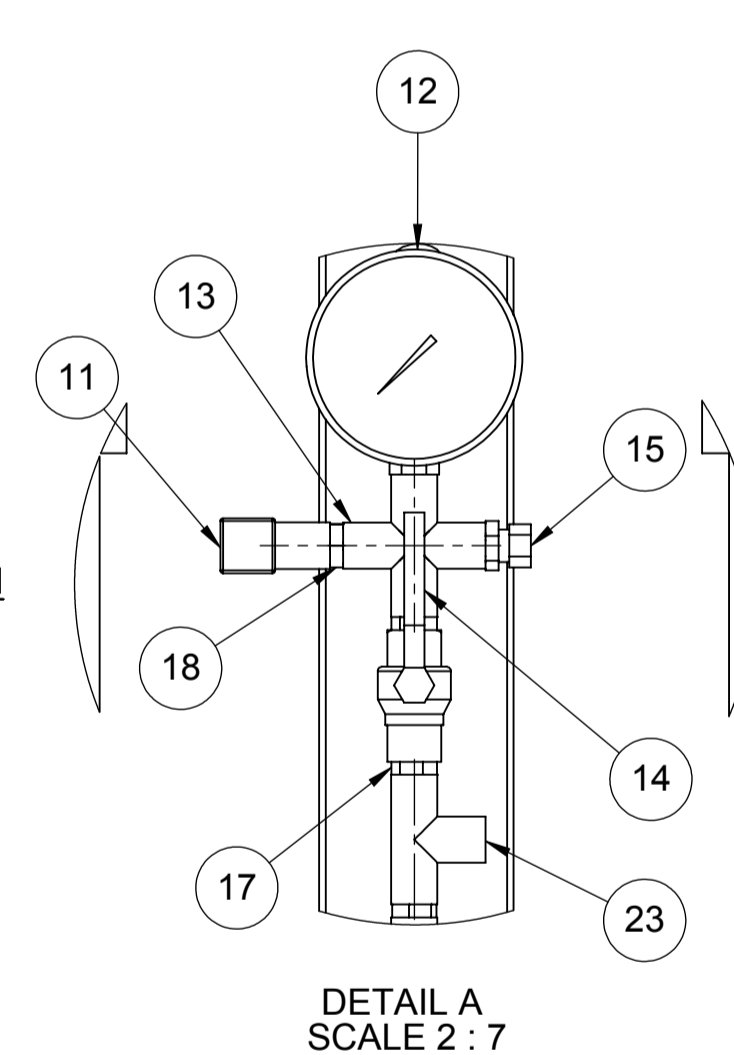

ANTI-VIBRATION MOUNTINGS OPTIONAL ONLY SUPPLIED WHEN ORDERED (6-PER SET K2092/10)

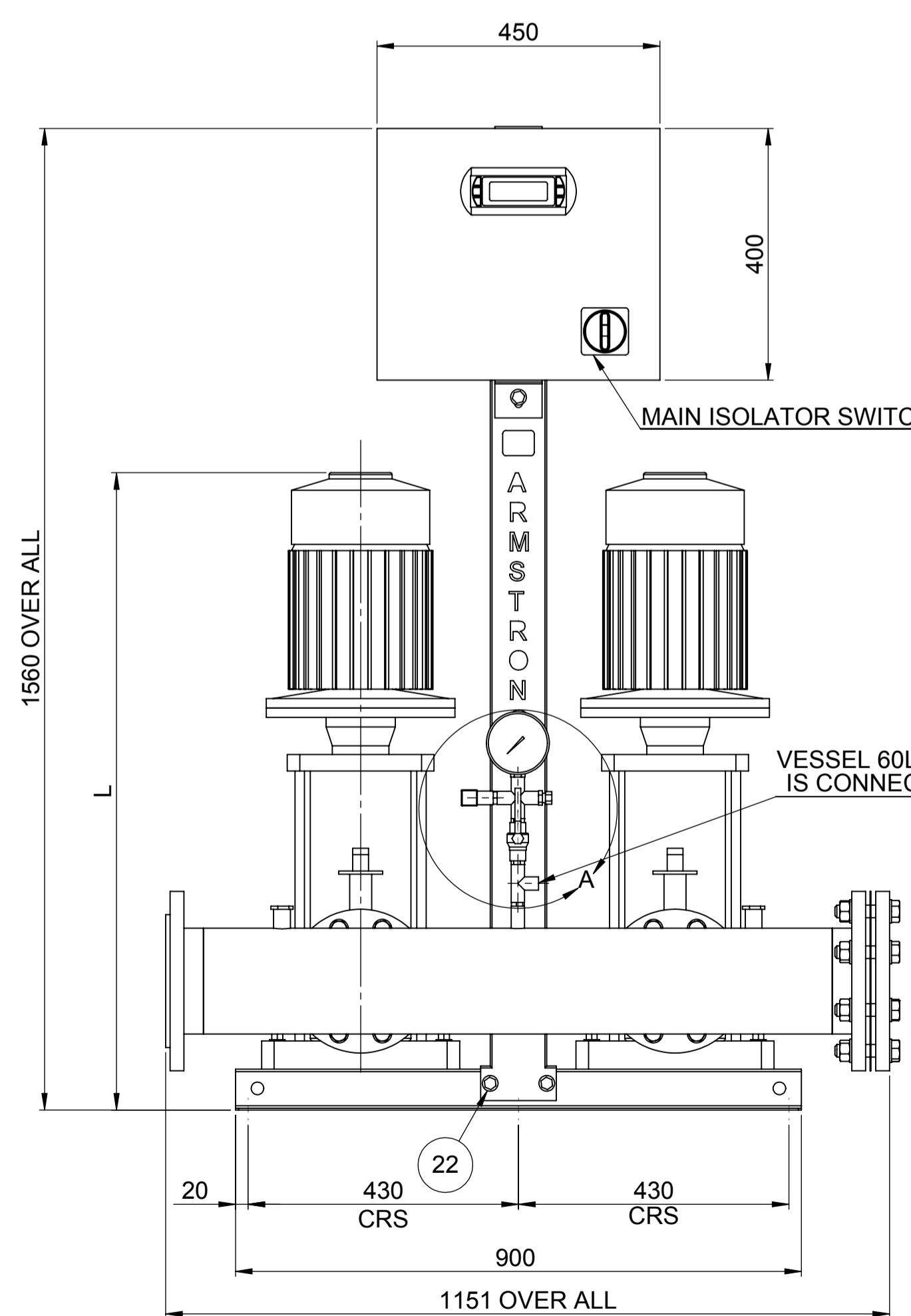
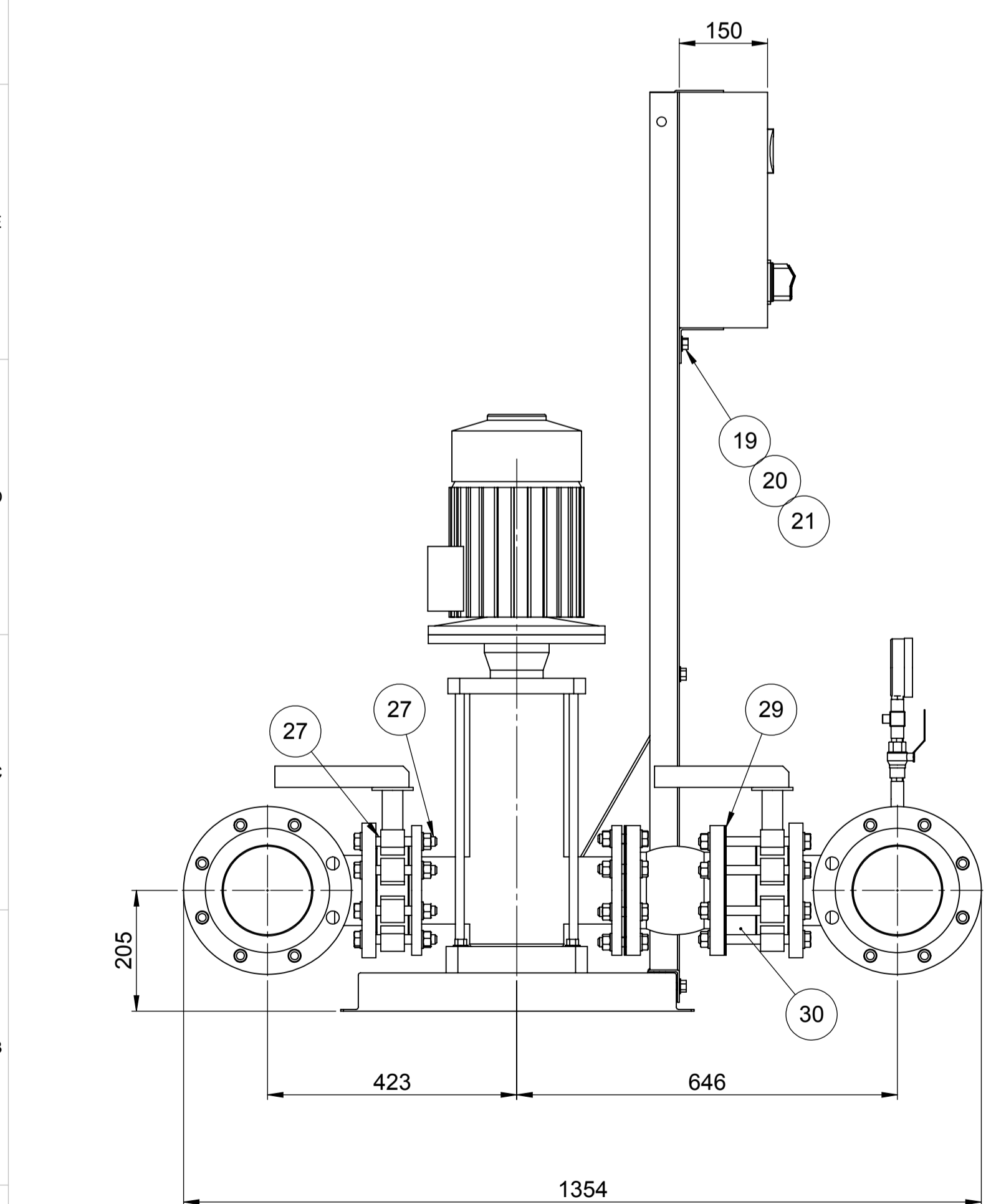
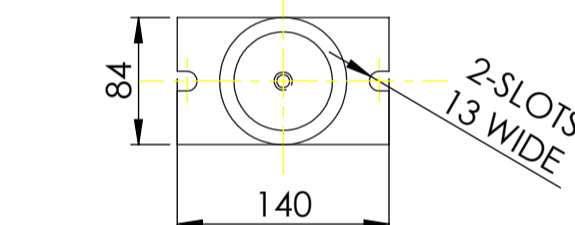

FLEXIBLE CONNECTORS OPTIONAL ONLY SUPPLIED WHEN ORDERED (2-PER SHEET)

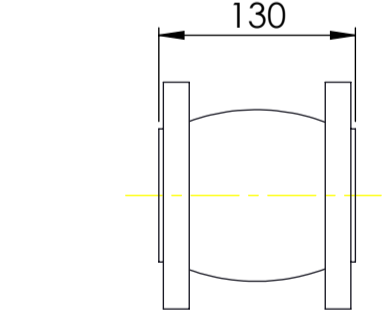

NOTE:-

- 1) MAIN POWER SUPPLY TO PANEL MUST BE SIZED TO COVER ALL PUMPS RUNNING AT THE SAME TIME
- 2) LARGE STORAGE VESSELS, IF ORDERED, WILL BE SUPPLIED LOOSE FOR POSITIONING FOR CLIENT TO SUIT THE AVAILABLE FLOOR SPACE. CLIENT IS TO PROVIDE A CONNECTION FROM THE VESSEL TO THE DELIVERY PIPEWORK ADJACENT TO THE SET ISOLATING AND DRAIN VALVES SHOULD BE FITTED IN THIS CONNECTION
- 3) 60 Lt TANK WILL BE SUPPLIED LOOSE AND SHOULD BE ASSEMBLED ON SITE
- 4) FLANGES ARE AVAILABLE BOTH IN 16 & 25 BAR VERSION
- 5) FOR STANCHION SELECTION USE DRAWING NO. PK14967

ITEM NO	DESCRIPTION	NO. OFF
1	BASE PLATE	1
2	BOLT - M12	8
3	WASHER - M12	8
4	CAGE NUT - M12	8
5	VMS PUMP	2
6	SUCTION/DISCHARGE MANIFOLD ASSY	2
7	ISOLATING VALVE 4"	4
8	NRV 4"	2
9	SUPPORT RIB	1
10	STANCHION	1
11	PRESSURE TRANSDUCER	1
12	PRESSURE GAUGE	1
13	FEMALE CROSS 1/2"	1
14	ISOLATING VALVE 1/2"	1
15	AIR VENT 1/4"	1
16	CONTROL PANEL	1
17	1/2" NIPPLE	3
18	1/2" x 1/4" REDUCING BUSH	3
19	BOLT - M10	9
20	WASHER - M10	9
21	NUT - M10	3
22	CAGE NUT - M10	6
23	1/2" T	1
FASTENERS FOR PN16		
24	STUD - M16x79	16
25	WASHER - M16	96
26	NUT - M16	96
27	STUD - M16x54	48
28	STUD - M16x109	16
FASTENERS FOR PN25		
24	STUD - M20x90	16
25	WASHER - M20	96
26	NUT - M20	96
27	STUD - M20x60	48
28	STUD - M20x130	16
29	GASKET - 100NB	4
30	SPACER PIECE - 100NB	2

PART No. _____ JOB No. _____ DESIGN No. _____ PATTERN No. _____ FILE NAME _____ FINISH _____		UNLESS OTHERWISE SPECIFIED: DIMENSIONS ARE IN MM WELD SYMBOLS TO BS 499 SURFACE FINISH SHOWN IN UTM MACHINE WHERE SHOWN TO TOLERANCE ± 0.3 DIMENSIONING AND TOLERANCING PER BS 308 MATERIAL SPEC: _____ DRAWING RELEASE LEVEL: _____		NAME: PRAKASH DATE: 01/03/08 DRAWN: _____ CHECKED: _____ Q.A. _____ MFG APPR. _____ ENG APPR. _____ COMMENTS: _____		TITLE: <b>6800 HMP SERIES 2PUMP SV66</b> SIZE: A1 DRG. NO.: PX10764 SCALE: 1:8 WEIGHT: KG SHEET 1 OF 1		REV: _____ DATE: _____ DRN BY: _____ CHECKED BY: _____ APP. BY: _____		PROPRIETARY AND CONFIDENTIAL THIS DRAWING IS THE PRIVATE AND CONFIDENTIAL PROPERTY OF ARMSTRONG. ALL COPYRIGHT, MANUFACTURING AND SALES RIGHTS RESERVED.		ARMSTRONG DO NOT SCALE	
---	--	---	--	--	--	---	--	---	--	---	--	---------------------------	--