

ALL FLANGES TO BS4504
 MAX WORKING PRESSURE
 TEST PRESSURE

16BAR
 15BAR
 22.5BAR

UNCONTROLLED

PUMP SIZE	MOTOR KW	FLC AMPS 3x415V	PUMP WEIGHT KGS	SET WEIGHT KGS
402T03T	0.37	1.33	17.5	169
403T05T	0.55	1.43	18.5	171
404T07T	0.75	2.02	21.0	176
405T11T	1.10	2.61	22.0	178
406T11T	1.10	2.61	22.5	179
407T11T	1.10	2.61	23.0	180
408T15T	1.50	3.45	29.5	193
409T15T	1.50	3.45	30.0	194
411T22T	2.20	5.03	32.0	198
413T22T	2.20	5.03	33.0	200
414T30T	3.00	6.22	39.0	212

ANTI-VIBRATION MOUNTINGS OPTIONAL ONLY SUPPLIER WHEN ORDERED (4-PER SET K2092/1)

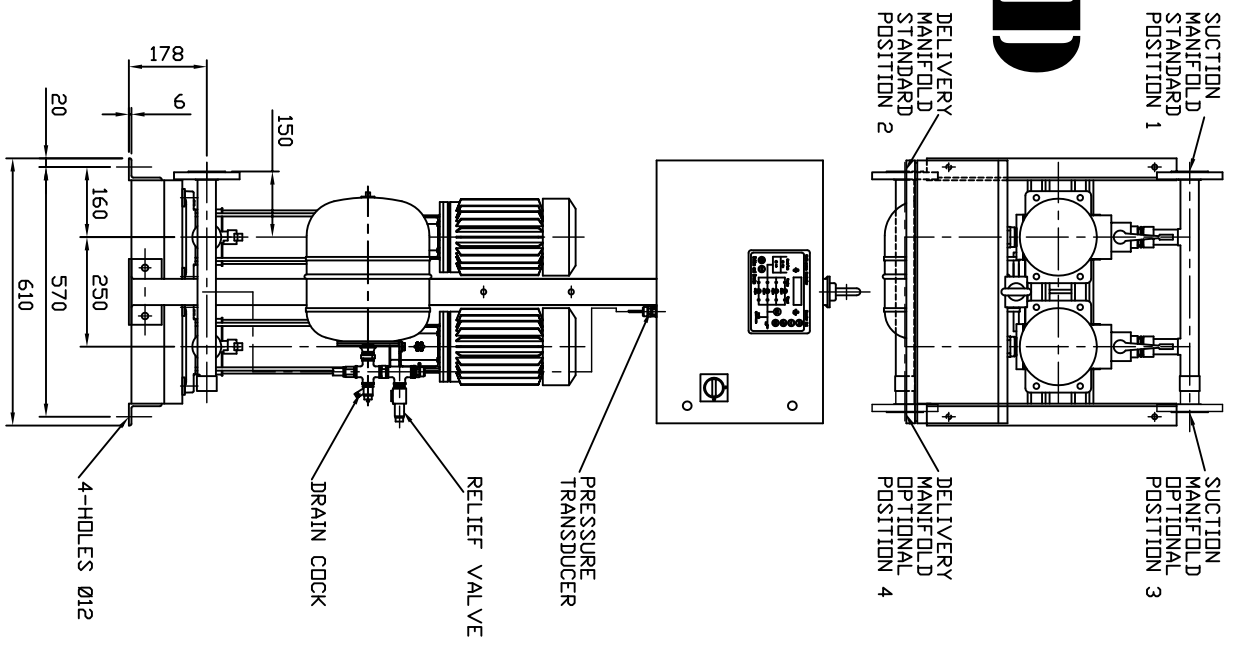
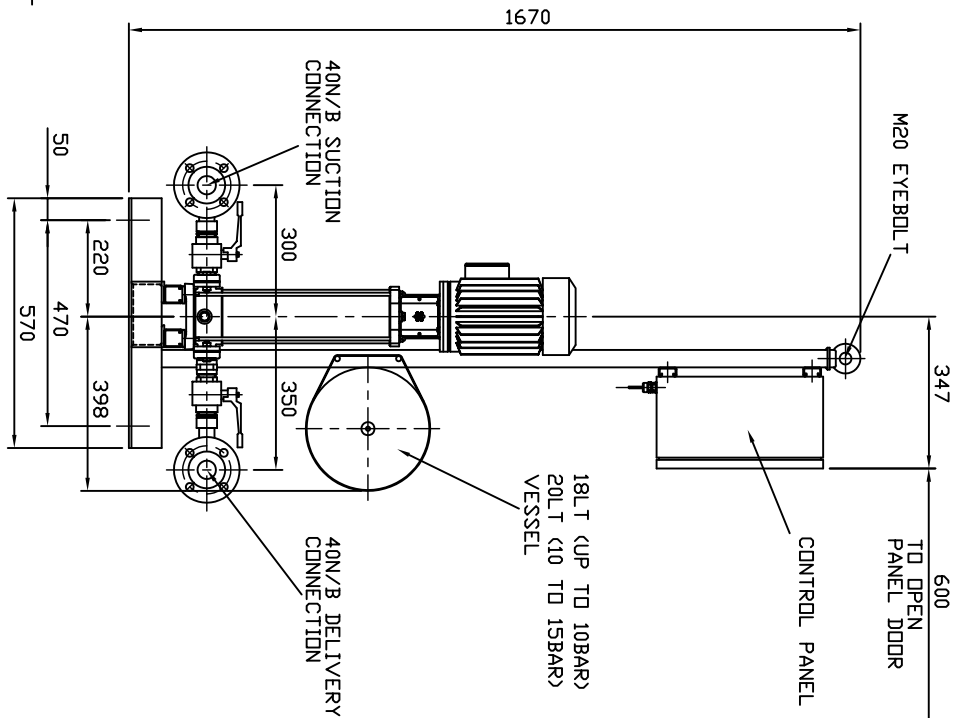

NOTE :-

- 1) MAIN POWER SUPPLY TO PANEL MUST BE SIZED TO COVER ALL PUMP RUNNING AT SAME TIME
- 2) LARGE STORAGE VESSELS, IF ORDERED, WILL BE SUPPLIED LOOSE FOR POSITIONING BY CLIENT TO SUIT THE AVAILABLE FLOOR SPACE. CLIENT IS TO PROVIDE A CONNECTION FROM THE VESSEL TO THE DELIVERY PIPEWORK ADJACENT TO THE SET ISOLATING AND DRAIN VALVES SHOULD BE FITTED IN THIS CONNECTION

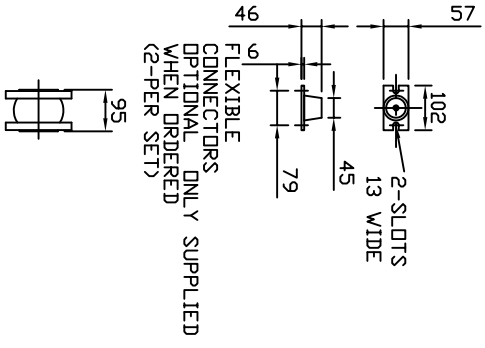

LAST MODIFICATION DETAILS

DRAWING BORDER CHANGED	ALL DIMENSIONS IN mm DRAWN TO BS308 WELDING SYMBOLS TO BS499 SURFACE FINISH SHOWN IN MICRO METERS MACHINE WHERE SHOWN TO TOLERANCE ± 0.3MM UNLESS OTHERWISE STATED
ISSUE 4	DATE 15/02/2006 DRN PJB APP PJB

JOB No.	PART No.	WEIGHT KG	FILE NAME
-	-	-	PX10277-4
DESIGN No.	PATTERN No.	MATERIAL	MATL SPEC.
-	-	-	-

TITLE
 GENERAL ARRANGEMENT
 HYDRPAK HML2 SET
 4-PUMP MODELS

DRG No.	PX10277-4
DATE 02/10/2002	DRN BSD
CHK EGU	APP EGU
SCALE NTS	SHEET 1 OF 1

ARMSTRONG HOLDEN BROOKE PULLEN

VENLOCK WAY, MANCHESTER, M12 5JL
 TEL: +44 (0) 161 223 2223