

| PUMP SIZE | MOTOR KW | FLC AMPS 3x415V | PUMP WEIGHT KGS | SET WEIGHT KGS | VESSEL SIZE LITRES | WORKING PRESSURE BAR | TEST PRESSURE BAR |
|-----------|----------|-----------------|-----------------|----------------|--------------------|----------------------|-------------------|
| 402105T | 0.55 | 1.43 | 17.5 | 39.0 | 60 | 10 | 15.0 |
| 403105T | 0.55 | 1.43 | 18.5 | 39.5 | 60 | 10 | 15.0 |
| 404107T | 0.75 | 2.02 | 21.0 | 40.7 | 60 | 10 | 15.0 |
| 405111T | 1.10 | 2.61 | 22.0 | 41.2 | 60 | 10 | 15.0 |
| 406111T | 1.10 | 2.61 | 22.5 | 41.5 | 60 | 10 | 15.0 |
| 407111T | 1.10 | 2.61 | 23.0 | 41.7 | 60 | 10 | 15.0 |
| 408115T | 1.50 | 3.45 | 29.5 | 45.0 | 60 | 10 | 15.0 |
| 409115T | 1.50 | 3.45 | 30.0 | 45.2 | 60 | 10 | 15.0 |
| 411122T | 2.20 | 5.03 | 32.0 | 46.2 | 20 | 15 | 22.5 |
| 413122T | 3.00 | 5.03 | 33.0 | 46.7 | 20 | 15 | 22.5 |
| 414130T | 3.00 | 6.22 | 39.0 | 49.7 | 20 | 15 | 22.5 |

ANTI-VIBRATION MOUNTINGS OPTIONAL, ONLY SUPPLIER WHEN ORDERED (4-PER SET KE2092/1)

FLEXIBLE CONNECTORS OPTIONAL, ONLY SUPPLIED WHEN ORDERED (2-PER SET)

NOTE :-

- 1) MAIN POWER SUPPLY TO PANEL MUST BE SIZED TO COVER ALL PUMP RUNNING AT SAME TIME
- 2) LARGE STORAGE VESSELS, IF ORDERED, WILL BE SUPPLIED LOOSE FOR POSITIONING BY CLIENT TO SUIT THE AVAILABLE FLOOR SPACE. CLIENT IS TO PROVIDE A CONNECTION FROM THE VESSEL TO THE DELIVERY PIPEWORK ADJACENT TO THE SET ISOLATING AND DRAIN VALVES SHOULD BE FITTED IN THIS CONNECTION

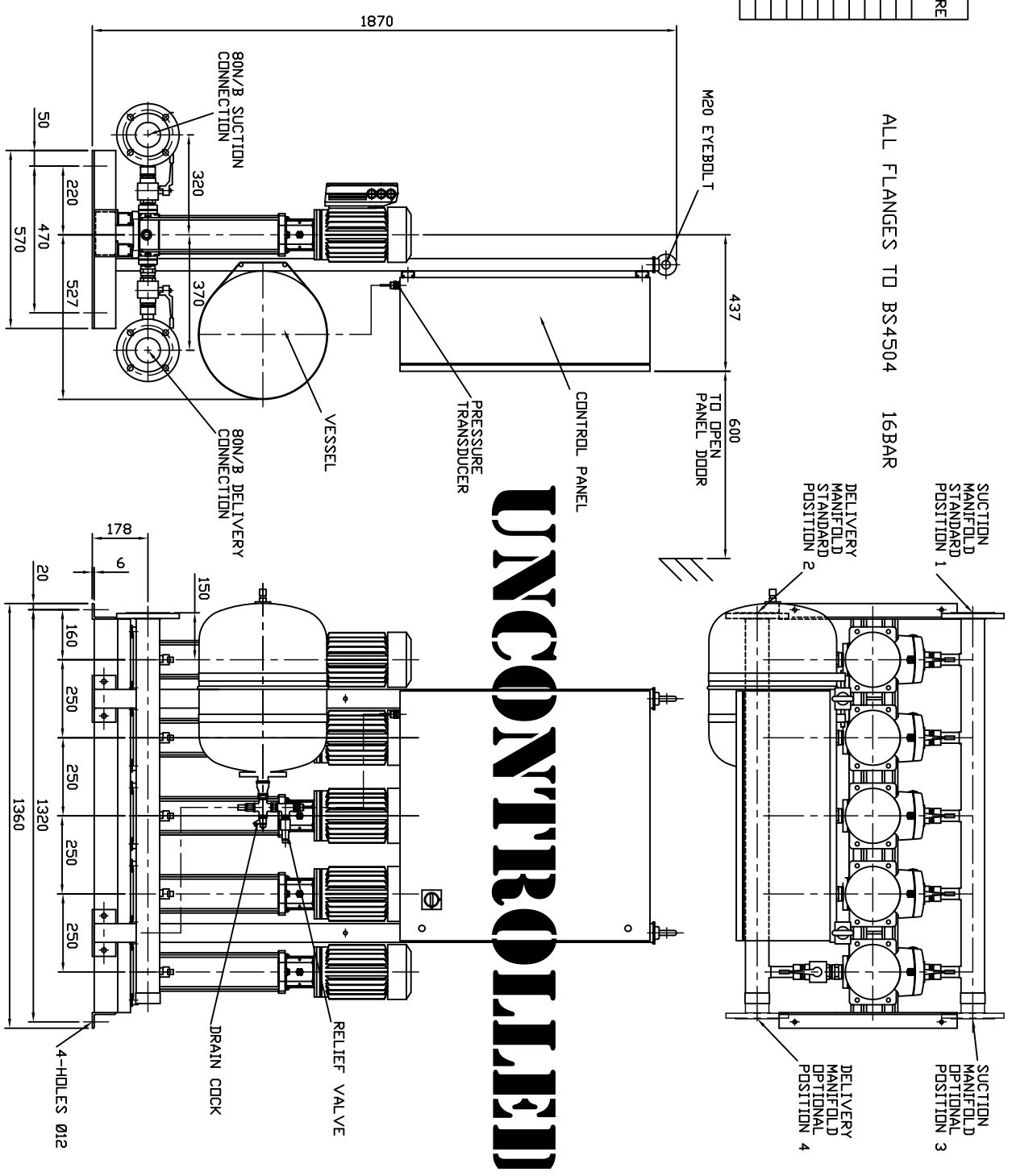

UNCONTROLLED

| | | | | | | | | | |
|---------------------------|--|----------------|--|--------------------------|--|--|--|--|--|
| LAST MODIFICATION DETAILS | | JOB No. - | | PART No. - | | WEIGHT KG - | | FILE NAME - | |
| DRAWING BORDER CHANGED | | DESIGN No. - | | PATTERN No. - | | MATERIAL - | | MAT'L SPEC. - | |
| ALL DIMENSIONS IN mm | | DRAWN TO BS308 | | WELDING SYMBOLS TO BS499 | | SURFACE FINISH SHOWN IN MICROMETERS | | MACHINE WHERE SHOWN V TO TOLERANCE ± 0.3MM UNLESS OTHERWISE STATED | |
| DATE: 15/02/2006 | | DRN: PJB | | APP: PJB | | TITLE: GENERAL ARRANGEMENT HYDROPAK IVSLS SET 4-PUMP MODELS C/W VLT8000 AQUA CONTROL | | DRG No. PX10468-1 | |
| DATE: 19/08/2004 | | DRN: BSD | | APP: EGU | | VENLOCK WAY, MANCHESTER, M12 5JL | | SHEET 1 OF 1 | |



ISSUE 1
 DATE: 15/02/2006
 DRN: PJB
 APP: PJB
 VENLOCK WAY, MANCHESTER, M12 5JL
 TEL: +44 (0) 161 223 2223