

SERIES 4030 | END SUCTION BASE MOUNTED SPLIT COUPLED | 6 × 5 × 11.5 | SUBMITTAL

File No: 40.70
Date: NOV. 26, 2014
Supersedes: 40.70
Date: OCT. 15, 2013

Job: _____ Representative: _____
 _____ Order no.: _____ Date: _____
 Engineer: _____ Submitted by: _____ Date: _____
 Contractor: _____ Approved by: _____ Date: _____

PUMP DESIGN DATA

No. of pumps: _____ Tag: _____
 Capacity: _____ USgpm (L/s) Head: _____ ft (m)
 Liquid: _____ Viscosity: _____
 Temperature: _____ °F (°C) Specific gravity: _____
 Suction: 6" (150mm) Flanged
 Discharge: 5" (125mm) Flanged

MATERIALS OF CONSTRUCTION

ANSI FLANGE RATING	ANSI 125	ANSI 250
Construction	<input type="checkbox"/> BF	<input type="checkbox"/> DBF
Casing	Cast iron	Ductile iron

Impeller: Bronze
Gasket: Confined non-asbestos fiber
Bearing frame: Cast iron
Anti-friction bearings: Permanently lubricated
Shaft: Carbon steel
Shaft sleeve: Stainless steel
Coupler: Constant speed: Woods sure-flex or equal
 Variable speed: Woods dura-flex or equal
Coupler guard: Steel OSHA
Baseplate: Fabricated steel

MECHANICAL SEAL DATA

Seal type: 2A **Stationary seat:** Silicone carbide
Secondary seal: EPDM **Rotating hardware:** Stainless steel
Spring: Stainless steel

MOTOR DESIGN DATA

HP: _____ RPM: _____ Frame size: _____ Enclosure: _____
 Volts: _____ Hertz: 60 Hz Phase: 3
 Efficiency*: NEMA premium 12.12 Other _____ %

* Fractional power and frame 56 motors are supplied with the standard efficiency of the manufacturer.

MAXIMUM PUMP OPERATING CONDITIONS

ANSI 125

175 psig at 150°F (12 bars at 65°C)
 140 psig at 250°F (10 bars at 121°C)

ANSI 250

300 psig at 150°F (20 bars at 65°C)
 250 psig at 250°F (17 bars at 121°C)

- Tolerance of ±0.125" (±3 mm) should be used
- See performance curves on page 3
- For exact installation, data please write factory for certified dimensions
- Pump equipped with casing drain plug and ¼" NPT suction and discharge gauge ports

OPTIONAL EQUIPMENT

FLUID TYPE	ALL GLYCOLS > 30% WT CONC		ALL OTHER NON-POTABLE FLUIDS		POTABLE (DRINKING) WATER	
	up to 200°F (93°C)	over 200°F (93°C)	up to 200°F (93°C)	over 200°F (93°C)	up to 200°F (93°C)	over 200°F (93°C)
Temperature	up to 200°F (93°C)	over 200°F (93°C)	up to 200°F (93°C)	over 200°F (93°C)	up to 200°F (93°C)	over 200°F (93°C)
Rotating face	Silicone carbide		Resin bonded carbon	Antimony loaded carbon	Resin bonded carbon	
Seat elastomer	EPDM (L-cup)	EPDM (O-ring)	EPDM (L-cup)	EPDM (O-ring)	EPDM (L-cup)	EPDM (O-ring)
Material code	SCSc L EPSS 2A	SCSc O EPSS 2A	C-SC L EPSS 2A	ACSc O EPSS 2A	C-SC L EPSS 2A	C-SC O EPSS 2A

MOTOR	HORSEPOWER @ RPM		MAX. DIMENSIONS INCHES (mm)											MAX. ASSEMBLY WEIGHT*			
	1800	1200	HA	HB	HC	HD	HE	HF	HG	HH	HL	X	Y	lbs	(kgs)		
FRAME	ODP/TEFC															ODP	TEFC
215TC	—	5	16.00 (406)	40.00 (1016)	36.35 (923)	13.00 (330)	7.38 (187)	36.00 (914)	3.00 (76)	0.75 (19)	6.50 (165)	14.00 (356)	6.00 (152)	419 (190.1)	485 (220.0)		
254TC	15	7.5	19.00 (483)	48.00 (1219)	45.52 (1156)	14.00 (356)	8.88 (225)	44.00 (1118)	4.00 (102)	0.75 (19)	6.50 (165)	14.00 (356)	6.00 (152)	617 (279.9)	651 (295.3)		
256TC	20	10	19.00 (483)	48.00 (1219)	45.52 (1156)	14.00 (356)	8.88 (225)	44.00 (1118)	4.00 (102)	0.75 (19)	6.50 (165)	14.00 (356)	6.00 (152)	660 (299.4)	684 (310.3)		
284TC	25	—	19.00 (483)	48.00 (1219)	48.64 (1235)	14.00 (356)	8.88 (225)	44.00 (1118)	4.00 (102)	0.75 (19)	6.50 (165)	14.00 (356)	6.00 (152)	738 (334.8)	841 (381.5)		
286TC	30	—	19.00 (483)	48.00 (1219)	48.64 (1235)	14.00 (356)	8.88 (225)	44.00 (1118)	4.00 (102)	0.75 (19)	6.50 (165)	14.00 (356)	6.00 (152)	790 (358.3)	885 (401.4)		
324TC	40	—	19.00 (483)	48.00 (1219)	51.65 (1312)	14.00 (356)	8.88 (225)	44.00 (1118)	4.00 (102)	0.75 (19)	6.50 (165)	14.00 (356)	6.00 (152)	935 (424.1)	1000 (453.6)		

*Assembly weight combines pump and motor.

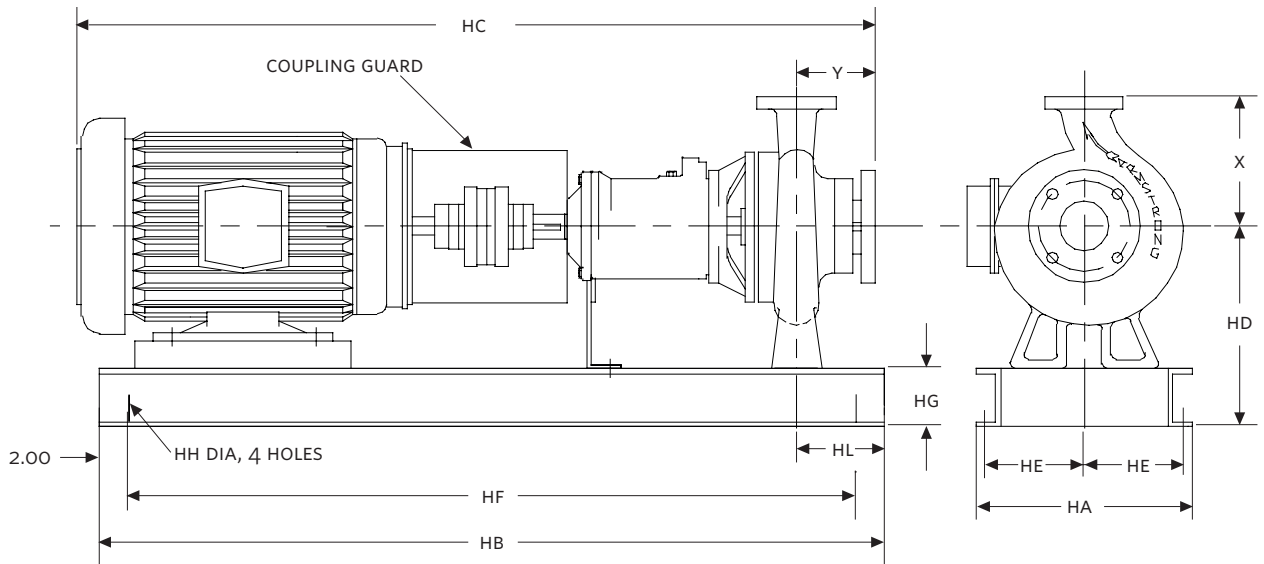

SERIES 4030 PERFORMANCE CURVES

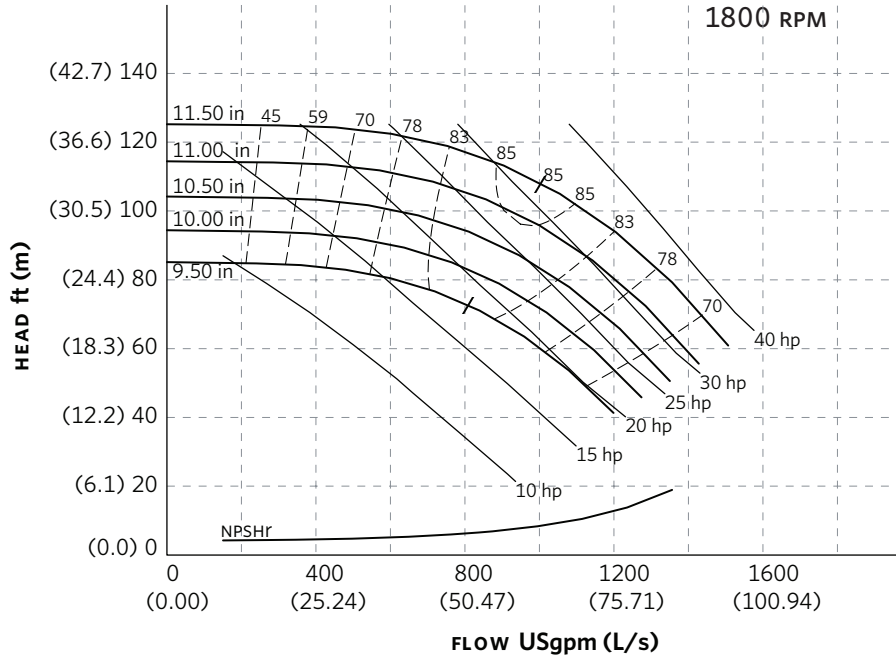

Curve number
PT102-1-0-1800

Series
4030
4280

Size
6 × 5 × 11.5

RPM
1800

BHP based on shown
Fluid's sp. gr.

Availability
4030 all ratings
4280 all ratings

Performance
guaranteed only
at operating point
indicated.
Curve shown for
clear, cold water
- SP. GR. 1.0000

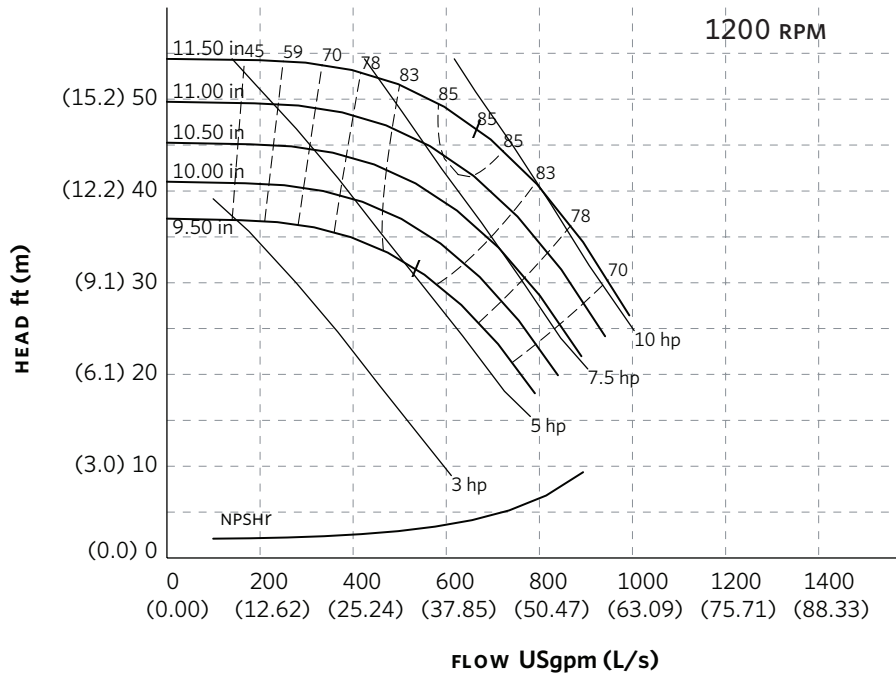

Curve number
PT102-1-0-1200

Series
4030
4280

Size
6 × 5 × 11.5

RPM
1200

BHP based on shown
Fluid's sp. gr.

Availability
4030 all ratings
4280 all ratings

Performance
guaranteed only
at operating point
indicated.
Curve shown for
clear, cold water
- SP. GR. 1.0000

Performance curves are for reference only.
Confirm current performance data with Armstrong ACE Online selection software.

TORONTO

23 BERTRAND AVENUE
TORONTO, ONTARIO
CANADA
M1L 2P3
+1 416 755 2291

BUFFALO

93 EAST AVENUE
NORTH TONAWANDA, NEW YORK
U.S.A.
14120-6594
+1 716 693 8813

BIRMINGHAM

HEYWOOD WHARF, MUCKLOW HILL
HALESOWEN, WEST MIDLANDS
UNITED KINGDOM
B62 8DJ
+44 (0) 8444 145 145

MANCHESTER

WENLOCK WAY
MANCHESTER
UNITED KINGDOM
M12 5JL
+44 (0) 8444 145 145

BANGALORE

#59, FIRST FLOOR, 3RD MAIN
MARGOSA ROAD, MALLESWARAM
BANGALORE, INDIA
560 003
+91 (0) 80 4906 3555

SHANGHAI

NO. 1619 HU HANG ROAD, XI DU TOWNSHIP
FENG XIAN DISTRICT, SHANGHAI
P.R.C.
201401
+86 21 3756 6696

**MAKING
ENERGY
MAKE
SENSE™**