

4030 END SUCTION BASE MOUNTED | 50-250A (3x2x10) | SUBMITTAL

File No: 40.62IEC
Date: AUGUST 10, 2020
Supersedes: 40.62IEC
Date: APRIL 26, 2016

Job: _____ Representative: _____
 _____ Order no.: _____ Date: _____
 Engineer: _____ Submitted by: _____ Date: _____
 Contractor: _____ Approved by: _____ Date: _____

PUMP DESIGN DATA

No. of pumps: _____ Tag: _____
 Capacity: _____ m³/h (USgpm) Head: _____ m(ft)
 Liquid: _____ Viscosity: _____
 Temperature: _____ °C (°F) Specific gravity: _____
 Suction: 75 mm (3") Flanged
 Discharge: 50 mm (2") Flanged

MATERIALS OF CONSTRUCTION

FLANGE RATING	PN 16	PN 25
Construction	<input type="checkbox"/> BF	<input type="checkbox"/> DBF
Casing	Cast iron	Ductile iron

- Impeller:** Bronze
- Gasket:** Confined non-asbestos fiber
- Bearing frame:** Cast iron
- Anti-friction bearings:** Permanently lubricated
- Shaft:** Carbon steel
- Shaft sleeve:** Stainless steel
- Coupler:** Woods sure flex or equal
- Coupler guard:** Steel OSHA
- Baseplate:** Fabricated steel

MECHANICAL SEAL DATA

- Seal type:** 2A **Stationary seat:** Silicone carbide
- Secondary seal:** EPDM **Rotating hardware:** Stainless steel
- Spring:** Stainless steel

MOTOR DESIGN DATA

kW: _____ RPM: _____
 Frame size: _____ Enclosure: _____
 Volts: _____ Hertz: 50 Hz Phase: 3
 Efficiency: IE1 IE2 IE3

MAXIMUM PUMP OPERATING CONDITIONS

- PN 16**
 16 bars at 49°C (232 psig at 120°F)
 7 bars at 150°C (100 psig at 300°F)
- PN 25**
 25 bars at 65°C (362 psig at 149°F)
 21 bars at 150°C (304 psig at 300°F)

- Tolerance of ±3 mm (±0.125") should be used
- For exact installation, data please write factory for certified dimensions
- Pump equipped with casing drain plug and ¼" NPT suction and discharge gauge ports.
- See performance curves on page 3

OPTIONAL EQUIPMENT

FLUID TYPE	ALL GLYCOLS > 30% WT CONC		ALL OTHER NON-POTABLE FLUIDS		POTABLE (DRINKING) WATER	
	up to 93°C (200°F)	over 93°C (200°F)	up to 93°C (200°F)	over 93°C (200°F)	up to 93°C (200°F)	over 93°C (200°F)
Rotating face	Silicone carbide		Resin bonded carbon	Antimony loaded carbon	Resin bonded carbon	
Seat elastomer	EPDM (L-cup)	EPDM (O-ring)	EPDM (L-cup)	EPDM (O-ring)	EPDM (L-cup)	EPDM (O-ring)
Material code	SCsc L EPSS 2A	SCsc O EPSS 2A	C-SC L EPSS 2A	ACsc O EPSS 2A	C-SC L EPSS 2A	C-SC O EPSS 2A

MOTOR	MOTOR kW @ RPM		FULL LOAD CURRENT (A)	STARTING CURRENT (A)		DIMENSIONS mm(INCHES)								WEIGHT*
	TEFC			STAR DELTA (SD)	DIRECT ON LINE (DOL)	HA	HB	HC	HD	HE	HF	HG	HL	kg (lbs)
	3000	1500												380-415V
90L	-	1.5	3.3	-	18.6	356 (14.00)	762 (30.00)	699 (27.54)	286 (11.25)	162 (6.38)	660 (26.00)	76 (3.00)	114 (4.50)	87.8 (194)
100L	-	2.2	4.82	-	26.5	356 (14.00)	838 (33.00)	741 (29.18)	286 (11.25)	162 (6.38)	737 (29.00)	76 (3.00)	114 (4.50)	96.3 (212)
100L	-	3	6.40	-	37.1	356 (14.00)	838 (33.00)	741 (29.18)	286 (11.25)	162 (6.38)	737 (29.00)	76 (3.00)	114 (4.50)	98.8 (218)
112M	-	4	8.41	18.5	58.9	356 (14.00)	838 (33.00)	785 (30.91)	286 (11.25)	162 (6.38)	737 (29.00)	76 (3.00)	114 (4.50)	107.8 (238)
132S	-	5.5	10.9	24.0	81.8	356 (14.00)	838 (33.00)	858 (33.78)	286 (11.25)	162 (6.38)	737 (29.00)	76 (3.00)	114 (4.50)	151.5 (334)
160M	11	-	21.1	52.8	164.6	406 (16.00)	1143 (45.00)	1084 (42.66)	286 (11.25)	187 (7.38)	1041 (41.00)	76 (3.00)	114 (4.50)	192.5 (424)
160M	15	-	28.5	74.1	228.0	406 (16.00)	1143 (45.00)	1084 (42.66)	286 (11.25)	187 (7.38)	1041 (41.00)	76 (3.00)	114 (4.50)	200.5 (442)
160L	18.5	-	34.9	94.2	303.6	406 (16.00)	1143 (45.00)	1099 (43.26)	286 (11.25)	187 (7.38)	1041 (41.00)	76 (3.00)	114 (4.50)	212.5 (468)
180M	22	-	40.9	114.5	368.1	483 (19.00)	1219 (48.00)	1084 (42.66)	311 (12.25)	225 (8.88)	1118 (44.00)	102 (4.00)	114 (4.50)	252.5 (557)
200L	30	-	55.9	139.8	436.0	483 (19.00)	1219 (48.00)	1261 (49.65)	352 (13.85)	225 (8.88)	1118 (44.00)	102 (4.00)	114 (4.50)	314.5 (693)
200L	37	-	68.7	171.8	535.9	483 (19.00)	1219 (48.00)	1261 (49.65)	352 (13.85)	225 (8.88)	1118 (44.00)	102 (4.00)	114 (4.50)	343.5 (757)

*Assembly weight combines pump and motor.

PUMP DIMENSIONS

mm (inches)

X	Y
241 (9.50)	102 (4.00)

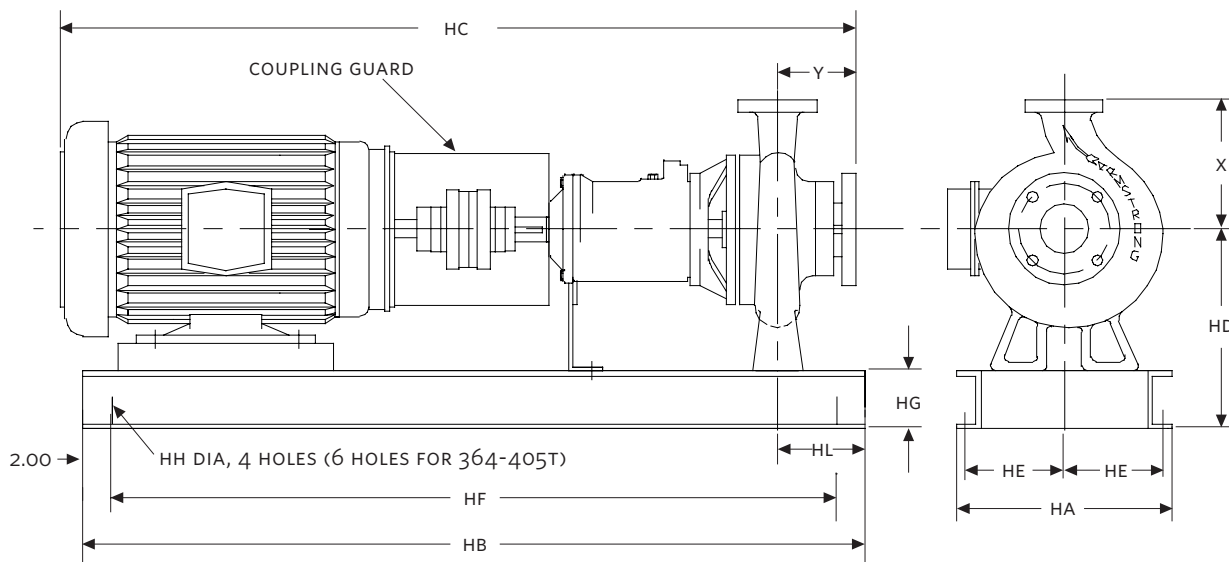

4030 PERFORMANCE CURVES

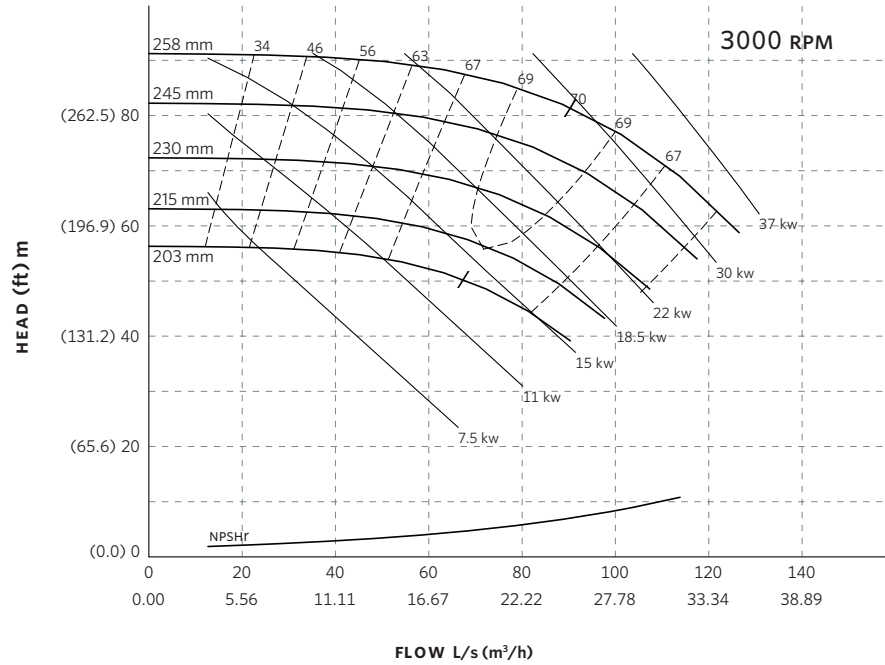

Curve number
PT59-2-0-3000

Series
4030
4280

Size
50-250A

RPM
3000

BHP based on shown
Fluid's sp. gr.

Availability
4030 all ratings
4280 all ratings

Performance
guaranteed only at
operating point
indicated.

Curve shown for
clear, cold water
- SP. GR. 1.000

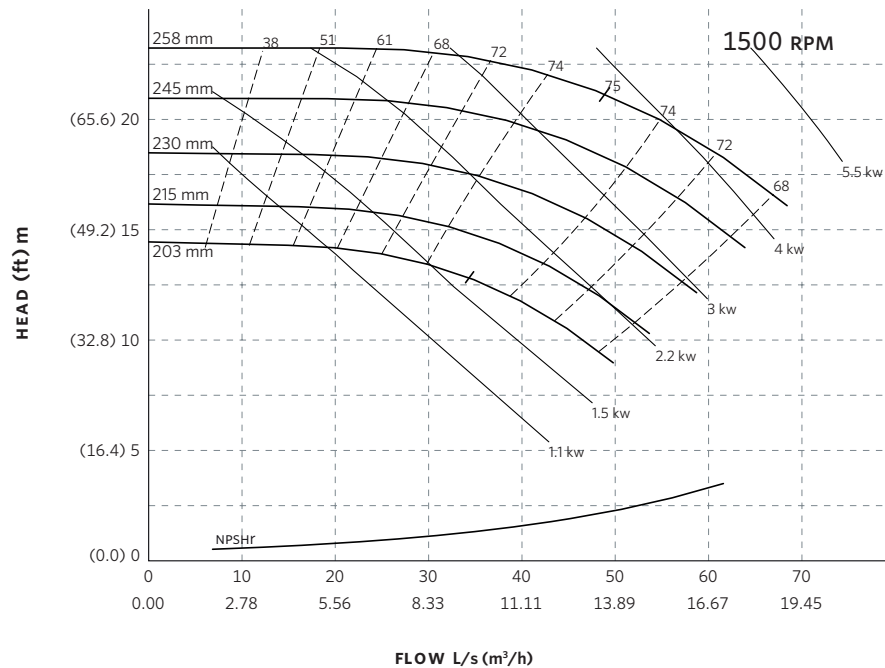

Curve number
PT58-2-0-1500

Series
4030
4280

Size
50-250A

RPM
1500

kwa based on shown
Fluid's sp. gr.

Availability
4030 all ratings
4280 all ratings

Performance
guaranteed only at
operating point
indicated.

Curve shown for
clear, cold water
- SP. GR. 1.000

Performance curves are for reference only.
Confirm current performance data with Armstrong ADEPT Quote or ADEPT Select selection software.

TORONTO

23 BERTRAND AVENUE
TORONTO, ONTARIO
CANADA, M1L 2P3
+1 416 755 2291

BUFFALO

93 EAST AVENUE
NORTH TONAWANDA, NEW YORK
U.S.A., 14120-6594
+1 716 693 8813

BIRMINGHAM

HEYWOOD WHARF, MUCKLOW HILL
HALESOWEN, WEST MIDLANDS
UNITED KINGDOM, B62 8DJ
+44 8444 145 145

MANCHESTER

WOLVERTON STREET
MANCHESTER
UNITED KINGDOM, M11 2ET
+44 8444 145 145

BANGALORE

#59, FIRST FLOOR, 3RD MAIN
MARGOSA ROAD, MALLESWARAM
BANGALORE, INDIA, 560 003
+91 80 4906 3555

SHANGHAI

UNIT 903, 888 NORTH SICHUAN RD.
HONGKOU DISTRICT, SHANGHAI
CHINA, 200085
+86 21 5237 0909

SÃO PAULO

RUA JOSÉ SEMIÃO RODRIGUES AGOSTINHO,
1370 GALPÃO 6 EMBU DAS ARTES
SAO PAULO, BRAZIL
+55 11 4785 1330

LYON

93 RUE DE LA VILLETTE
LYON, 69003 FRANCE
+33 4 26 83 78 74

DUBAI

JAFZA VIEW 19, OFFICE 402
P.O.BOX 18226 JAFZA,
DUBAI - UNITED ARAB EMIRATES
+971 4 887 6775

MANNHEIM

DYNAMOSTRASSE 13
68165 MANNHEIM
GERMANY
+49 621 3999 9858