

SERIES 4030 | END SUCTION BASE MOUNTED | 80-330A (4x3x13) | SUBMITTAL

File No: 40.74IEC
Date: APRIL 26, 2016
Supersedes: NEW
Date: NEW

Job: _____ Representative: _____
 _____ Order no.: _____ Date: _____
 Engineer: _____ Submitted by: _____ Date: _____
 Contractor: _____ Approved by: _____ Date: _____

PUMP DESIGN DATA

No. of pumps: _____ Tag: _____
 Capacity: _____ m³/h (USgpm) Head: _____ m(ft)
 Liquid: _____ Viscosity: _____
 Temperature: _____ °C (°F) Specific gravity: _____
 Suction: 100 mm (4") Flanged
 Discharge: 80 mm (3") Flanged

MATERIALS OF CONSTRUCTION

ANSI FLANGE RATING	PN 16	PN 25
Construction	<input type="checkbox"/> BF	<input type="checkbox"/> DBF
Casing	Cast iron	Ductile iron

- Impeller:** Bronze
- Gasket:** Confined non-asbestos fiber
- Bearing frame:** Cast iron
- Anti-friction bearings:** Permanently lubricated
- Shaft:** Carbon steel
- Shaft sleeve:** Stainless steel
- Coupler:** Woods sure flex or equal
- Coupler guard:** Steel OSHA
- Baseplate:** Fabricated steel

MECHANICAL SEAL DATA

- Seal type:** 2A **Stationary seat:** Silicone carbide
- Secondary seal:** EPDM **Rotating hardware:** Stainless steel
- Spring:** Stainless steel

MOTOR DESIGN DATA

kW: _____ RPM: _____
 Frame size: _____ Enclosure: _____
 Volts: _____ Hertz: 50 Hz Phase: 3
 Efficiency: IE1 IE2 IE3

MAXIMUM PUMP OPERATING CONDITIONS

- PN 16**
 12 bars at 65°C (175 psig at 150°F)
 10 bars at 121°C (140 psig at 250°F)
- PN 25**
 20 bars at 65°C (300 psig at 150°F)
 17 bars at 121°C (250 psig at 250°F)
- Tolerance of ±3 mm (±0.125") should be used
- For exact installation, data please write factory for certified dimensions
- Pump equipped with casing drain plug and ¼" NPT suction and discharge gauge ports.
- See performance curves on page 3

OPTIONAL EQUIPMENT

FLUID TYPE	ALL GLYCOLS > 30% WT CONC		ALL OTHER NON-POTABLE FLUIDS		POTABLE (DRINKING) WATER	
	up to 93°C (200°F)	over 93°C (200°F)	up to 93°C (200°F)	over 93°C (200°F)	up to 93°C (200°F)	over 93°C (200°F)
Rotating face	Silicone carbide		Resin bonded carbon	Antimony loaded carbon	Resin bonded carbon	
Seat elastomer	EPDM (L-cup)	EPDM (O-ring)	EPDM (L-cup)	EPDM (O-ring)	EPDM (L-cup)	EPDM (O-ring)
Material code	SCsc L EPSS 2A	SCsc O EPSS 2A	C-SC L EPSS 2A	ACsc O EPSS 2A	C-SC L EPSS 2A	C-SC O EPSS 2A

MOTOR	MOTOR kW @ RPM		FULL LOAD CURRENT (A)	STARTING CURRENT (A)		DIMENSIONS mm(INCHES)								WEIGHT*
	TEFC			STAR DELTA (SD)	DIRECT ON LINE (DOL)	HA	HB	HC	HD	HE	HF	HG	HL	
	3000	1500												
132S	—	5.5	10.9	24.0	81.8	406 (16.00)	1143 (45.00)	935 (36.82)	330 (13.00)	187 (7.38)	1041 (41.00)	76 (3.00)	114 (4.50)	203.6 (449)
132M	—	7.5	14.90	32.8	111.8	406 (16.00)	1143 (45.00)	958 (37.72)	330 (13.00)	187 (7.38)	1041 (41.00)	76 (3.00)	114 (4.50)	212.6 (469)
160M	—	11	21.90	50.4	168.6	406 (16.00)	1143 (45.00)	1082 (42.58)	330 (13.00)	187 (7.38)	1041 (41.00)	76 (3.00)	114 (4.50)	245.6 (541)
160L	—	15	29.60	68.1	227.9	406 (16.00)	1219 (48.00)	1097 (43.17)	356 (14.00)	225 (8.88)	1118 (44.00)	102 (4.00)	114 (4.50)	265.6 (586)
180M	—	18.5	36.3	94.4	304.9	406 (16.00)	1219 (48.00)	1082 (42.58)	356 (14.00)	225 (8.88)	1118 (44.00)	102 (4.00)	114 (4.50)	304.6 (672)

*Assembly weight combines pump and motor.

PUMP DIMENSIONS

mm (inches)

X	Y
318 (12.50)	102 (4.00)

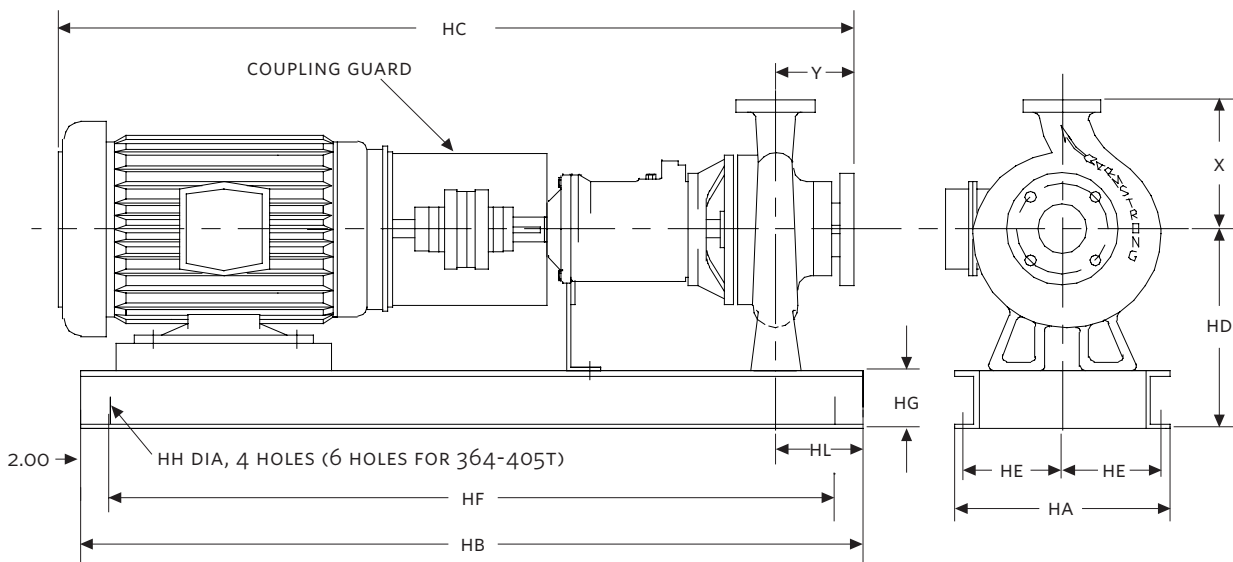

SERIES 4030 PERFORMANCE CURVES

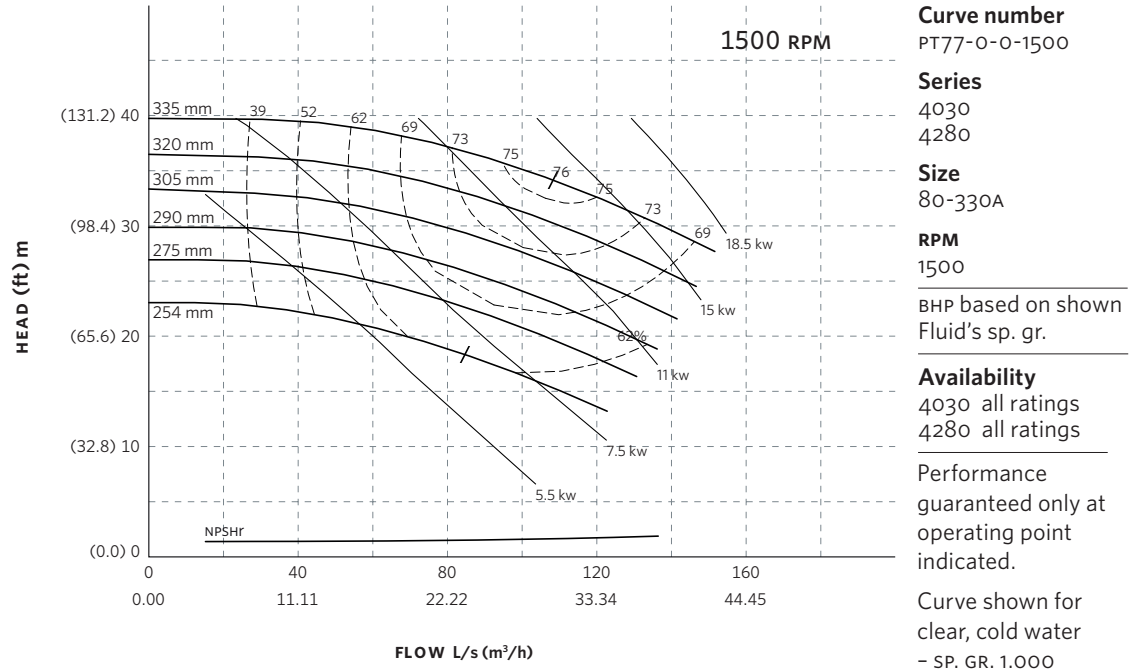

Performance curves are for reference only.
Confirm current performance data with Armstrong ACE Online selection software.

TORONTO

23 BERTRAND AVENUE
TORONTO, ONTARIO
CANADA
M1L 2P3
+1 416 755 2291

BUFFALO

93 EAST AVENUE
NORTH TONAWANDA, NEW YORK
U.S.A.
14120-6594
+1 716 693 8813

BIRMINGHAM

HEYWOOD WHARF, MUCKLOW HILL
HALESOWEN, WEST MIDLANDS
UNITED KINGDOM
B62 8DJ
+44 (0) 8444 145 145

MANCHESTER

WOLVERTON STREET
MANCHESTER
UNITED KINGDOM
M11 2ET
+44 (0) 8444 145 145

BANGALORE

#59, FIRST FLOOR, 3RD MAIN
MARGOSA ROAD, MALLESWARAM
BANGALORE, INDIA
560 003
+91 (0) 80 4906 3555

SHANGHAI

NO. 1619 HU HANG ROAD, XI DU TOWNSHIP
FENG XIAN DISTRICT, SHANGHAI
P.R.C.
201401
+86 21 3756 6696