

SERIES 4280 | END SUCTION BASE MOUNTED SPLIT COUPLED | 80-290A (4×3×11.5) | SUBMITTAL

File No: 42.75L
Date: MARCH 24, 2014
Supersedes: NEW
Date: NEW

Job: _____ Representative: _____

Order no.: _____ Date: _____

Engineer: _____ Submitted by: _____ Date: _____

Contractor: _____ Approved by: _____ Date: _____

PUMP DESIGN DATA

No. of pumps: _____ Tag: _____
Capacity: _____ m³/h (USgpm) Head: _____ m (ft)
Liquid: _____ Viscosity: _____
Temperature: _____ °C (°F) Specific gravity: _____
Suction: 100 mm (4") Flanged
Discharge: 75 mm (3") Flanged

MATERIALS OF CONSTRUCTION

FLANGE RATING	PN 16	PN 25
Construction	<input type="checkbox"/> BF	<input type="checkbox"/> DBF
Casing	Cast iron	Ductile iron
Adapter	Cast iron	Ductile iron

Impeller: Bronze

Gasket: Confined non-asbestos fiber

Bearing frame: Cast iron

Shaft: Carbon steel

Shaft sleeve: Bronze

MECHANICAL SEAL DATA

Seal type: 2A

Stationary seat: Silicone carbide

Secondary seal: EPDM

Rotating hardware: Stainless steel

Spring: Stainless steel

MOTOR DESIGN DATA

kW: _____ RPM: _____ Frame size: _____ Enclosure: _____
Volts: _____ Hertz: 50 Hz Phase: 3
Efficiency: IE1 (NON-EU only) IE2 IE3

MAXIMUM PUMP OPERATING CONDITIONS

PN 16

16 bars at 121°C (232 psig at 250°F)

PN 25

20 bars at 121°C (300 psig at 250°F)

- Tolerance of ±0.125" (±3 mm) should be used
- See performance curves on page 3
- For exact installation, data please write factory for certified dimensions
- Pump equipped with casing drain plug and ¼" NPT suction and discharge gauge ports

OPTIONAL EQUIPMENT

FLUID TYPE	ALL GLYCOLS > 30% WT CONC		ALL OTHER NON-POTABLE FLUIDS		POTABLE (DRINKING) WATER	
	up to 93°C (200°F)	over 93°C (200°F)	up to 93°C (200°F)	over 93°C (200°F)	up to 93°C (200°F)	over 93°C (200°F)
Temperature	up to 93°C (200°F)	over 93°C (200°F)	up to 93°C (200°F)	over 93°C (200°F)	up to 93°C (200°F)	over 93°C (200°F)
Rotating face	Silicone carbide		Resin bonded carbon	Antimony loaded carbon	Resin bonded carbon	
Seat elastomer	EPDM (L-cup)	EPDM (O-ring)	EPDM (L-cup)	EPDM (O-ring)	EPDM (L-cup)	EPDM (O-ring)
Material code	SCSC L EPSS 2A	SCSC O EPSS 2A	C-SC L EPSS 2A	ACSC O EPSS 2A	C-SC L EPSS 2A	C-SC O EPSS 2A

MOTOR	HORSEPOWER @ kW		FULL LOAD CURRENT (A)	STARTING CURRENT (A)		MAX. DIMENSIONS mm (INCHES)							MAX. ASSEMBLY WEIGHT*	
	3000	1500		STAR DELTA (SD)	DIRECT ON LINE (DOL)	A	B	C MAX	D1	D2	E	F	N	TEFC kgs (lbs)
132S	—	5.5	10.90	24.0	81.8	286 (11.26)	255 (10.04)	589 (23.21)	210 (8.25)	210 (8.25)	216 (8.50)	225 (8.86)	230 (9.05)	142.4 (314)
132M	—	7.5	14.90	32.8	111.8	286 (11.26)	255 (10.04)	612 (24.11)	210 (8.25)	210 (8.25)	216 (8.50)	225 (8.86)	268 (10.55)	151.4 (334)
160M	—	11	21.90	50.4	168.6	324 (12.76)	340 (13.39)	696 (27.41)	210 (8.25)	210 (8.25)	254 (10.00)	308 (12.13)	307 (12.10)	184.4 (406)
200L	37	—	68.7	171.8	535.9	418 (16.46)	425 (16.73)	940 (37.02)	260 (10.22)	260 (10.22)	318 (12.52)	393 (15.47)	360 (14.18)	334.4 (737)
225M	45	—	81.5	179.3	570.5	436 (17.17)	457 (17.99)	924 (36.39)	260 (10.22)	260 (10.22)	356 (14.02)	421 (16.57)	365 (14.38)	435.4 (960)

PUMP DIMENSIONS
mm (inches)

G	I	X
152 (6.00)	248 (9.76)	279 (11.00)

*Assembly weight combines pump and motor.

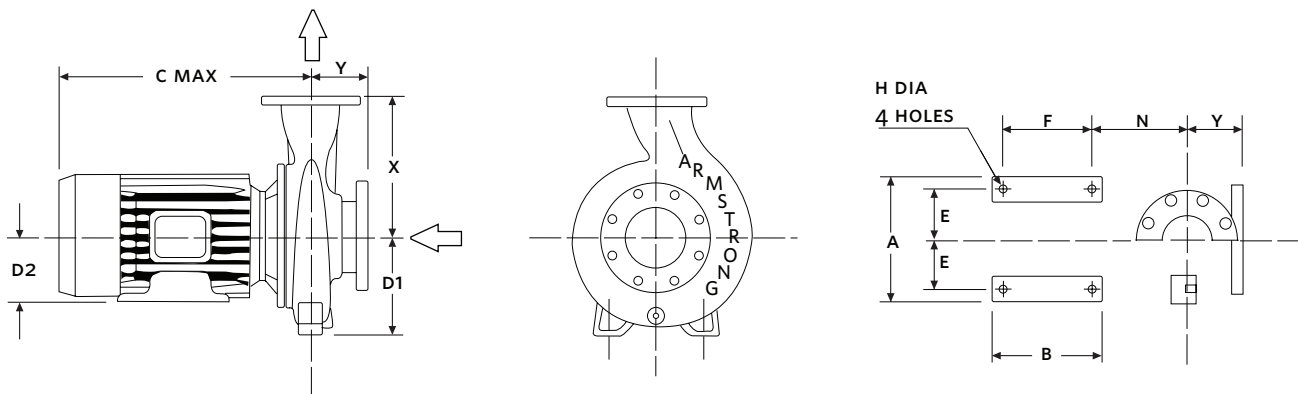

SERIES 4280 PERFORMANCE CURVES

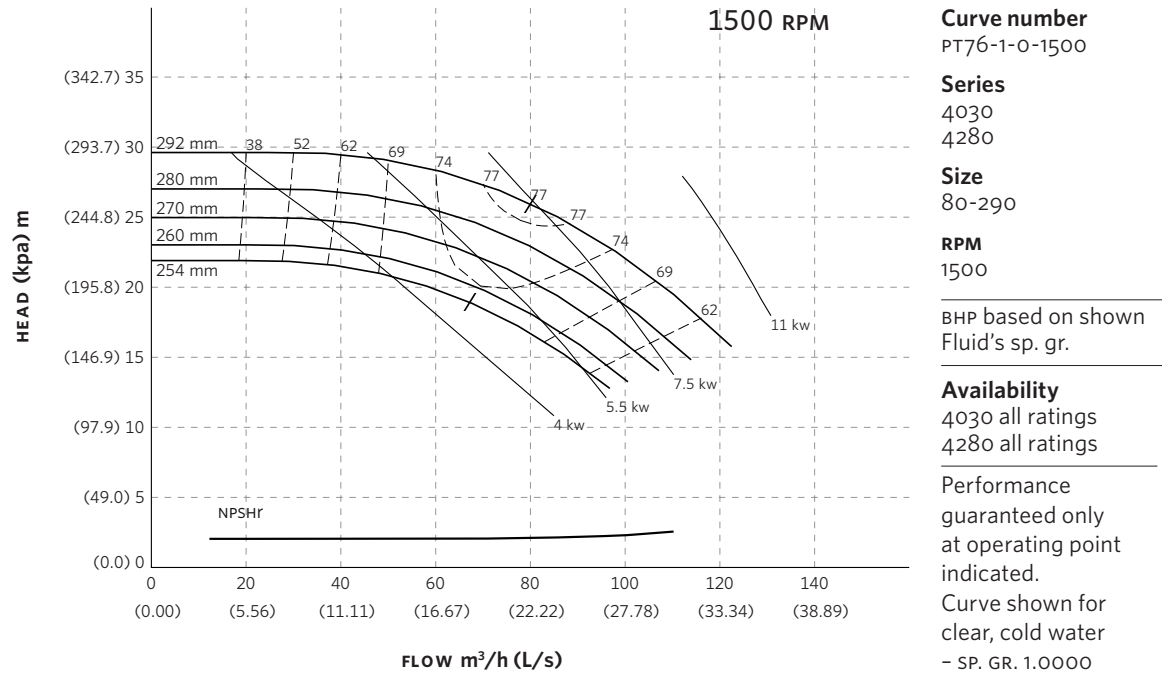

Performance curves are for reference only.
Confirm current performance data with Armstrong ACE Online selection software.

TORONTO

23 BERTRAND AVENUE
TORONTO, ONTARIO
CANADA
M1L 2P3
+1 416 755 2291

BUFFALO

93 EAST AVENUE
NORTH TONAWANDA, NEW YORK
U.S.A.
14120-6594
+1 716 693 8813

BIRMINGHAM

HEYWOOD WHARF, MUCKLOW HILL
HALESOWEN, WEST MIDLANDS
UNITED KINGDOM
B62 8DJ
+44 (0) 8444 145 145

MANCHESTER

WENLOCK WAY
MANCHESTER
UNITED KINGDOM
M12 5JL
+44 (0) 8444 145 145

BANGALORE

#59, FIRST FLOOR, 3RD MAIN
MARGOSA ROAD, MALLESWARAM
BANGALORE, INDIA
560 003
+91 (0) 80 4906 3555

SHANGHAI

NO. 1619 HU HANG ROAD, XI DU TOWNSHIP
FENG XIAN DISTRICT, SHANGHAI
P.R.C.
201401
+86 21 3756 6696

**MAKING
ENERGY
MAKE
SENSE™**