

DESIGN ENVELOPE 4200H END SUCTION

40-125 (2x1.5x5) | 4012-007.5 | SUBMITTAL

File No: 103.5417IEC
 Date: MARCH 25, 2021
 Supersedes: 103.5417IEC
 Date: SEPTEMBER 5, 2019

Job: _____ Representative: _____
 _____ Order No: _____ Date: _____
 Engineer: _____ Submitted by: _____ Date: _____
 Contractor: _____ Approved by: _____ Date: _____

PUMP DESIGN DATA

No. of pumps: _____ Tag: _____
 Capacity: _____ L/s (USgpm) Head: _____ m (ft)
 Liquid: _____ Viscosity: _____
 Temperature: _____ °C (°F) Specific gravity: _____
 Suction: 50 mm (2") Discharge: 40 mm (1.5")
 MEI ≥ 0.70

MATERIALS OF CONSTRUCTION

- PN 16**
 CONSTRUCTION: LPDESF
 E-coated ductile iron A536 Gr 65-45-12, stainless fitted
- PN 25**
 CONSTRUCTION: HPDESF
 E-coated ductile iron A536 Gr 120-90-2, stainless fitted

MAXIMUM PUMP OPERATING CONDITIONS

- PN 16**
 16 bar at 49°C (232 psig at 120°F)
 7 bar at 150°C (100 psig at 300°F)
- PN 25**
 25 bar at 65°C (362 psig at 149°F)
 21 bar at 150°C (304 psig at 300°F)

MECHANICAL SEAL DESIGN DATA

See file no. 43.50 for standard mechanical seal details as indicated below
 Armstrong seal reference number
 c1 (a) Others: _____

FLOW READOUT ACCURACY

The Design Envelope model selected will provide flow reading on the controls local keypad & digitally for the BMS. The model readout will be factory tested to ensure ±5% accuracy.

DEPM MOTOR AND CONTROL DATA

kW: 7.5
RPM: 3000
Motor enclosure: TEFC
Volts: _____
Phase: 3
Efficiency: IE5
Orientation: L5 (default) L6
Protocol (standard): BACnet™ MS/TP
 BACnet™ TCP/IP
 Modbus RTU
Control enclosure: Indoor - IP 55
Fused disconnect switch: Consult factory
EMI/RFI control: Integrated filter designed to meet EN61800-3
Harmonic suppression: Equivalent: 5% AC line reactor - Supporting IEEE 519-1992 requirements**
Cooling: Fan-cooled, surface cooling
Ambient temperature: -10°C to +45°C up to 1000 meters above sea level (+14°F to +113°F, 3300 ft)
Analog I/O: Two inputs, one output. Output can be configured for voltage or current
Digital I/O: Two inputs, two outputs. Outputs can be configured as inputs
Relay outputs: Two programmable
Communication port: 1-RS485

** If supplied with the system electrical details, Armstrong will run a computer simulation of the system wide harmonics. If system harmonic levels are exceeded Armstrong can also recommend additional harmonic mitigation and the costs for such mitigation.

OPTIONS

SENSORLESS BUNDLE (STANDARD)



Operation of pump without a remote sensor. Includes:

- Sensorless control
- Flow readout
- Constant flow
- Constant pressure

Minimum system pressure to be maintained _____ m (ft)

* If minimum maintained system pressure is not known:
Default to 40% of design head

PARALLEL SENSORLESS



Operation of multiple pumps without a remote sensor

Minimum system pressure to be maintained _____ m (ft)

* If minimum maintained system pressure is not known:
Default to 40% of design head

ENERGY PERFORMANCE BUNDLE



Provides energy savings on oversized systems by adjusting pump parameters to on-site conditions. Includes:

- **Auto-flow balancing** - Automatically determines control curve between design flow at on-site system head, and minimum (zero-head) flow for energy savings
- **Maximum flow control** - Limits flow rate to pre-set maximum for potential energy savings

Maximum flow rate _____ L/s (gpm)

*Only available if sensorless bundle is enabled
*Available in single pump operation only

PROTECTION BUNDLE



Protects other flow sensitive equipment by setting limits of pump operation. Includes:

- **Minimum flow control** - Attempts to maintain flow rate to pre-set minimum to protect equipment in system
- **Bypass valve control** - Actuates a bypass valve to protect flow sensitive equipment if pre-set minimum flow rate is reached

Minimum flow rate _____ L/s (gpm)

*Only available if sensorless bundle is enabled

DUAL SEASON SETUP



Pre-sets heating and cooling parameters for pumps in 2-pipe systems

Cooling

Duty point _____ L/s (gpm) at _____ m (ft)

Minimum system pressure to be maintained _____ m (ft)

Heating

Duty point _____ L/s (gpm) at _____ m (ft)

Minimum system pressure to be maintained _____ m (ft)

*Available in single pump operation only

OPTIONAL SERVICES

ON-SITE PUMP COMMISSIONING



PUMP MANAGER



Online service for sustained pump performance and enhanced reliability.

Available in 3 or 5 year terms

* Requires an internet connection to be provided by building

* Includes an extended warranty for parts and labour (wearable parts excluded)

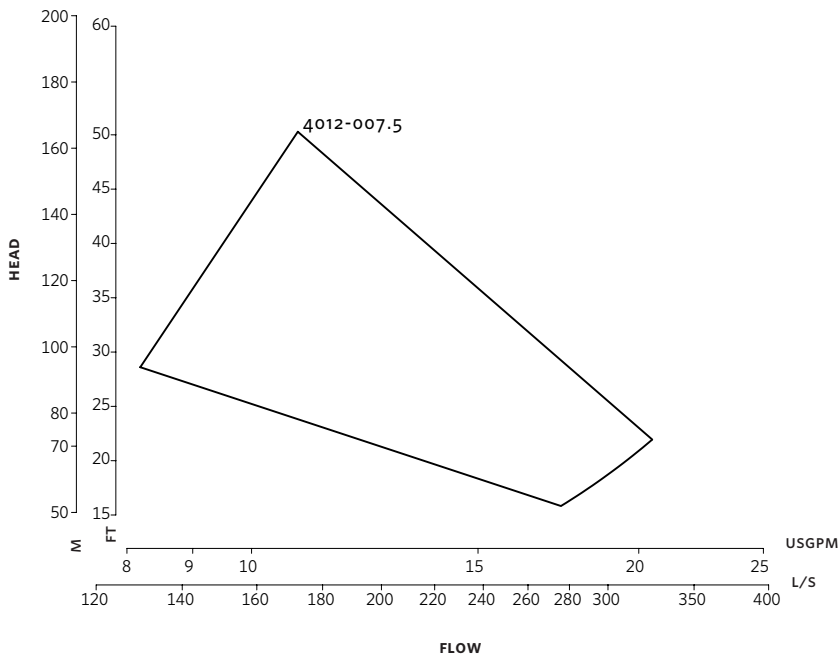

DIMENSION DATA

STANDARD

Size:	2×1.5×5
κW:	7.5
RPM:	3000
HA:	338 (13.31)
HD:	222 (8.75)
HI:	618 (24.35)
HV:	259 (10.18)
X:	178 (7.00)
Y:	102 (4.00)
Free & operating height:	95 (3.75)
Weight:	50.0 (110)

SPRING DATA

Rated Capacity per spring	kgs (lbs): 113.0 (51)
Rated Deflection	mm (inch): 25 (1.00)
Mount Constant	kg/mm (lbs/in): 2.0 (113)

SEISMIC MOUNT OPTION

2E:	267 (10.50)
F:	102 (4.00)
G:	152 (6.00)
H:	12 (0.50)
HA:	324 (12.75)
HD:	254 (10.00)
N:	252 (9.91)
Free & operating height:	127 (5.00)
Max. horizontal static G rating:	3.2

Performance curves are for reference only.

Confirm current performance data with Armstrong ADEPT Quote or ADEPT Select selection software.

STANDARD

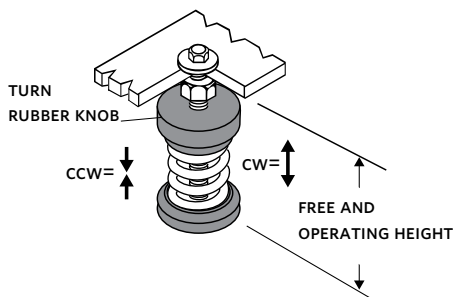

SEISMIC MOUNT OPTION

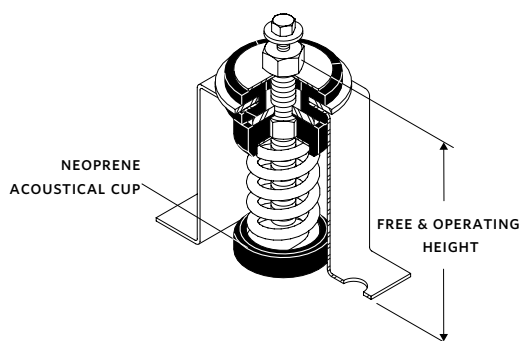

NOTE:

All springs have additional travel to solid equal to 50% of the rated deflection.

- Dimensions - mm (inch)
- Weight - kg (lbs)

- Tolerance of ±3 mm (±0.125") should be used
- For exact installation, data please write factory for certified dimensions

STANDARD

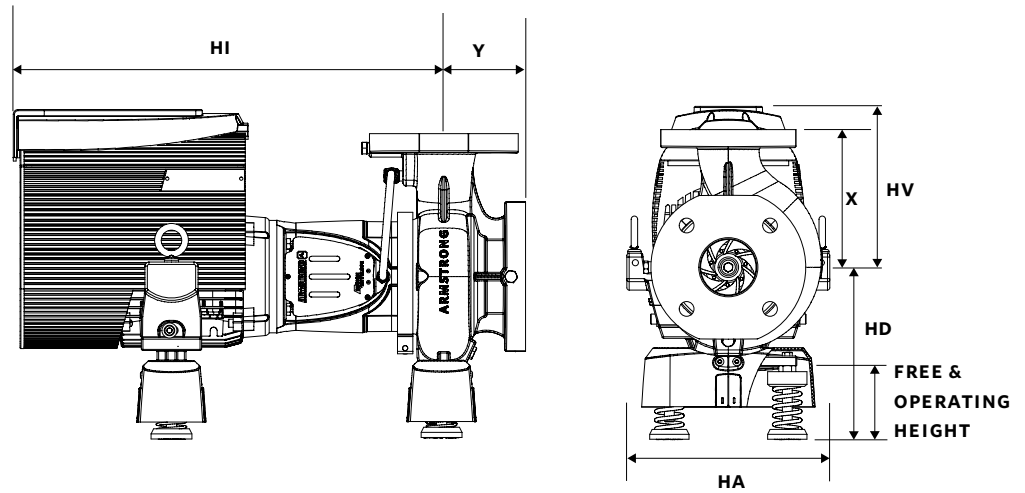

SEISMIC MOUNT OPTION

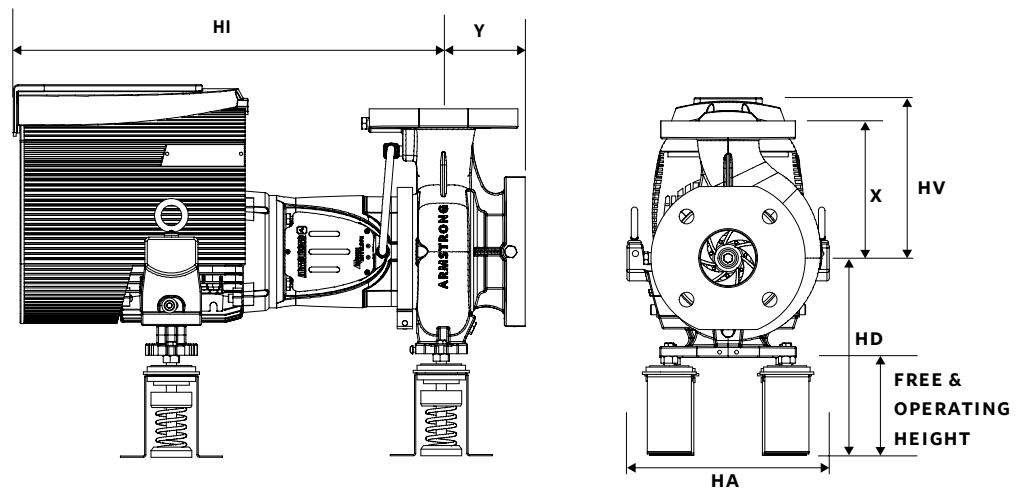

TORONTO
+1 416 755 2291

BUFFALO
+1 716 693 8813

BIRMINGHAM
+44 (0) 8444 145 145

MANCHESTER
+44 (0) 8444 145 145

BANGALORE
+91 (0) 80 4906 3555

SHANGHAI
+86 (0) 21 5237 0909

SÃO PAULO
+55 11 4785 1330

LYON
+33 (0) 420 102 625

DUBAI
+971 4 887 6775

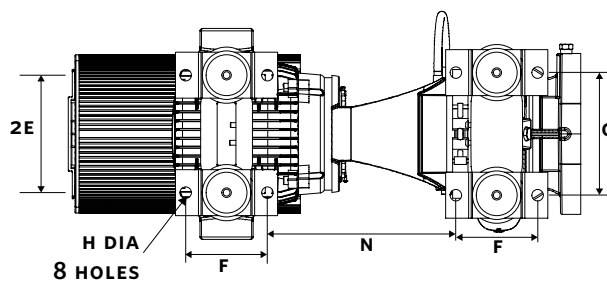

MANNHEIM
+49 (0) 621 3999 9858