

## DESIGN ENVELOPE 4302 DUALARM | 0408-005.0 | SUBMITTAL

File No: 100.4454  
 Date: OCTOBER 30, 2015  
 Supersedes: 100.4448  
 Date: AUGUST 14, 2015

Job: \_\_\_\_\_ Representative: \_\_\_\_\_  
 \_\_\_\_\_ Order No: \_\_\_\_\_ Date: \_\_\_\_\_  
 Engineer: \_\_\_\_\_ Submitted by: \_\_\_\_\_ Date: \_\_\_\_\_  
 Contractor: \_\_\_\_\_ Approved by: \_\_\_\_\_ Date: \_\_\_\_\_

### PUMP DESIGN DATA

No. of pumps: \_\_\_\_\_ Tag: \_\_\_\_\_  
 Capacity: \_\_\_\_\_ USgpm (L/s) Head: \_\_\_\_\_ ft (m)  
 Liquid: \_\_\_\_\_ Viscosity: \_\_\_\_\_  
 Temperature: \_\_\_\_\_ °F (°C) Specific gravity: \_\_\_\_\_  
 Suction: 4" (100mm) Discharge: 4" (100mm)

**OSHPD Seismic Certification OSP-0422-10**  
**UL STD 778 & CSA STD C22.2 NO.108 certified**

### MOTOR DESIGN DATA

HP: \_\_\_\_\_ RPM: \_\_\_\_\_ Frame size: \_\_\_\_\_ Enclosure: \_\_\_\_\_  
 Volts: \_\_\_\_\_ Hertz: 60 Hz Phase: 3  
 Efficiency: NEMA premium 12.12

### MAXIMUM PUMP OPERATING CONDITIONS

#### ANSI 125

175 psig at 150°F (12 bars at 65°C)  
 140 psig at 250°F (10 bars at 121°C)

#### ANSI 250

250 psig at 150°F (17 bars at 65°C)  
 250 psig at 250°F (17 bars at 121°C)

- Tolerance of ±0.125" (±3 mm) should be used
- For exact installation, data please write factory for certified dimensions

### MECHANICAL SEAL DESIGN DATA

See file no. 43.50 for standard mechanical seal details as indicated below

Armstrong seal reference number

c1 (a)  Others: \_\_\_\_\_

### CONTROLS DATA

**Sensorless Control:** Standard

**Minimum system pressure to be maintained:** \_\_\_\_\_ ft (m)\*

**Protocol (standard):**  Modbus RTU  BACnet™ MS/TP  
 Johnson® N2  Siemens® FLN

**Protocol (optional):**  LonWorks®

**Enclosure:**  Indoor - UL TYPE 12  
 Outdoor - UL TYPE 4X with Weather Shield  
 Outdoor - UL TYPE 4X less Weather Shield

**Fused disconnect switch:**

**Duty/standby pre-wired bridge:**

**EMI/RFI control:** Integrated filter designed to meet EN61800-3

**Harmonic suppression:** Dual dc-link reactors (Equivalent: 5% AC line reactor) Supporting IEEE 519-1992 requirements\*\*

**Cooling:** Fan-cooled through back channel

**Ambient temperature:** -10°C to +45°C up to 1000 meters above sea level (-14°F to +113°F, 3300 ft)

**Analog I/O:** Two current or voltage inputs, one current output

**Digital I/O:** Six programmable inputs (two can be configured as outputs)

**Pulse inputs:** Two programmable

**Relay outputs:** Two programmable

**Communication port:** 1-RS485, 1-USB

\*If minimum maintained system pressure is not known: Default to 40% of design head

\*\*The IVS 102 drive is a low harmonic drive via built-in dc line reactors. This does not guaranty performance to any system wide harmonic specification or the costs to meet a system wide specification. If supplied with the system electrical details, Armstrong will run a computer simulation of the system wide harmonics. If system harmonic levels are exceeded Armstrong can also recommend additional harmonic mitigation and the costs for such mitigation.

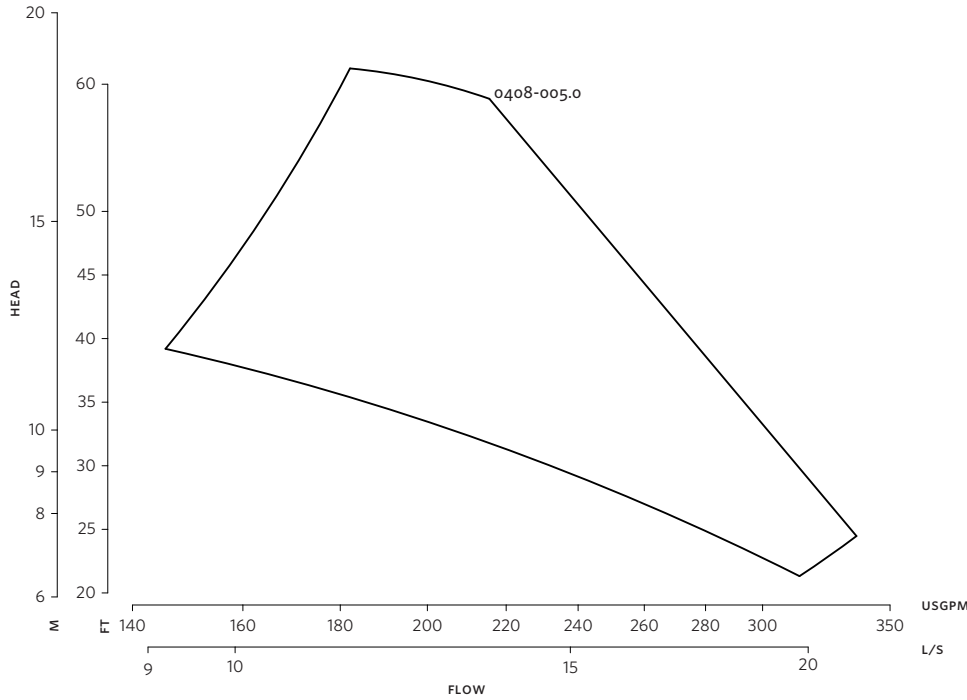

**DIMENSION DATA**

	INDOOR (UL TYPE 12/ODP)	OUTDOOR (UL TYPE 4X/TEFC)
<b>Frame size:</b>	184	184
<b>Size:</b>	4×4×8	4×4×8
<b>HP:</b>	5	5
<b>RPM:</b>	1800	1800
<b>AB:</b>	27.55(700)	33.51(851)
<b>B1:</b>	8.75(222)	8.75(222)
<b>B2:</b>	8.75(222)	8.75(222)
<b>C1:</b>	15.09(383)	15.09(383)
<b>C2:</b>	15.63(397)	15.63(397)
<b>D1:</b>	14.84(377)	14.84(377)
<b>D2:</b>	14.84(377)	14.84(377)
<b>E:</b>	6.84(174)	7.50(191)
<b>P:</b>	10.38(264)	9.56(243)
<b>F:</b>	13.65(347)	19.50(495)
<b>SD:</b>	27.63(702)	27.63(702)
<b>T:</b>	6.28(160)	6.28(160)
<b>XY:</b>	26.54(674)	26.42(671)
<b>Weight:</b>	612(277.6)	668(303.0)

Performance curves are for reference only.  
Confirm current performance data with Armstrong ACE Online selection software.

Dimensions - inch (mm)  
Weight - lbs (kg)

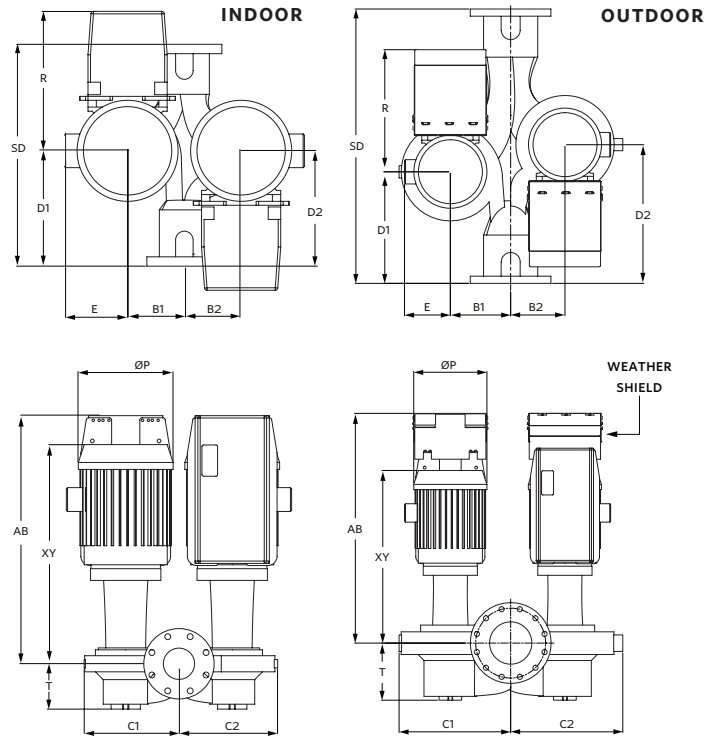

**TORONTO**  
+1 416 755 2291

**BUFFALO**  
+1 716 693 8813

**BIRMINGHAM**  
+44 (0) 8444 145 145

**MANCHESTER**  
+44 (0) 8444 145 145

**BANGALORE**  
+91 (0) 80 4906 3555

**SHANGHAI**  
+86 21 3756 6696