

HORIZONTAL SPLIT CASE PUMP | SERIES 4600F |
DIESEL DRIVEN | 8x6x15NF/MF/HF | SUBMITTAL

File No: F46.560
Date: SEPTEMBER 25, 2018
Supersedes: F46.560
Date: AUGUST 10, 2016

Job: _____ Representative: _____
_____ Order no.: _____ Date: _____
Engineer: _____ Submitted by: _____ Date: _____
Contractor: _____ Approved by: _____ Date: _____

PUMP DESIGN DATA

Flow: _____
Head: _____

ENGINE DESIGN DATA

HP: _____ RPM: _____
Bat. Voltage: _____ Tank size: _____
Other: _____

NOTES

- 1 Std. Discharge flange thickness ANSI 250#.
- 2 Coupling guard not shown.
- 3 All dimensions for engine connections are with reference to engine manufacturer's installation drawings.
- 4 Do not use for construction unless certified.
- 5 Right hand rotation only.

FLANGE RATING

- ANSI 125# STD¹
- ANSI 125# Suction
250# Discharge
- ANSI 250#
- PN 16

FIRE PUMP LISTING

- UL
- ULC
- FM

ACCESSORIES

- Exhaust system
- Fuel system
- Cooling system (mounted on engine)
- Battery system

8x6x15NF/ MF/HF	HORIZONTAL SPLIT CASE DIESEL DRIVEN	DIMENSIONS inches (mm)							WEIGHT lbs (kg)
		C	HA	HB	HE	HF	HM	Z	
Clarke	JU4H series	86.02 (2185)	32.00 (813)	82.00 (2083)	30.00 (762)	39.00 (991)	58.42 (1484)	18.00 (457)	2192 (994.5)
	JU6H series	96.10 (2441)	32.00 (813)	95.00 (2413)	30.00 (762)	45.50 (1156)	58.70 (1491)	18.00 (457)	3024 (1371.7)
	JW6H series	102.40 (2601)	32.00 (813)	100.00 (2540)	30.00 (762)	32.00 (813)	64.60 (1641)	21.67 (550)	3409 (1546.5)
Cummins	CFP33 series	76.13 (1934)	32.00 (813)	82.00 (2083)	30.00 (762)	39.00 (991)	41.66 (1058)	17.13 (435)	1998 (906.3)
	CFP59 series	87.45 (2221)	32.00 (813)	95.00 (2413)	30.00 (762)	45.50 (1156)	47.44 (1205)	18.00 (457)	2712 (1230.2)
	CFP83 series	95.55 (2427)	32.00 (813)	100.00 (2540)	30.00 (762)	32.00 (813)	49.02 (1245)	18.00 (457)	3090 (1401.7)
	CFP5E series	85.99 (2184)	32.00 (813)	95.00 (2413)	30.00 (762)	45.50 (1156)	47.53 (1207)	18.00 (457)	2597 (1177.8)
	CFP7E series	96.94 (2462)	32.00 (813)	100.00 (2540)	30.00 (762)	32.00 (813)	47.53 (1207)	18.00 (457)	2775 (1258.8)
	CFP9E series	98.73 (2508)	32.00 (813)	100.00 (2540)	30.00 (762)	32.00 (813)	49.63 (1261)	18.00 (457)	3195 (1449.3)

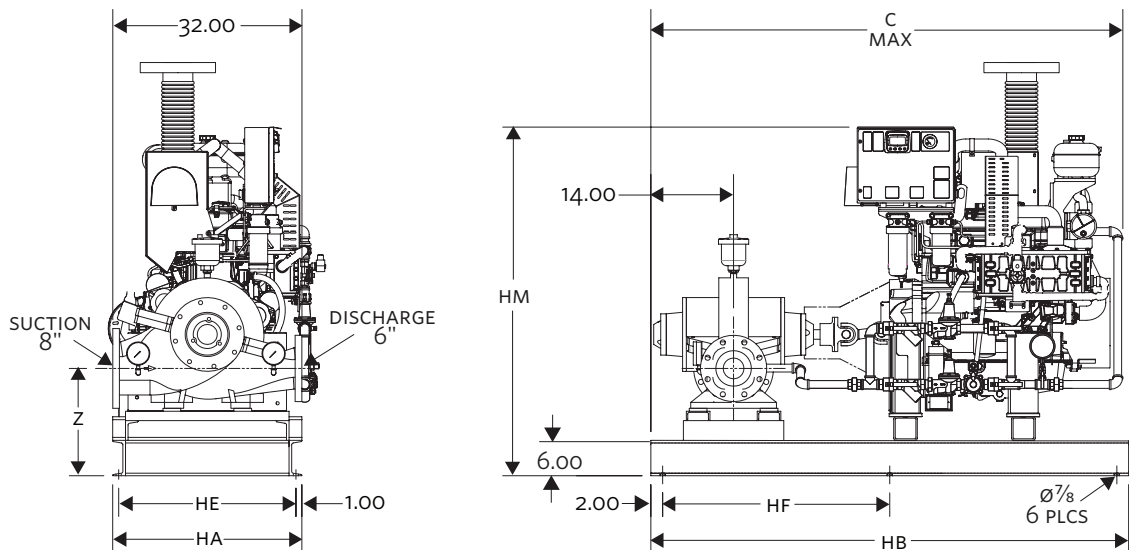

TORONTO
+1 416 755 2291

BUFFALO
+1 716 693 8813

BIRMINGHAM
+44 (0) 8444 145 145

MANCHESTER
+44 (0) 8444 145 145

BANGALORE
+91 (0) 80 4906 3555

SHANGHAI
+86 21 3756 6696

SÃO PAULO
+55 11 4785 1330